

Építőanyag

A Szilikátipari Tudományos Egyesület lapja

Journal of Silicate Based and Composite Materials

A TARTALOMBÓL:

- Porosity and Mechanical Properties of Zirconium Ceramics
- The Influence of Temperature on the Properties of ZrW_2O_8
- Foam Glass Ceramics as Composite Granulated Heat-Insulating Material
- The Influence of Porosity on the Elasticity and Strength of Alumina Ceramics
- Restructuring of Ceramics Features with Changes in the Large and Nanocrystalline Ceramic System Ratio
- Optimization of ceramic manufacturing process using Plackett-Burman design of experiment

2014/2



University
of Miskolc



NATIONAL RESEARCH
Tomsk State University

We are pleased to announce the organization of

ic-cmtp3

THE 3rd INTERNATIONAL CONFERENCE ON COMPETITIVE MATERIALS AND TECHNOLOGY PROCESSES

to be held at Hunguest Hotel Palota Lillafüred in Miskolc, Hungary, October 6-10, 2014.

The 2nd International Conference on Competitive Materials and Technology Processes was also held in this wonderful palace hotel in the exceptionally beautiful Bükk Mountains and together with coauthors have participated on it more than 550 scientists from 36 countries of Asia, Europe, America and Africa.

The peer reviewed and accepted papers of **ic-cmtp3** conference will be published in periodicals of IOP Conference Series: Materials Science and Engineering (MSE) which are referred by Scopus, EI Compendex, Inspec, INIS, Chemical Abstracts, NASA Astrophysics Data System and many others. As organizers we hope you will submit your abstract and will attend on **ic-cmtp3** conference and we are looking forward to welcome you in **Miskolc, Hungary in October 6-10, 2014.**

The objectives

The event based more to academia than to industry and all papers will be peer reviewed before publication in **IOP Conference Series Materials Sciences and Engineering**, which is refereed by SCOPUS and many others. The international conference **ic-cmtp3** provides a platform among leading international scientists, researchers, engineers, students and PhD students for discussing recent achievements in research and development of material structures and properties of competitive materials like nanomaterials, ceramics, glasses, films and coatings, metals, alloys, biomaterials, composites, hetero-modulus and hybrid-materials, ... etc.

Among the major fields of interest are materials with extreme physical, chemical, thermal, mechanical properties and dynamic strengths; including their crystalline and nano-structures, phase-transformations as well as methods of their technological processes, tests and measurements.

Promote new methods and results of scientific researches and multidisciplinary applications of material science and technological problems encountered in sectors like ceramics, glasses, metal alloys, thin films, aerospace, automotive and marine industry, electronics, energy, security, safety and construction materials, chemistry, medicine, cosmetics, biosciences, environmental sciences are of particular interests.

Sessions

Session 1: Advanced Materials for Bio- and Medical Applications
Session 2: Advanced Materials for Extreme Applications
Session 3: Advanced Nanomaterials with Predesigned Properties
Session 4: Biomaterial Derived Ceramics and Composites
Session 5: Glasses, Coatings and Related Materials
Session 6: Hetero-Modulus, Hetero-Viscous and Hybrid Materials
Session 7: Light-Weight Metals and Alloys
Session 8: Materials with Extreme Dynamic Strength for Safety and Security

Session 9: Membranes and Catalysts
Session 10: Minerals for Environmental and Medical Applications
Session 11: Nanomaterials for Environment and Health
Session 12: Novel Synthesis and Processing Technology
Session 13: Phase Diagram as a Tool of Materials Science
Session 14: Polymer Derived Ceramics
Session 15: Processing and Properties of Silicate Ceramics
Session 16: Refractory and Fireproof Materials

The peer reviewed and accepted papers of **ic-cmtp3** conference will be published in periodicals of IOP Conference Series: Materials Science and Engineering (MSE) which are referred by Scopus, EI Compendex, Inspec, INIS, Chemical Abstracts, NASA Astrophysics Data System and many others.

The organizers hope that you will attend on **ic-cmtp3** conference and can welcome you in **Miskolc, Hungary in October 6-10, 2014.**

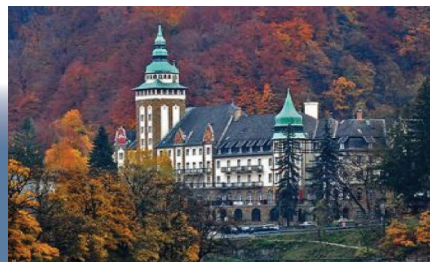

TARTALOM

- 31** Porózus cirkon-oxid kerámiák és mechanikai tulajdonságuk
Ekaterina KALATUR ■ Svetlana BUYAKOVA ■ Sergey N. KULKOV ■ Irene GOTMAN ■ KOCSERHA István
- 35** A hőmérséklet hatása a ZrW_2O_8 kerámiák tulajdonságaira
Sergey N. KULKOV ■ Elena S. DEDOVA ■ Fernando PEDRAZA ■ ERDÉLYI János
- 38** Habosított üveg-kerámia granulátumok, mint hőszigetelő kompozit anyagok
Afanasy S. APKARYAN ■ Sergey N. KULKOV ■ GÖMZE A. László
- 44** A porozitás hatása alumínium-oxid kerámiák szilárdságára és rugalmasságára
Nikolai L. SAVCHENKO ■ Irina N. SEVOSTYANOVA ■ Tatiana Yu. SABLINA ■ MOLNÁR Lucia ■ GÉBER Róbert ■ GÖMZE A. László ■ Sergey N. KULKOV ■ GÖMZE N. Ludmila
- 48** Szerkezet-átalakulások és viselkedésbeli változások a nagy- és nanokristályos kerámia rendszerekben
Mihail GRIGORIEV ■ GÖMZE A. László ■ Sergey N. KULKOV
- 52** Kerámia gyártási folyamat optimalizálása a Plackett-Burman kísérlettervezési módszer alkalmazásával
EGÉSZ Ádám ■ Svetlana P. BUYAKOVA ■ Sergey N. KULKOV ■ GÖMZE A. László

CONTENT

- 31** Porosity and Mechanical Properties of Zirconium Ceramics
Ekaterina KALATUR ■ Svetlana BUYAKOVA ■ Sergey N. KULKOV ■ Irene GOTMAN ■ István KOCSERHA
- 35** The Influence of Temperature on the Properties of ZrW_2O_8
Sergey N. KULKOV ■ Elena S. DEDOVA ■ Fernando PEDRAZA ■ János ERDÉLYI
- 38** Foam Glass Ceramics as Composite Granulated Heat-Insulating Material
Afanasy S. APKARYAN ■ Sergey N. KULKOV ■ László A. GÖMZE
- 44** The Influence of Porosity on the Elasticity and Strength of Alumina Ceramics
Nikolai L. SAVCHENKO ■ Irina N. SEVOSTYANOVA ■ Tatiana Yu. SABLINA ■ Lucia MOLNÁR ■ Róbert GÉBER ■ László A. GÖMZE ■ Sergey N. KULKOV ■ Ludmila N. GÖMZE
- 48** Restructuring of Ceramics Features with Changes in the Large and Nanocrystalline Ceramic System Ratio
Mihail GRIGORIEV ■ László A. GÖMZE ■ Sergey N. KULKOV
- 52** Optimization of ceramic manufacturing process using Plackett-Burman design of experiment
Ádám EGÉSZ ■ Svetlana P. BUYAKOVA ■ Sergey N. KULKOV ■ László A. GÖMZE

A finomkerámia-, üveg-, cement-, mész-, beton-, téglá- és cserép-, kő- és kavics-, tűzállóanyag-, szigetelőanyag-iparágak szakmai lapja
Scientific journal of ceramics, glass, cement, concrete, clay products, stone and gravel, insulating and fireproof materials and composites

SZERKESZTŐBIZOTTSÁG • EDITORIAL BOARD

Prof. Dr. GÖMZE A. László – elnök/president
Dr. BOROSNYÓI Adorján – főszerkesztő/editor-in-chief
WOJNÁROVITSNÉ Dr. HRAPKA Ilona – örökös
tiszteltetbeli felelős szerkesztő/senior editor-in-chief
TÓTH-ASZTALOS Réka – tervezőszerkesztő/design editor

TAGOK • MEMBERS

Prof. Dr. Parvin ALIZADEH, BOCSKAY Balázs,
Prof. Dr. CSÖKE Barnabás, Prof. Dr. Katherine T. FABER,
Prof. Dr. Saverio FIORE, Prof. Dr. David HUI,
Prof. Dr. GÁLOS Miklós, Dr. Viktor GRIBNIAK,
Prof. Dr. Kozo ISHIZAKI, Dr. JÓZSA Zsuzsanna,
KÁRPÁTI László, Dr. KOCSERHA István,
Dr. KOVÁCS Kristóf, Prof. Dr. Sergey N. KULKOV,
MATTYASOVSKY ZSOLNAY Eszter, Dr. MUCSI Gábor,
Prof. Dr. OPOCZKY Ludmilla, Dr. PÁLVÖLGYI Tamás,
Dr. RÉVAY Miklós, Prof. Dr. Tomasz SADOWSKI,
Prof. Dr. Tohru SEKINO, Prof. Dr. David S. SMITH,
Prof. Dr. Bojja SREEDHAR, Prof. Dr. SZÉPVÖLGYI János,
Prof. Dr. SZÜCS István, Prof. Dr. TAMÁS Ferenc

TANÁCSADÓ TESTÜLET • ADVISORY BOARD

FINTA Ferenc, KISS Róbert, Dr. MIZSER János

A folyóiratot referálja:
Cambridge Scientific Abstracts



A folyóiratban lektorált cikkek jelennek meg.
Kiadja a Szilikátipari Tudományos Egyesület
1034 Budapest, Bécsi út 122-124.
Telefon és fax: +36-1/201-9360
E-mail: epitoanyag@szte.org.hu
Felelős kiadó: ASZTALOS István SZTE ELNÖK
Tördelőszerkesztő: NÉMETH Hajnalka

Címlapfotó/Cover photo by KÓSA Luca Kornélia

Belföldi terjesztés: SZTE
Külföldi terjesztés: BATHYANY KULTUR-PRESS KFT.

HIRDETÉSI ÁRAK 2014 / ADVERTISING RATES 2014:

B2 borító színes / cover colour	76 000 Ft	304 EUR
B3 borító színes / cover colour	70 000 Ft	280 EUR
B4 borító színes / cover colour	85 000 Ft	340 EUR
1/1 oldal színes / page colour	64 000 Ft	256 EUR
1/1 oldal fekete-fehér / page b&w	32 000 Ft	128 EUR
1/2 oldal színes / page colour	32 000 Ft	128 EUR
1/2 oldal fekete-fehér / page b&w	16 000 Ft	64 EUR
1/4 oldal színes / page colour	16 000 Ft	64 EUR
1/4 oldal fekete-fehér / page b&w	8 000 Ft	32 EUR

Az árak az áfát nem tartalmazzák. / Without VAT.
A hirdetési megrendelő letölthető a folyóirat honlapjáról.
Order-form for advertisement is available on the website of the journal.

WWW.EPITOANYAG.ORG.HU

Online ISSN: 2064-4477 ■ Print ISSN: 0013-970X
INDEX: 2 52 50 ■ 66 (2014) 29-56

A SZILIKÁTIPIARI TUDOMÁNYOS EGYESÜLET

TÁMOGATÓ TAGVÁLLALATI

3B Hungária Kft. ■ Air Liquide Kft. ■ Anzo Kft.
Baranya Téglá Kft. ■ Berényi Téglaiipari Kft.
Budai Téglá Zrt. ■ Budapest Kerámia Kft.
Cerlux Kft. ■ Colas-Északkő Kft. ■ Electro-Coord Kft.
Fátyolüveg Kft. ■ G&B Elastomer Kft. ■ GE Hungary Zrt.
Geoteam Kft. ■ Guardian Orosháza Kft. ■ Hunext Kft.
Interkerám Kft. ■ KK Kavics Beton Kft. ■ KÓKA Kft.
Kötés Kft. ■ KTI Kft. ■ Kvarc-Ásvány Kft.
Lambda Systeme Kft. ■ Libál Lajos ■ Lighttech Kft.
Maltha Hungary Kft. ■ Messer Hungarogáz Kft.
MFL Hungária Kft. ■ Mineralholding Kft.
MTA KK AKI O-I Manufacturing Magyarország Kft.
OMYA Kft. ■ Pápateszéri Tégl. Kft. ■ Perlit-92 Kft. ■ Q&L Kft.
RATH Hungária Kft. ■ Rockwool Hungary Kft.
Speciál Bau Kft. ■ Szema Makó Kft. ■ SZIKKTI Labor Kft.
WITEG Kőporc Kft. ■ Zalakerámia Zrt.

Preface

Several years ago, we have realized that existing opportunities in communication and networking of the international scientific community were no longer adequate and even insufficient. Given such a global vision, we could take decisions for ourselves and with a view to the needs of his own surroundings with reasonable certainty that they were compatible and effective in reaching objectives and valid values for oneself and at the same time in keeping with a shared own context that could eventually be globally extended and realized together. Therefore we have signed multilayer Agreement between Miskolc University, Tomsk State University and Institute of Strength Physics and Material Sciences SB RAS.

In accordance with a mutual wish to promote international scientific and technological exchange, Tomsk State University, Institute of Strength Physics and Material Sciences SB RAS and Miskolc University join in an agreement in order to further promote mutual cooperation in education and scientific research. Within fields that are mutually acceptable, the following general forms of cooperation were pursued: exchange of undergraduate and/or graduate students; exchange of faculty members and/or research scholars; joint research activities in nanomaterials, nanotechnology, living systems areas; exchange of scientific materials and information. The program was co-ordinated by Prof. Dr. S. Kulkov for TSU and ISPMS RAS for the Russian part and by Prof. Dr. L. Gömze for the Hungarian part.

The present issue of *Építőanyag* – Journal of Silicate Based and Composite Materials, therefore, is a special issue that includes several papers on ceramic materials for different applications which were prepared by both Russian and Hungarian sides.

Several interesting topics were included in this issue.

Designing and developing highly-effective materials that remain stable under extreme conditions are among the primary tasks of modern materials science. One potential solution for this challenge lies in the development of composite materials with appropriate matrix and filler. The use of ceramics as matrix is reasonable as ceramics possess high mechanical strength, hardness and wear resistance while retaining their properties under high temperatures. However, ceramics are known to display low toughness making them brittle enough for specific applications. Therefore, the introduction of internal stresses at the filler/matrix interface allows strengthening of the overall composite structure. Such internal stresses can be introduced through a filler that has negative thermal expansion behavior due to the opposite

thermal expansion values of the source filler and matrix materials.

A promising method for creating permeable ceramic materials with high porosity is the mixing large-fractured and ultrafine powders, and the geometry of the pores obtained in such a way is determined by the size and shape of large-fractured powder particles. Porous ceramic materials have been successfully used in various fields, including heat-insulating building materials, since they are durable, corrosion resistant and possess stable thermal features. The combination of these characteristics is especially important for construction in seismic regions.

Ceramics based on partially stabilized zirconium are the most interesting materials among the variety of ceramics due to their inherent high fracture toughness, as a result of their inherent transformational conversion. It is known that the characteristics are determined by the quality of the source ceramic powder (particle shape, particle size distribution), the conditions of compacting and sintering modes and any features that are presented in each phase, and how these phases, including pores, are arranged in relation to each other. The most important factor in the successful application of materials understands the features of a structure emerging in them on their behavior under mechanical impact.

It is well known that the porosity of brittle materials can have significant influence on their physical (mechanical, thermal, electrical) properties. Young's modulus, shear modulus and Poisson's ratio are essential parameters in the studies of advanced material mechanics. In addition, the macroscopic behavior of ceramics can vary from brittle to quasi-plastic, depending on the pore space volume. That is why the investigation of the evolution of deterioration in a brittle porous material at different levels of scale and the subsequent damage depending on the deformation rate, constraint, etc. is of considerable interest in terms of the emergence of a structural hierarchy of deformation and destruction in similar brittle materials (ceramics, natural stones etc.).

*Prof. László Gömze
Prof. Sergey Kulkov
Dr. Adorján Borosnyói*



Porosity and Mechanical Properties of Zirconium Ceramics

EKATERINA KALATUR ▪ Tomsk State University, Institute of Strength Physics and Materials Science SB RAS Tomsk Polytechnic University ▪ kalatures@mail.ru

SVETLANA BUYAKOVA ▪ Tomsk State University, Institute of Strength Physics and Materials Science SB RAS Tomsk Polytechnic University ▪ sbuyakova@ispms.tsc.ru

SERGEY N. KULKOV ▪ Tomsk State University, Institute of Strength Physics and Materials Science SB RAS Tomsk Polytechnic University ▪ kulkov@ispms.tsc.ru

IRENE GOTMAN ▪ Technion - Israel Institute of Technology, Haifa, Israel ▪ gotman@tx.technion.ac.il

ISTVÁN KOCSERHA ▪ University of Miskolc, Dep. of Ceramics and Silicate Engineering at Institute of Ceramics and Polymer Engineering ▪ fempityu@uni-miskolc.hu

Received: 02. 06. 2014. ▪ Érkezett: 2014. 06. 02. ▪ <http://dx.doi.org/10.14382/epitoanyag-jsbcm.2014.6>

Abstract

Porous ceramics have been studied obtained from ultra-fine ZrO_2 powders. The porosity of ceramic samples was from 15 to 80%. The structure of the ceramic materials was a cellular structure. A distinctive feature of all the deformation diagrams obtained in the experiment was their nonlinearity at low deformations which was described by the parabolic law. It was shown that the observed nonlinear elasticity for low deformations on deformation diagrams is due to mechanical instability of the cellular elements in the ceramic carcass.

Keywords: zirconium oxide ceramics; plasma chemistry method; porosity; particle size distribution; mechanical properties

1. Introduction

Porous ceramic materials have been successfully used in various fields, including heat-insulating building materials, because they are durable, corrosion resistant and they possess stable thermal features [1-3]. The combination of these characteristics is especially important for construction in seismic regions.

Ceramics based on partially stabilized zirconium are the most interesting among the variety of ceramic materials [4-6] due to their inherent high fracture toughness that is attributed to their inherent transformational conversion. It is known that the characteristics are determined by the quality of source ceramic powder (particle shape, particle size distribution) [7, 8], the conditions of compacting and sintering modes [9, 10] and any features that are presented in each phase, and how these phases, including pores, are arranged in relation to each other [11]. The most important factor in the successful application of materials is the understanding of the features of a structure emerging in them on their behavior under mechanical impact [12].

The aim of the paper is to examine the effect of $ZrO_2(Me_xO_y)$ pore structure of ceramics on features their deformation behaviour and mechanical properties.

2. Materials and experimental procedure

The materials for the study were ceramics obtained from powders of $ZrO_2(MgO)$, $ZrO_2(Y_2O_3)$, liquid-phase decomposition of precursors synthesized in high-frequency discharge plasma (plasma chemistry method). Porous ceramic $ZrO_2(MgO)$, $ZrO_2(Y_2O_3)$ powder was prepared by pressing and subsequent sintering of compacts at homologous temperatures ranging from 0.63 to 0.56 during the isothermal holding duration of 1 to 5 hours. The porosity of ceramics $ZrO_2(MgO)$, $ZrO_2(Y_2O_3)$ ranged from 15 to $\approx 45\%$ and ≈ 30 to 80%, respectively. X-ray studies were carried out on a diffractometer

Dr. Ekaterina S. KALATUR

Dr. Kalatur graduated at the Tomsk State University in 2010. She has got scientific degree "Candidate of Technical Sciences" at Institute of Strength Physics and Materials Science SB RAS in 2013. Topic of her Ph.D. work was "Influence of porosity on structural - phase state, deformation and fracture of porous ceramics" under guidance of Prof. Buyakova. Dr.Kalatur is author or co-author of 25 articles and 1 Russian patent.

Prof. Svetlana P. Buyakova

Doctor of Sciences from 2008, full Professor from 2013. She is specialist in material sciences of ceramic and ceramic matrix composites based on oxides and carbides. She is author and co-author of more than 100 papers. Four persons (three Ph.D. students) finished their dissertations under her guidance in the period 2010-2013. Now, she is chief scientist in IS PMS RAS and professor in Tomsk State University and Tomsk Polytechnic University. Her teaching experience: Introduction to materials science, Fundamentals of materials engineering, Materials and their applications.

Prof. Sergey N. Kulkov

Prof. Kulkov is head of Department of Ceramics in the Institute of Strength Physics and Materials Science of the Russian Academy of Science since 1989. He has got scientific degrees „Doctor of Physics and Mathematical Sciences” in 1990. Since 1992 he's working as professor both in Tomsk State University and in Tomsk Polytechnic University. In 1997 he had a Soros Professor grant. His research works are represented in 5 books, more than 150 articles, 18 patents and many International Symposiums and Conferences. At present he is head of department „Theory of Strength and Mechanic of Solids”, member of „The American Ceramic Society” of „The APMI - International” and the DYM AT Society (France).

Dr. Irene Gotman

After receiving her doctorate, Dr. Gotman spent three years as a Fulbright Post-doctoral Fellow at Drexel University, Philadelphia. In 1995, she returned to the Department of Materials Science & Engineering at Technion as a Levi Eshkol Post-doctoral Fellow. From 2001, Dr. Gotman is a Senior Research and Teaching Fellow. She is a member of European Society for Biomaterials (ESB). She is also active in the field of reactive synthesis and was awarded, in 2007, a Diploma and a Jubilee Medal for contribution to R&D by Scientific Center of Russian Academy of Sciences and International Association of Self-Propagating High-Temperature Synthesis (World Academy of Ceramics).

Dr. István Kocserha

Finishing his MSc study as a mechanical engineer Dr. Kocserha has continued his studies as Ph.D. student under supervision of Prof. Dr. László A. Gömze at the Department of Ceramic and Silicate Engineering (DCSE) in University of Miskolc (Hungary) in 1999. The scope of his PhD thesis was "The effects of additives on the extrusion of brick clay compounds". Since 1999 he was involved into 68 research projects in the DCSE which were financed by different multinational companies or government. Dr. Kocserha is author or co-author of 32 articles and 1 Hungarian patent. At present he works at the Department of Ceramic and Silicate Engineering in University of Miskolc as assistant professor.

with filtered $CuK\alpha$ radiation. Studies on the ceramic structure were carried out by scanning electron microscope (SEM) Philips SEM 515. Mechanical tests on samples of porous ceramics were carried out by INSTRON-1185 universal testing device at a constant rate of loading $4 \cdot 10^{-4} \text{ s}^{-1}$ in uniaxial compression.

3. Results and discussion

3.1 Powders

Fig. 1 represents the SEM-picture of ZrO_2 powder (3 mol.% Y_2O_3), synthesized by the method of plasma chemistry and

particle size distribution of the powder size. ZrO_2 powders (3 mol.% MgO) and ZrO_2 (3 mol.% Y_2O_3) practically have no difference in morphological structure and they consist of hollow particles of a spherical shape and a large number of units having no regular form. The average particle size of the spherical powders ZrO_2 (MgO), ZrO_2 (Y_2O_3) was 1.8 and 1.5 microns, respectively.

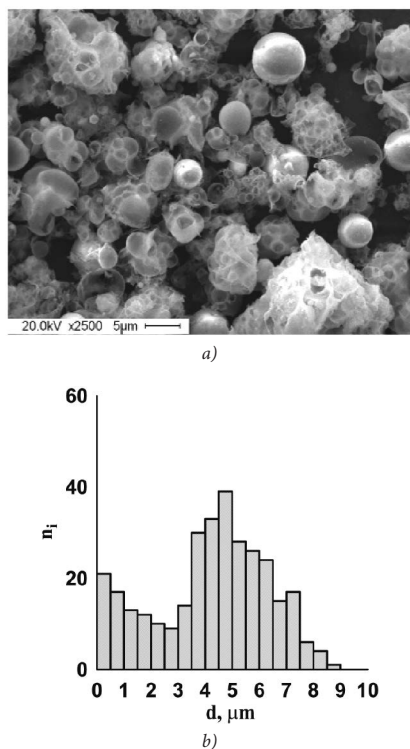

Fig. 1. SEM - picture of ZrO_2 powder (Y_2O_3), synthesized by the method of plasma chemistry (a) and particle size distribution of ZrO_2 powder (Y_2O_3) size (b).
1. ábra Plazma-kémiai módszerrel előállított (Y_2O_3) stabilizált ZrO_2 por SEM-képe (a) és szemcseméret-eloszlása (b)

The phase composition of ZrO_2 powder (Y_2O_3) is presented by tetragonal and monoclinic ZrO_2 . In the powder ZrO_2 (MgO) the cubic, tetragonal and monoclinic phases of ZrO_2 were present. The ratio of tetragonal ZrO_2 powder ZrO_2 (Y_2O_3) was about 95%, and ZrO_2 in the cubic phase ZrO_2 powder (MgO) – 75%. The average size of the coherent scattering regions (SCR) tetragonal ZrO_2 in ZrO_2 powder (Y_2O_3) was 20 nm, and the monoclinic modification – 50 nm. The average size of cubic modification SCR of ZrO_2 in ZrO_2 powder (MgO) was 20 nm, monoclinic ZrO_2 – 30 nm, in the tetragonal phase – 15 nm.

3.2 Sintered ceramics

Fig. 2 represents the SEM-picture of ZrO_2 ceramics structure (Y_2O_3) and pore size distribution. ZrO_2 ceramics structure (MgO), ZrO_2 (Y_2O_3) were represented as a cellular frame. Cells had a nearly spherical shape. The cell size exceeded by many times the thickness of the walls, which was represented as a single ZrO_2 layer stacking grain.

Pore size distribution was bimodal. The first maximum pore was formed by interparticle pores that were not filled with powder particles during compaction and the second - with the larger pores close to a spherical shape. From the data

presented in Fig. 2.b dependences of interparticles pores and larger spherical pores from porosity in ceramics ZrO_2 (MgO), ZrO_2 (Y_2O_3), it is seen that the increase in the volume of pores in the material from ≈ 30 to 80% was achieved by reducing the sintering temperature of the samples and it was accompanied by an increase in the average size of large pores from 2 to 6 microns. Changing the porosity of the material had practically no influence on the average size of interparticle pores, the average size of which was 0.5 microns. It can be assumed that the presence of large pores close to a spherical shape in the ceramics is due to the presence of hollow spherical particles in source powders, since their average size is commensurate with an average size of presented large pores in the sintered material.

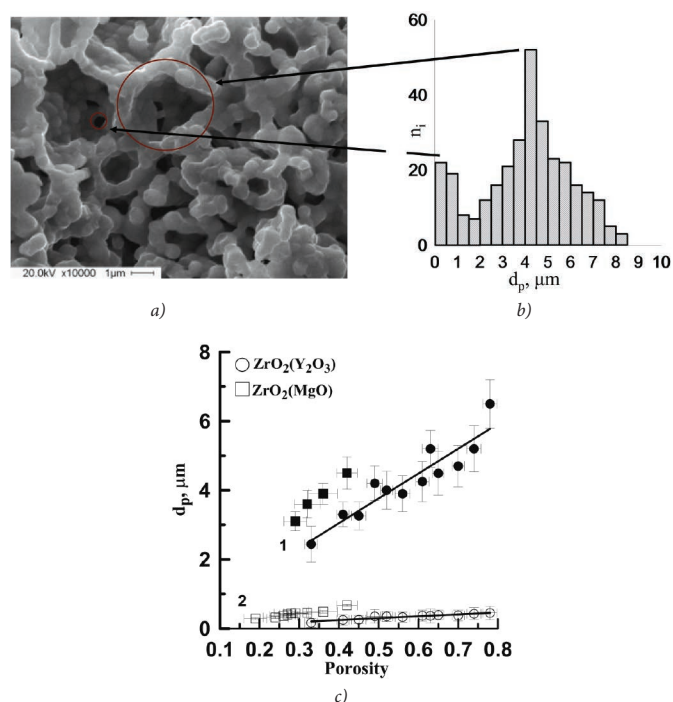

Notations for part c) / Jelmagyarázat a c) ábra részhez:
1) the average size of large pores close to a spherical shape; a gömbszerű nagy pórusok átlagmérete;
2) the average size of interparticle pores; a szemcseközi pórusok átlagmérete.
Fig. 2. SEM-Picture of ZrO_2 ceramics structure (Y_2O_3), the characteristic pore size distribution of ZrO_2 ceramics (MgO) with a porosity of $\approx 40\%$ (a) and the dependence of the average pore size on the porosity of ZrO_2 (MgO) and ZrO_2 (Y_2O_3) ceramics (b) – as well as average pore sizes as function of porosity (c).
2. ábra A közel 40% pórustérfogatú ZrO_2 (Y_2O_3) és ZrO_2 (MgO) kerámiák SEM-felvétele (a) és pórus-szerkezete (b) – valamint ezek átlagos pórusátmérője mint a porozitás függvénye (c).

Fig. 3.a shows the deformation diagram during the compression loading of ZrO_2 ceramic samples (Y_2O_3), ZrO_2 (MgO) having a porosity more than 30%. For these ZrO_2 ceramics samples (Y_2O_3), ZrO_2 (MgO) it is characteristic a bimodal pore distribution. Ascending branches of the deformation diagrams of porous ceramics (stage active deformation) can be characterized by two distinctive features: I – Nonlinear behaviour to the strain ϵ_1 , II – the presence of vertical sections of the reset stress associated with the advent of micro-material. The appearance of the first micro-damages in the material was recorded as the first vertical portion stress reset σ_d . Despite the appearing of separate

material damage which had a local character, the macro-value of loaded sample generally retained the ability to resist the increasing load until the stress value σ_{max} , which corresponds to the limiting strain ϵ_{max} .

Such a σ - ϵ type of the diagrams is also characteristic for materials that have a core or cellular structure. The authors of the study [13] have shown that during the compression loading of ZrO_2 porous ceramics, the structure of which is represented as a ceramic frame consisting of randomly oriented rod elements, there is a reversible loss of mechanical stability of the core elements (micromechanical instability [14]), which leads to the emergence of the nonlinear coupling between stress and strain in the elastic deformation of the material.

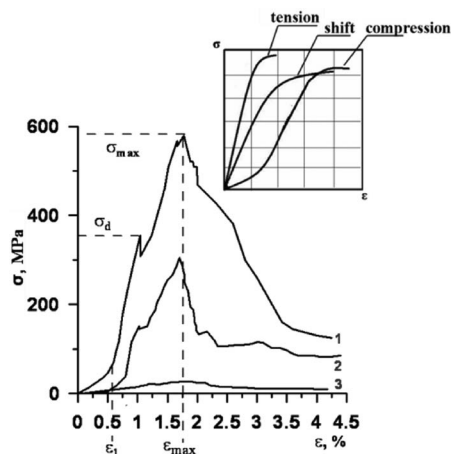

a)

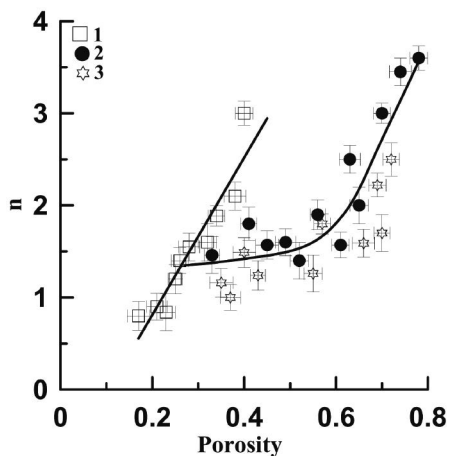

b)

Notations for part b) / Jelmagyarázat a b) ábra részhez:

- 1) ceramics $ZrO_2(MgO)$ with bimodal pore size distribution - $ZrO_2(MgO)$ / kerámiák bimodális pórusméret eloszlással;
- 2) ceramics $ZrO_2(Y_2O_3)$ with bimodal pore size distribution - $ZrO_2(Y_2O_3)$ / kerámiák bimodális pórusméret eloszlással;
- 3) ceramics $ZrO_2(Y_2O_3)$ with unimodal pore size distribution - $ZrO_2(Y_2O_3)$ / kerámiák uni-modális pórusméret eloszlással;

Fig. 3. Deformation diagrams in compression for ZrO_2 porous ceramics (Me_xO_y) and dependence of the exponent n on ZrO_2 ceramics porosity (Me_xO_y). Inset: Deformation diagrams of high porous foams with cellular structure under different types of loading.

3. ábra Porózus ZrO_2 kerámiák deformációs görbéje (a). (Me_xO_y) valamint az anyagtvényben szereplő n kitevő függése a ZrO_2 kerámia porozitásától (b) (Me_xO_y). Kiskép az (a) ábrán: A sejtés szerkezetű nagy porozitású habok deformációs görbéi különböző terhelési állapotokban.

Fig. 3.a – and (inset) [15] presents a chart deformation of highly porous foams with cellular structure for different types of loading. It is seen, that the form of the deformation diagrams during compression of foams σ - ϵ is similar to the diagrams of ZrO_2 porous ceramics (Y_2O_3), $ZrO_2(MgO)$, obtained in the present study.

Loading in the load - unload mode of studied ZrO_2 porous ceramics (Y_2O_3), $ZrO_2(MgO)$ in the initial section to strain values, ϵ_1 revealed no residual strain, which indicates that the elastic nature of the deformation of ceramics caused a reversible loss of stability of cellular elements.

Restructuring of σ - ϵ diagrams of ZrO_2 porous ceramics (Y_2O_3), $ZrO_2(MgO)$ in double logarithmic coordinates allows us to determine the value of the exponent in the law of deformation ($= K^n$) n from the experimental data.

Fig. 3.b shows the dependences of the exponent n in the law of deformation on porosity in ZrO_2 ceramics (Me_xO_y), from which it is evident that exponent n is increasing together with the increase of porosity of both systems, however, with porosity of 30 to 50%, the value of the exponent n is changed slightly and averages 1.3.

Fig. 4 represents the dependences of the stress that causes the first micro-damages σ_1 (1), and the ultimate strength σ_{max} (2) from porosity of ZrO_2 ceramics (Y_2O_3).

Increasing the porosity in ZrO_2 ceramics (Y_2O_3) with a bimodal distribution of pore size \approx from 30 to 80% led to the decrease in magnitude from $\sigma_d \approx 200$ to 50 MPa and a tensile strength σ_{max} of ≈ 400 to 100 MPa. With increasing porosity, the difference between the amount of stress that causes the first micro-damages σ_d and ultimate strength σ_{max} was reducing, which indicates that the emergence of micro-damages leads to the destruction of the material on the whole.

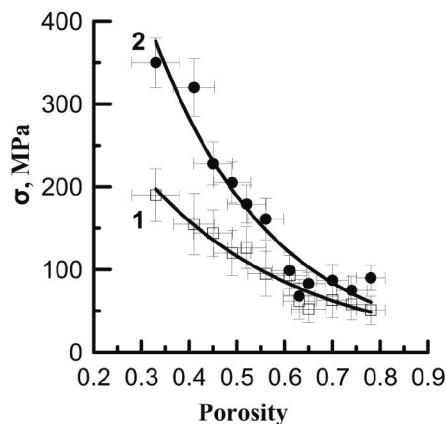

Fig. 4. Stress that causes the first microdamages σ_1 (1), and the ultimate strength σ_{max} (2) from porosity of ZrO_2 ceramics (Y_2O_3)

4. ábra A ZrO_2 kerámiák porozitálásában az első mikro károsodást okozó (1) valamint a maximális (2) feszültségek

Dependences of ultimate strength σ_{max} and stress that causes the first micro-damages σ_d in ZrO_2 porous ceramics (MgO), on the porosity had a similar form: the increase of the porosity from ≈ 15 to 45% resulted in a decrease of the σ_d value from ≈ 800 to 100 MPa and σ_{max} from 1200 to ≈ 200 MPa.

Fig. 5 shows the dependences of the strain at which the mechanical instability of the cellular elements appears ϵ_1 (1) and ultimate strain ϵ_{max} corresponding to ultimate strength

(2), on the surface area of pores in ZrO₂ ceramics (Me_xO_y) with a bimodal pore size distribution. The surface area of pores was calculated by the assumption of sphericity. Increasing the pore surface area led to an increase of the ultimate strain to ≈ 3.5%. Dependence of the deformation corresponding to the mechanical instability of the cellular elements on the pores surface area had a different form. Increase of the surface area of pores in ceramics had virtually no impact on the amount of strain ε₁, which averaged 0.5%.

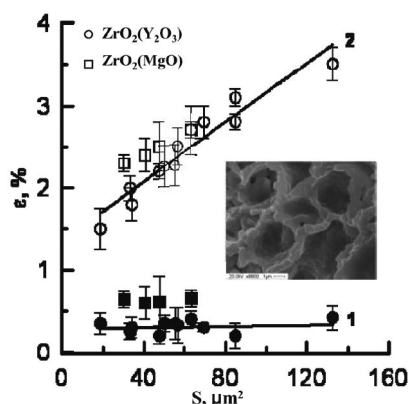

Fig. 5. The dependences of deformation ε₁ (1) and ultimate strain ε_{max} (2) from surface area of pores

5. ábra Az ε₁ deformáció (1) és az ε_{max} törőszilárdság (2) függése a pórusfelület nagyságától

4. Conclusions

It was shown that the structure of ZrO₂ ceramics (Me_xO_y), obtained from powders, consisting of hollow spherical particles with a porosity of 30 % is represented as a cellular carcass with a bimodal porosity, formed of a large pore close to a spherical shape and the pores that were not filled with the powder particles during the compaction. It was found that ZrO₂ ceramics (Me_xO_y) at a porosity of more than 30% with a bimodal pore size distribution demonstrate micromechanical instability during loading that is caused by deformation of the reversible cellular elements. For such ceramics the increase of pore volume is accompanied by an increase of strain in the elastic area.

5. Acknowledgments

Parts of this work had financial support by Tomsk State University Competitiveness Improvement Program, Siberian Branch Program #III.23.2.3 and RFBR project № 14-08-31087\14.

References

[1] Selivanov, Yu. – Loginova, E.: Thermal insulation ceramic materials with using binders; *Stroitelnyye materialy*, 2010, V. 7, pp. 49-51.
 [2] Gömze, A. L. – Gömze, L. N.: Ceramic based lightweight composites with extreme dynamic strength, 2013 *IOP Conf. Ser.: Mater. Sci. Eng.* 47 012033 <http://dx.doi.org/10.1088/1757-899X/47/1/012033>
 [3] Gömze, A. L. – Gömze, L. N.: Relations between the material structures and drying properties of ceramic bricks and roof tiles, *Építőanyag*, 2008, V.3, pp. 102-107. <http://dx.doi.org/10.14382/epitoanyag-jsbcm.2008.16>
 [4] Orosz, V. – Gömze, A. L.: Effect of ceramic additives on mechanical properties of alumina matrix composites, *Int. J. Microstructure and Materials Properties*, 2012, vol. 7, no. 2/3, pp. 205-219

[5] Chu, H. L. – Wang, C. L. – Lee, H. E. – Sie, Y. Y. – Chen, R. S. – Hwang, W. S. – Wang, M. C.: Effect of sintering process parameters on the properties of 3Y-PSZ ceramics, 2013 *IOP Conf. Ser.: Mater. Sci. Eng.* 47 012005 <http://dx.doi.org/10.1088/1757-899X/47/1/012005>
 [6] Kulkov, S. N. – Grigoriev, M. V.: Sintering of Al₂O₃ ceramics based on different sizes powders, *Építőanyag-JSBCM*, 2010, V.3, pp. 66-69 <http://dx.doi.org/10.14382/epitoanyag-jsbcm.2010.13>
 [7] Hernandez, J. G. M. – De La Torre, S. – Rangel, E. R.: Synthesis, microstructural analysis and mechanical properties of alumina-matrix cermets, *Építőanyag-JSBCM*, 2010. V.1, pp. 2-5 <http://dx.doi.org/10.14382/epitoanyag-jsbcm.2010.1>
 [8] Kulkov, S. N. – Buyakova, S. P. – Gömze, A. L.: Structure and mechanical properties of ZrO₂-based systems, *Építőanyag-JSBCM*, 2014, V.66, pp. 2-5 <http://dx.doi.org/10.14382/epitoanyag-jsbcm.2014.1>
 [9] Rundans, M. – Sperberga, I. – Sedmale, G. – Stinkulis, G.: Effect of sintering process and additives on the properties of cordierite based ceramics, 2013 *IOP Conf. Ser.: Mater. Sci. Eng.* 47 012012 <http://dx.doi.org/10.1088/1757-899X/47/1/012012>
 [10] Ismailov, A. – Levanen, E.: High-speed wear testing of selected ceramics in abrasive slurry, 2013 *IOP Conf. Ser.: Mater. Sci. Eng.* 47 012013 <http://dx.doi.org/10.1088/1757-899X/47/1/012013>
 [11] Rangel, E. R. – Silva, D. H. – Rojas, E. T. – Franco, E. M. – De La Torre, S. D.: Alumina-based composites strengthened with titanium and titanium carbide dispersions, *Építőanyag-JSBCM*, 2010. V.3, pp. 75-78 <http://dx.doi.org/10.14382/epitoanyag-jsbcm.2010.15>
 [12] Gömze, A. L. – Gömze, L. N.: Alumina-based hetero-modulus ceramic composites with extreme dynamic strength – phase transformation of Si₃N₄ during high speed collisions with metallic bodies; *Építőanyag*, 2009, V.2, pp. 38-42 <http://dx.doi.org/10.14382/epitoanyag-jsbcm.2009.7>
 [13] Kulkov, S. – Maslovskii, V. – Buyakova, S.: The non-Hooke's behavior of porous zirconia subjected to high-rate compressive deformation. *Technical Physics, The Russian Journal of Applied Physics*, 2002, V. 47, № 3, pp. 320-324.
 [14] Kalatur, E. S. – Kozlova, A. V. – Buyakova, S. P. – Kulkov, S. N.: Deformation behavior of zirconia-based porous ceramics. 2013 *IOP Conf. Ser.: Mater. Sci. Eng.* 47, 012004 <http://dx.doi.org/10.1088/1757-899X/47/1/012004>
 [15] Dement'ev, A.: Effect of cellular foam structures by the mechanical properties of the foams. *Mechanics of polymers*, 1970, V.4, pp. 594-602.

Ref:

Kalatur, E. S. – Buyakova, S. P. – Kulkov, S. N. – Gotman, I. – Kocserha, I.: *Porosity and Mechanical Properties of Zirconium Ceramics*
 Építőanyag – Journal of Silicate Based and Composite Materials, Vol. 66, No. 2 (2014), 31–34. p.
<http://dx.doi.org/10.14382/epitoanyag-jsbcm.2014.6>

Porózus cirkon-oxid kerámiák és mechanikai tulajdonságuk

A tanulmány nagyfinomságú ZrO₂ porból készített porózus kerámiák vizsgálatával foglalkozik. A minták sejtszerkezetes struktúrával, és 15–80% közötti porozitással rendelkeztek. A mechanikai vizsgálatok során kapott valamennyi deformációs görbe, kis deformációs zónájában egyedi, nem-lineáris jelleg figyelhető meg. A kis deformációhoz tartozó négyzetesen változó elaszticitás oka, a károsodott kerámia szerkezet elemi celláinak mechanikai instabilitása.
 Kulcsszavak: cirkon-oxid kerámiák; plazma kémiai módszer; porozitás; szemcseméret-eloszlás; mechanikai jellemzők

The Influence of Temperature on the Properties of ZrW_2O_8

SERGEY N. KULKOV • Tomsk State University, Institute of Strength Physics and Materials Science SB RAS, Russia • kulkov@ms.tsc.ru

ELENA S. DEDOVA • Tomsk State University, Institute of Strength Physics and Materials Science SB RAS, Russia • Isdedova@yandex.ru

FERNANDO PEDRAZA • University of La Rochelle, France • fpedraza@univ-lr.fr

JÁNOS ERDÉLYI • University of Miskolc, Dep. of Ceramics and Silicate Engineering, Hungary • erdelyijanos@hdsnet.hu

Received: 21. 06. 2014. • Érkezett: 2014. 06. 21. • <http://dx.doi.org/10.14382/epitoanyag-jsbcm.2014.7>

Abstract

A single-phase ZrW_2O_8 was prepared by the hydrothermal route via decomposition of $ZrW_2O_7(OH_{1.5}Cl_{0.5}) \cdot 2H_2O$ at 843 K. TEM, *in situ* high-temperature XRD and TG-DTA analyses of the ZrW_2O_8 synthesized were performed. The morphology of the material was represented as elongated particles with an intrinsic block structure. The stability fields of ZrW_2O_8 were determined. The ZrW_2O_8 demonstrated a negative thermal expansion behavior from 298 to 1023 K.

Keywords: Zirconium tungstate; Hydrothermal synthesis; Negative thermal expansion coefficient.

1. Introduction

Designing and developing highly-effective materials that remain stable under extreme conditions are among the primary tasks of modern materials science. One potential solution of this problem lies in the development of composite materials with an appropriate matrix and filler. The use of ceramics as a matrix is reasonable as they possess high mechanical strength, hardness and wear resistance while retaining its properties under high temperatures [1–6]. However, ceramics are known to display low toughness making them brittle enough for specific applications. Therefore, the introduction of internal stresses at the filler/matrix interface allows strengthening of the overall composite structure. Such internal stresses can be introduced through a filler that has a negative thermal expansion behavior (NTE) due to the opposite thermal expansion values of the source filler and matrix materials.

There is a class of materials with a negative thermal expansion behavior. More often than not, the contraction of such materials is small, anisotropic and appears in a narrow temperature range. In this respect, zirconium tungstate is a promising material due to a negative isotropic thermal expansion coefficient (CTE) $\alpha = -8.6 \cdot 10^{-6} K^{-1}$ within a wide temperature range from 0 to 1050 K [7].

The unique nature of its thermal behavior is explained by the presence of rigidly connected ZrO_6 octahedrons and WO_4 tetrahedrons in the structure which can rotate relative to one another at an angle of θ with increasing temperature, thereby initiating shrinkage of the material [8]. Variations in the volume concentration of zirconium tungstate would thus enable both to cause internal stresses in ceramic composites, and to make materials with a negative, positive or near zero thermal expansion.

It is known that the method of synthesis has an impact on material behavior under different influences, including an increase in temperature. The hydrothermal method allows for the synthesis of highly-homogeneous powders with small particle size. Zirconium tungstate synthesis using a hydrothermal

Elena Dedova

Graduated at the National Research Tomsk State University (Russia) in 2010. At present she is post-graduate student in Strength Physics and Materials Science SB RAS under the guidance Prof. Kulkov. Topic of her Ph.D. work is "Structure features and properties of tungstate zirconium and alloys Al - ZrW_2O_8 ". Elena Dedova is author and co-author of 25 articles.

Fernando Pedraza

is a professor of Laboratoire des Sciences de l'Ingénieur pour l'Environnement in the Université de La Rochelle (France). At present he is the vice-president of Université de La Rochelle and responsible for the international relations. Prof. Fernando Pedraza is a well known expert of aeronautical materials including high temperature oxidation and corrosion of turbines and has several scientific publications in these fields.

János Erdélyi

Graduated at the Mechanical Engineering Faculty in University of Miskolc (Hungary) in 2004. At present he is assistant professor in the Inst. Dep. of Ceramics and Silicate Engineering under the guidance of Prof. Gömze. He prepared and successfully completed his Ph.D. thesis in 2013. Dr. Erdélyi is author and co-author of 22 articles.

Prof. Sergey N. Kulkov

Prof. Kulkov is head of Department of Ceramics in the Institute of Strength Physics and Materials Science of the Russian Academy of Science since 1989. He has got scientific degrees „Doctor of Physics and Mathematical Sciences” in 1990. Since 1992 he's working as professor both in Tomsk State University and in Tomsk Polytechnic University. In 1997 he had a Soros Professor grant. His research works are represented in 5 books, more than 150 articles, 18 patents and many International Symposiums and Conferences. At present he is head of department „Theory of Strength and Mechanic of Solids”, member of „The American Ceramic Society” of „The APMI - International” and the DYM AT Society (France).

route is based on the decomposition of the precursor $ZrW_2O_7(OH_{1.5}Cl_{0.5}) \cdot 2H_2O$ at relatively low temperatures [9]. At present, there is nevertheless a lack of research on the properties of zirconium tungstate powder obtained using a hydrothermal route when heated. The objective of the work is to investigate the influence of temperature on the properties of ZrW_2O_8 .

2. Materials and experimental procedure

As source components, $Na_2WO_4 \cdot 2H_2O$ (p.a.), $ZrOCl_2 \cdot 8H_2O$ (puriss.) and HCl (puriss.) were used to make the precursor. Aqueous solutions of $Na_2WO_4 \cdot 2H_2O$ (0.5 mol/L), $ZrOCl_2 \cdot 8H_2O$ (0.25 mol/L), HCl (8 mol/L) were thoroughly mixed and moved to a Teflon-lined stainless steel autoclave. The hydrothermal reaction was conducted at 433 K for 36 hours. The product obtained was rinsed repeatedly with distilled water and dried at 383 K. To synthesize a monophasic ZrW_2O_8 powder, the synthesized precursor was annealed at 843 K for an hour in air. The thermal conditions were chosen according to the results reported in [9]. High-temperature *in situ* XRD analyses of the powder were conducted using a Bruker D8 diffractometer with filtered $CuK\alpha$ radiation and conducted at the Borekov Institute of Catalysis SB RAS. Particle form and size analyses were conducted with JEM-2100 transmission electron microscope (TEM). The particle distribution was determined using randomly-cross-section method on TEM photos.

3. Results and discussion

After the overall synthesis, the observations of the morphology of zirconium tungstate using a transmission electron microscopy showed that ZrW_2O_8 powder consisted of elongated particles with an intrinsic blocky structure (Fig. 1). The average block size varied from 20 nm to 50 nm. The distribution of elongated particles by size (longitudinal and lateral) had a unimodal nature. The average lateral size of the elongated particles was from 30 nm to 700 nm, and the average longitudinal size varied from 0.5 μm to 5.0 μm . The EDAX analysis demonstrated that the quantitative atom ratio (O ~ 60 at.%, W ~ 13 at.%, Zr ~ 27 at.% $\pm 2\%$) in the material obtained corresponded to the stoichiometry of ZrW_2O_8 compound (Zr:W = 1:2) [7]. The analysis of reflections observed in the micro-diffraction image indicates the formation of cubic structures.

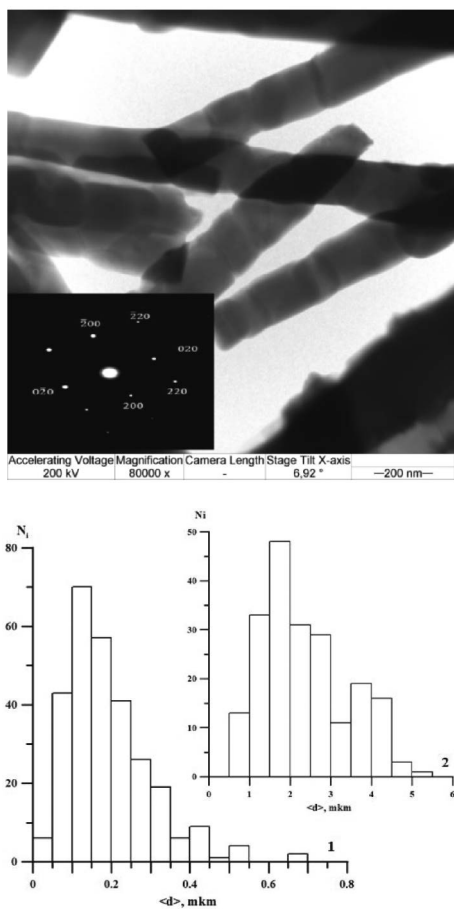

Fig. 1. TEM picture, microdiffraction, particle distribution by lateral (1) and longitudinal (2) ZrW_2O_8 sizes
 1. ábra A ZrW_2O_8 TEM felvétel, mikrodiffrakció és szemcseméret-eloszlás oldalirányban (1) és hosszirányban (2)

The investigations of phase transformation in a material at increasing temperature were performed *in situ*. The results of high-temperature *in situ* XRD observations are presented in Fig. 2. When ZrW_2O_8 is heated from room temperature to 423 K, a gradual decrease in the reflection intensity is observed in XRD pattern from surfaces (1 1 1), (2 2 1) and (3 1 0) up to its complete disappearance at temperatures beyond 473 K. According to [7, 9, 10], the disappearance of such peaks results from the transition from a low-temperature $\alpha - ZrW_2O_8$

($P2_13$) to a high-temperature modification $\beta - ZrW_2O_8$ ($Pa3$) induced by an increase in symmetry of a space group. An increase to 873 K leads to the appearance of weak diffraction lines corresponding to tungsten oxide and zirconium oxide. A further increase in temperature to 1023 K led to an increase in the peak intensity of WO_3 , the appearance of ZrO_2 lines and a decrease in ZrW_2O_8 reflections.

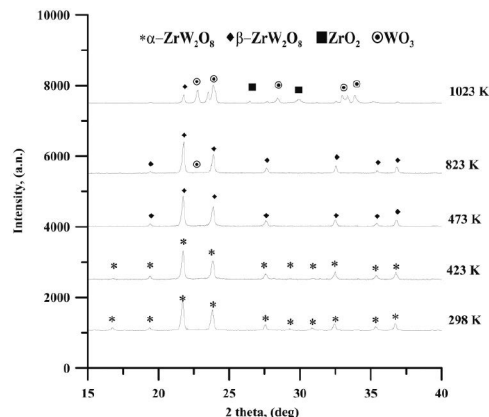

Fig. 2. The *in situ* high-temperature XRD pattern of ZrW_2O_8
 2. ábra A ZrW_2O_8 kerámia magas hőmérsékletű *in-situ* röntgen-diffraktogramjai

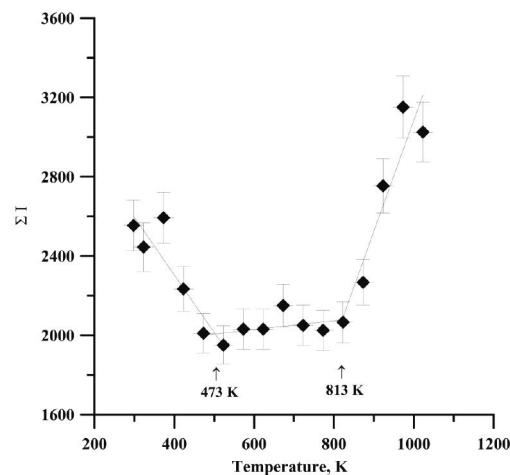

Fig. 3. The dependence between the temperature and the total intensity (ΣI) of all X-ray reflexes
 3. ábra A valamennyi röntgen reflexió teljes intenzitása a hőmérséklet függvényében

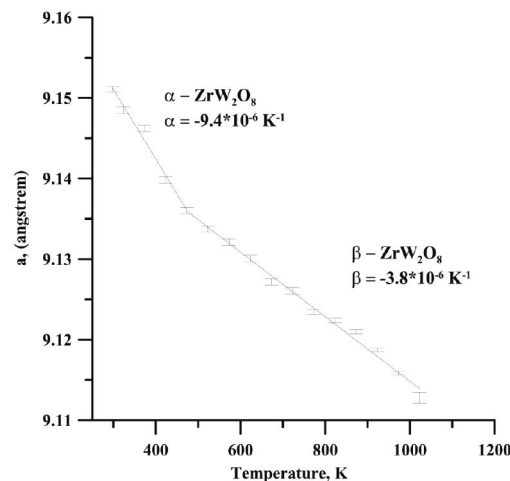

Fig. 4. The dependence between the temperature and the cubic lattice parameter of ZrW_2O_8
 4. ábra A ZrW_2O_8 kerámia köbös rácsparaméterének változása a hőmérséklet függvényében

The dependence of the total intensity (ΣI) of all X-ray reflections on temperature, based on the results of XRD analysis, is shown in Fig. 3. The curve can be unambiguously divided into 3 stages. As the temperature increases to 473 K, the total intensity decreases (stage 1). As the temperature increases from 473 K to 823 K (stage 2), the values of ΣI vary within the margins of experimental error. A further increase in temperature to 1023 K (stage 3), results in an increase in the total reflex intensity. The inflexion points where the slopes changed corresponded to 473 K and 823 K. According to the X-ray diffraction data, the decline in the total intensity in stage 1 was initiated by an $\alpha \rightarrow \beta$ transition and, as a consequence, by the disappearance of some reflections. At stage 2, there is only a high-temperature β -ZrW₂O₈. The increase in the total intensity at stage 3 can be explained by a pre-transitional phenomenon for forming new structures. Atoms in the zirconium tungstate structure begin to rearrange themselves in order to form sublattices of tungsten and zirconium oxides. Presumably, this movement of atoms precedes the decomposition of zirconium tungstate. It is known [7, 9, 10, 11] that zirconium tungstate loses its thermodynamic stability and decomposition into ZrO₂ and WO₃ occur at temperatures above 1050 K. According to the XRD analyses, weak lines of WO₃ and ZrO₂ were observed on diffraction patterns above 873 K. The intensity of the lines grew as the temperature is increased to 1023 K (Fig. 3).

The dependence of the cubic lattice parameter of ZrW₂O₈ on temperature is shown in Fig. 4. As seen in the graph, the lattice parameter decreased with an increase in temperature from 298 K to 1023 K, indicating a negative thermal expansion. Two segments with different slopes in relation to the x-axis can be outlined in the dependence. Changes in CTE occur at 473 K, which corresponds to the $\alpha - \beta$ transition. For each segment, the coefficient of thermal expansion was calculated at the following values of temperature: $\alpha = -9.4 \cdot 10^{-6} \text{ K}^{-1}$ from 298 K to 473 K, $\alpha = -3.8 \cdot 10^{-6} \text{ K}^{-1}$ from 473 K to 1023 K.

4. Conclusion

This paper studied the influence of temperature on the properties of zirconium tungstate powder obtained using a hydrothermal route. It shows that 800 K is the limit until which zirconium tungstate retains its crystal structure. A subsequent increase in temperature is accompanied by changes in ZrW₂O₈ structure induced by the appearance of WO₃ and ZrO₂ phase nuclei which precedes the decomposition of ZrW₂O₈ into two constituent oxides at temperatures above 1000 K. The phase transition from the low-temperature (α) to high-temperature (β) modification of cubic zirconium tungstate occurs at 200°C. The coefficients of thermal expansion of zirconium tungstate powder obtained using a hydrothermal route were: $-9.6 \cdot 10^{-6} \text{ K}^{-1}$ for α -ZrW₂O₈ and $-3.8 \cdot 10^{-6} \text{ K}^{-1}$ for β -ZrW₂O₈.

5. Acknowledgements

This work was supported by the grants ISPMS SB RAS III.23.2.3. Authors thank Tatyana Yu. Kardash from Borekov Institute of Catalysis SB RAS, shared use center "NANOTECH".

References

- [1] Buyakova, S. P. – Promakhov, V. V. – Kulkov, S. N.: Thermal tests and their effect on the micro- and macrostructure of nanocrystalline ZrO₂. *Powder Metallurgy and Metal Ceramics*. 2012, V. 54 (5-6), pp: 267– 272. <http://dx.doi.org/10.1007/s11106-012-9427-0>
- [2] Kocserha, I. – Gömze, A. L.: Friction properties of clay compounds. *Applied Clay Science*, 2010, V. 48 (3), pp. 425 – 430. <http://dx.doi.org/10.1016/j.clay.2010.01.017>
- [3] Gömze, A. L. – Gömze, L. N.: Alumina-based hetero-modulus ceramic composites with extreme dynamic strength – phase transformation of Si₃N₄ during high speed collisions with metallic bodies. *Építőanyag*. 2009/2. V 61 (2). <http://dx.doi.org/10.14382/epitoanyag-jsbcm.2009.7>
- [4] Chu, H. L. – Wang, C. L. – Lee, H. E. – Sie, Y. Y. – Chen, R. S. – Hwang, W. S. – Wang, M. C.: Effect of sintering process parameters on the properties of 3Y-PSZ ceramics, 2013 IOP Conf. Ser.: Mater. Sci. Eng. 47 012005 <http://dx.doi.org/10.1088/1757-899X/47/1/012005>
- [5] Ainabayev, A. – Arkhipov, M. – Baideldinova, A. – Omarova, K. – Ksandopulo, G.: Out-of-Furnace Synthesis of High-Temperature Ceramic Materials in the Revolving Reactor, 2013 IOP Conf. Ser.: Mater. Sci. Eng. 47 012044 <http://dx.doi.org/10.1088/1757-899X/47/1/012044>
- [6] Ershova, N. I. – Kelina, I. Yu.: High-temperature wear-resistant materials based on silicon nitride, *Építőanyag*. 2009/2. V 61 (2). <http://dx.doi.org/10.14382/epitoanyag-jsbcm.2009.6>
- [7] Mary, T. A. – Evans, J. S. O. – Vogt, T. – Sleight, A. W.: Negative Thermal Expansion from 0.3 to 1050 Kelvin in ZrW₂O₈, *Science*. 1996, V. 272, pp. 90–92. <http://dx.doi.org/10.1126/science.272.5258.90>
- [8] Pryde, A. K. A. – Hammonds, K. D. – Dove, M. T. – Heine, V. – Gale, J. D. – Warren, M. C.: Origin of the negative thermal expansion in ZrW₂O₈ and ZrV₂O₇, *J. Phys. Condens. Matter*. 1996, V. 8, pp. 10973–10982. <http://dx.doi.org/10.1088/0953-8984/8/50/023>
- [9] Kulkov, S. N. – Dedova, E. S. – Gubanov, A. I.: Investigation of phase transformation during the synthesis of zirconium tungstate. *Russian Physics Journal*. 2013, V. 56 (12/2), pp. 151–155.
- [10] Evans, J. S. O. – David, W. I. F. – Sleight, A. W.: Structural investigation of the negative-thermal-expansion materials ZrW₂O₈. *Acta Crystallographica*. 1999, V. 330, pp. 333–340. <http://dx.doi.org/10.1107/S0108768198016966>
- [11] Evans, J. S. O.: Negative thermal expansion materials. *The Royal Society of Chemistry*, Dalton Trans. 1999, pp. 3317–3326. <http://dx.doi.org/10.1039/A904297K>

Ref.:

Kulkov, S. N. – Dedova, E. S. – Pedraza, F. – Erdélyi, J.: Porosity and Mechanical Properties of Zirconium Ceramics
Építőanyag – Journal of Silicate Based and Composite Materials,
Vol. 66, No. 2 (2014), 35–37. p.
<http://dx.doi.org/10.14382/epitoanyag-jsbcm.2014.7>

A hőmérséklet hatása a ZrW₂O₈ kerámiák tulajdonságaira

A tanulmány nagytisztaságú ZrW₂O₈ kerámia vizsgálatával foglalkozik. Az egyfázisú ZrW₂O₈ kerámia, hidrotermális úton a ZrW₂O₇(OH_{1.5},Cl_{0.5})•2H₂O, 843 K-en történő hőbontásával került előállításra. A cirkónium-wolframátot TEM, TG-DTA valamint magas hőmérsékletű in-situ XRD vizsgálattal jellemezték. Az anyag morfológiáját tekintve saját blokkstruktúrával rendelkező jellegetes megnyúlt szemcsékből áll. Meghatározásra került a kerámia stabilitási intervalluma valamint a hőtágulási együtthatója, mely a 298-1023 K közötti tartományon negatív előjelű.

Kulcsszavak: cirkónium-wolframát; hidrotermális szintézis; negatív hőtágulási együttható

Foam Glass Ceramics as Composite Granulated Heat-Insulating Material

AFANASY S. APKARYAN ▪ Tomsk State University of Control Systems and Radioelectronics, Tomsk (Russia) ▪ Institute of Strength Physics and Materials Science SB RAS, Tomsk (Russia) ▪ asaktc@ispms.tsc.ru

SERGEY N. KULKOV ▪ Tomsk State University (TSU), Tomsk (Russia) ▪ Institute of Strength Physics and Materials Science SB RAS, Tomsk (Russia) ▪ kulkov@ms.tsc.ru

LÁSZLÓ A. GÖMZE ▪ University of Miskolc, Egyetemváros, Miskolc (Hungary) ▪ IGREX Engineering Service Ltd, Igri (Hungary) ▪ femgomze@uni-miskolc.hu ▪ igrex2009@yandex.ru

Received: 28. 06. 2014. ▪ Érkezett: 2014. 06. 28. ▪ <http://dx.doi.org/10.14382/epitoanyag-jsbcm.2014.8>

Abstract

Manufacturing technology for granulated glass-ceramic heat-insulating material made from crushed glass, clay and organic additives was developed. The effect of the basic physical characteristics of the components of the charge on the process of pore formation is studied. According to the research results, the basic parameters affecting the sustainability of the swelling glass are specified. A rational charge composition, thermal and gas synthesis mode are chosen such that the partial pressure of gases is lower than the surface tension of the melt. This enables the formation of granules with small closed pores and a vitrified surface. The regularities of the effect of composition and the firing temperature on the properties of the granules are determined. The resulting granulated heat-insulating material is produced with a bulk density of 260–280 kg/m³, and pellet strength of 1.74 MPa, thermal conductivity of 0.075 W/m °C, and water absorption of 2.6% by weight. The results are given of the study of the dependence of the thermal conductivity coefficient and mechanical strength of the granules on the bulk density.

Keywords: Carbon, clays, crushed glass, density, durability, granulate, glass-ceramics, heat-insulation, sawdust, thermal conductivity, water absorption.

1. Introduction

The advantage of foam glass compared to other well-known insulating materials is its unique combination of insulating and functional characteristics [1, 2], which enables the use of this material in various industrial spheres [3, 4] including heat insulation lightweight aggregate concretes as well [5, 6, 7].

The aim of this research is the experimental and theoretical justification of the feasibility of producing a competitive environmentally friendly insulation – granulated foam glass ceramic, which would provide effective thermal and physical characteristics for the construction industry and thermal engineering. For achieving this goal, the following tasks were set:

- Experimentally validate an increase in the functional, thermal and physical characteristics of foam glass ceramics by means of selection and optimization of the structural phase condition of granulated material.
- Study the physical and chemical processes of pore formation and crystallization of aluminum silicate hot melt during the formation of the phase composition and foam glass ceramic structure.

2. Materials and experiments

Crushed glass, clay, carbon and sawdust were used as the material for the production of granulated foam glass ceramic. In order to increase the mechanical strength of inter-pore partitions and the surface of granules and, consequently, the granule mechanical strength in general, clay was added to the composition, and as it decreased the hot melt viscosity, an organic additive – sawdust – was used to enable stable foaming with a gassing agent. Glass types with high foam glass production characteristics include: SiO₂ – 60...72,5%, Fe₂O₃ – 0...2,5%, CaO – 4...6,0%, MgO – 1,5...2,5%, Na₂O – 12,5...15,0%, Al₂O₃ – 1,2...1,57 [8].

2.1 Glass

Three types of glass (Table 1) were used in the experiments. The first type of the crushed glass was float (window) glass.

Type of glass	Glass chemical composition, %										
	SiO ₂	Al ₂ O ₃	Fe ₂ O ₃	CaO	MgO	R ₂ O	SO ₃	K ₂ O	Na ₂ O	Cr ₂ O ₃	BaO
Window glass	73.0	0.9	0.12	8.7	3.6	13.6	0.53	-	-	-	-
Bottle glass	70.7	4.0	0.65	6.5	3.5	-	-	-	14.5	0.15	-
Lamp glass SL96-1	71.9	1.5	0.1	5.5	3.5	-	-	0.15	16.1	-	2.0

Table 1. Chemical composition of the used crushed glass types
1. táblázat A vizsgálatokhoz használt üvegcserép kémiai összetétele

Dr. Afanasy S. Apkaryan

Dr. Apkaryan has PhD in Technical Sciences. He is head of Department and responsible for Nanotechnology in the Institute of Strength Physics and Materials Science of the Russian Academy of Science since 2005. Candidate of Technical Sciences. Specialists in the field of thermal physics and ceramic production. Associate Professor in Tomsk State University of Control Systems and Radioelectronics. Dr. Apkaryan is author or co-author of 2 books, 27 articles and 3 Russian patents.

Prof. Sergey N. Kulkov

Prof. Kulkov is head of Department of Ceramics in the Institute of Strength Physics and Materials Science of the Russian Academy of Science since 1989. He has got scientific degrees „Doctor of Physics and Mathematical Sciences” in 1990. Since 1992 he’s working as professor both in Tomsk State University and in Tomsk Polytechnic University. In 1997 he had a Soros Professor grant. His research works are represented in 5 books, more than 150 articles, 18 patents and many International Symposiums and Conferences. At present he is head of department „Theory of Strength and Mechanic of Solids”, member of „The American Ceramic Society” of „The APMI - International” and the DYM AT Society (France).

Prof. László A. Gömze

Establisher (in July 1st, 1999) and head of Department of Ceramics and Silicate Engineering in the University of Miskolc, Hungary. Since then 7 students from the department have successfully completed their PhD theses and 4 of them were managed by Prof. Gömze. He is author or co-author of 2 patents, 5 books and more than 250 scientific papers. Recently, he is the chair of the International Organization Board of ic-cmtp³ the 3rd International Conference on Competitive Materials and Technological Processes (2014) and ic-rmm² the 2nd International Conference on Rheology and Modeling of Materials (2015).

Chemical composition of windowpanes is the closest to this. Their distinctive characteristic is a low level of Al_2O_3 compared to other types of glass.

The second important source of crushed glass was green bottle glass. This type of glass has a high level of Fe_2O_3 – 0.65%, Al_2O_3 – 4.0%, Na_2O – 14.5%, which is an important factor for the process of foaming.

The third source of crushed glass was electric bulb glass SL96-1 from the Tomsk Electric-Bulb Factory with chemical composition described in *Table 1*.

During the production of granulated foam glass ceramics it is necessary to carry out the correction of the functional composition of a charge taking into account every type of glass used.

2.2 Clay

A range of clay deposits was studied in order to determine the local raw material base for the production of foam glass ceramics [9].

The best results were obtained using clay that is classified as pulverous loam, with a domination of SiO_2 – 70.73%; Al_2O_3 – 17.12% and Fe_2O_3 – 5.68% in its chemical composition. The presence of this type of clay in the charge leads to a decrease of water consumption to 3–4%, increasing the mechanical durability and fire resistance of the granules of foam glass ceramics (*Table 2*).

Type of particles	Size of particles, mm	Particle content, %
Clay	<0.005	20...32
Silt	0.005...0.05	68...80
Sand	0.05...1.0	absent

Table 2. Granulometric characteristics of particles
2. táblázat Az 5-10 mm szemcseátmérőjű duzzasztott agyag (Keramzit) és a 260 kg/m³ térfogat-sűrűségű kompozit üvegerámia-hab legfontosabb tulajdonságainak összehasonlítása

2.3 Organic additive

In contrast to traditional foam glass compositions, the distinctive characteristic of the charge composition proposed for the production of foam glass ceramics was using sawdust as an organic element of the charge.

Softwoods and hardwoods contain pentosans (a type of hemicellulose) that hydrolyze in the presence of water and turn into simple sugars that are soluble easily in water. Simple sugars prevent good adhesion of the charge particles with sawdust. Therefore, preference was given to softwoods as they contain 2-3 times more pentosans than hardwoods.

The balance of chemical agents in sawdust was about 50% carbon, 6.0% hydrogen, 44% oxygen and approximately 1.0% nitrogen.

2.4 Gassing agent

When justifying the choice of gassing agent, the conjunction of temperature intervals of hot melt appearance with required viscosity and formation of the peak partial pressure of gaseous products in organic burn off were taken into account. Carbon was used as the gassing agent.

In the course of the study the following charge composition was used (% by weight): crushed glass 67 – 84; clay 8 – 25; carbon 5 and sawdust – 3. The charge degree of fineness was 0.45–0.15 mm.

The granules were made in the following way: glass cullet was further crushed in a grinder to 1.5–3.0 mm, and then in a ball mill combined with sawdust to the particle specific surface area of 300–350 m²/kg. In such a way the sawdust was added to the charge during the moment of glass grinding, which enabled their pulverizing to a wood powder with an obtainment of a high shape factor of wood fiber (length-to-thickness ratio) equal to 4 and the size of particles no more than 560 microns. Grinding process of carbon and clay was also performed in the ball mill.

The obtained glass-wool and carbon-clay powders were dosed and loaded in a rod vibrating mill where they were jointly mechanically activated to a specific surface area of 400 m²/kg. The obtained charge was gaged with water (10–15% of the charge mass) for gaining the required plasticity, and then was formed into granules of 3–8 mm in size.

The experiments were carried out with a permanent carbon value of 5% and organic additives (sawdust) of 3%, as it was described above.

3. Results and discussions

Granule burning was carried out at a temperature of 830–850 °C within a sintering range of foaming mixtures equal to 4–6 minutes. When the charge contains 8% of clay there commences a formation of granules consisting of cells ranging from 0.135 to 2.7 mm in size, and occasionally connected with communicated channels (*Fig. 1*) and with an interpore partition thickness of 0.07–0.1 microns. The granule density was 200 kg/m³.

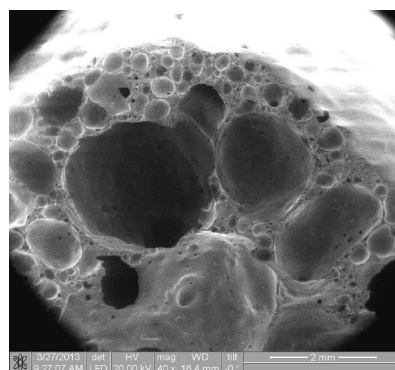
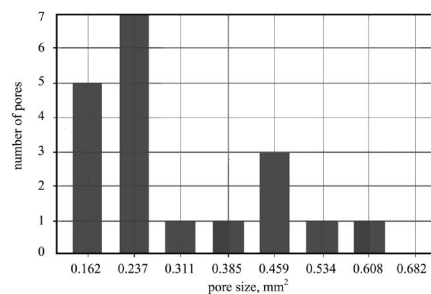

Fig. 1. Histogram of pore dispersion in quantity and size and pore structure of foam glass ceramics with 8% clay containment in the charge. Granule density is 200 kg/m³
1. ábra 8% agyagot tartalmazó duzzasztott üvegerámia-hab granulátum pórus szerkezetének hisztogramja. A granulátum sűrűsége 200 kg/m³

The formation and steadiness of the foam depends on the surface energy at the boundary between gas and liquid. When adding 10% of clay to the charge, the surface tension and free energy of the system, which forms fragile foam, start to increase. As the proportion of clay starts to increase beyond 25%, the boundary surface between phases starts to decrease; the pores and the gas emission mutually combine, and the foam settles.

In order to overcome this challenge the decision was made to use sawdust as an organic additive in the charge. It was estimated experimentally that adding up to 3% of sawdust with a simultaneous increase of the foaming temperature up to 830 °C and the time of pore formation up to 5 minutes, the amount of gases and their partial pressure would increase. Furthermore, the viscosity of the hot melt begins to decrease and the particle sintering commences, leading to the formation of glass ceramic mass.

When increasing the temperature by 70–110 °C higher than the glass softening point, sodium sulphate reacts with coke carbon and the carbon of burning organic additives (sawdust) with the formation of carbon monoxide:



The presence of clay facilitates an increase of the glass softening point and the bloating phase, and containment up to 5.0% of carbon and up to 3% of sawdust enables the formation of a rather large amount of gas with high partial pressure. The charge composition is made in such a way that the gas partial pressure is lower than the surface tension of a hot melt, which enables an increase in the dividing surface between phases and equal distribution of pores in a hot melt.

In the process of foaming, the pores mutually combine at a low rate. The gases in the pores work against the energy caused by surface tension. The presence of clay in a hot melt significantly increases the energy of the surface tension, and the gas pressure in pores decreases as the pores diminish. As a result there are up to 92% of closed pores of 0.2–0.4 mm in size, with a thickness of the dividing partition within the bounds of 0.07–0.1 micron up to 12 microns.

According to the silicate foam formation mechanism, a maximum of closed cells is formed under the foaming of homogeneous systems with an optimal viscosity of hot melts, in which smooth foaming, and, at the same time, a high fixity of formed foam caused by its structural-mechanical factor are provided (Fig. 2). The granule density is 260 kg/m³.

Mutual combination and formation of open pores occurs in the initial foaming period – the period of free gas exit. This process stops as the gas pressure in the system equalizes. Under a relatively high hot melt viscosity, the equilibrium state of the system is gained much slower. The formation of closed pores in foam glass ceramics is enabled by adding fusible clay into the charge, which decreases the viscosity of a hot melt and significantly increases its plasticity, and at the same time raises the mechanical strength of pore partitions. As a result, the pore partitions are not pierced and the formation of new pores occurs independently, without the impact of gassing processes in neighboring pores.

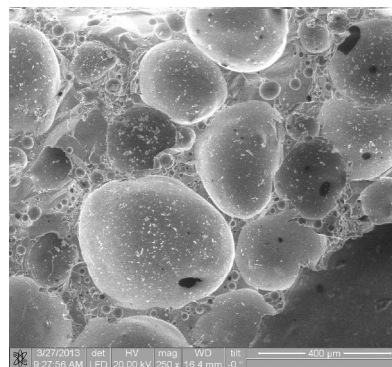
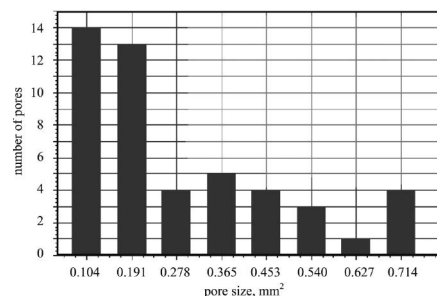

Fig. 2. Histogram of pore dispersion in quantity and size and pore structure of foam glass ceramics with 10% clay containment in the charge. Granule density is 260 kg/m³

2. ábra 10% agyagot tartalmazó duzzasztott üveggerámia-hab granulátum pórus szerkezetének hisztogramja. A granulátum sűrűsége 260 kg/m³

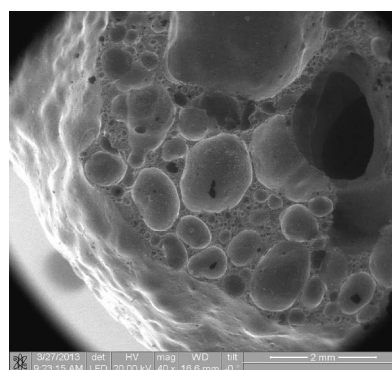
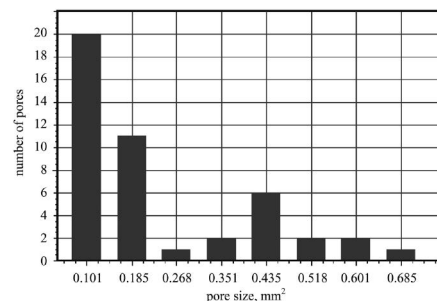

Fig. 3. Histogram of pore dispersion in quantity and size and pore structure of foam glass ceramics with 25% clay containment in the charge. The granule density is 290 kg/m³

3. ábra 25% agyagot tartalmazó duzzasztott üveggerámia-hab granulátum pórus szerkezetének hisztogramja. A granulátum sűrűsége 290 kg/m³

Clay as a fusible additive in the rational composition of a charge plays the role of stabilizer. The stabilizing action of clay enables the formation of a so-called energy barrier, which increases the mechanical strength of partitions with the narrowest thickness. Increasing the clay proportion up to 25% enables the rise of

the hot melt viscosity, and an increase in the thickness and mechanical strength of the walls. Gas pressure in pores is not enough for their size increase. As a result small pores start to appear – from 0.036 to 0.135 microns, and the thickness of pore partitions expands and varies from 0.07–0.1 micron to 50 microns (Fig. 3). The granule density is 290 kg/m³.

The glassy layer formed on the granular surface enables the formation of a solid surface at the stage of bloating, as a result of which the mechanical compressive strength is increased and the water absorption decreases.

The formation of a porous structure during heating is divided into the following stages:

- Synthesis – formation of sintered material during heating to the sintering temperature range;
- Bloating – the process of volume and structural changing of material;
- Annealing – a special mode of cooling.

As follows from the study, an optimal thermal profile for the sintering regime and granular porization was determined (Fig. 4).

A thermal shock in the zone of high temperatures (830°C) in areductive conditions with 3.0% CO containment is characteristic for granular thermal processing. Furthermore, the mechanical strength comes to the maximum while granules are in the high temperature zone for 5-6 minutes. Thermal cycle *foaming* → *pore formation* → *annealing* (Fig. 4) provides an optimal time for granules in the foaming zone, regulating the size and the quantity of pores and prevents the process of bubble coalescence (increasing of pore size), for which greater time in the high temperature zone is required.

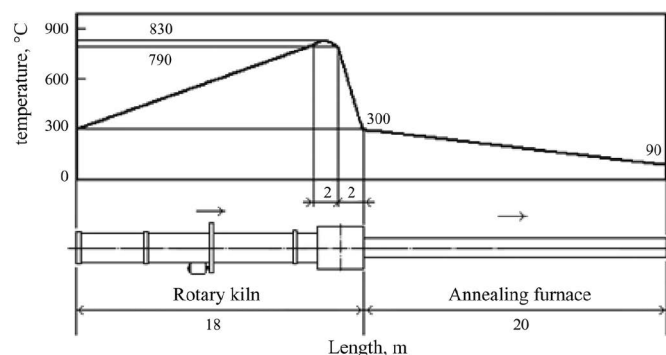

Fig. 4. Optimal scheme of thermal cycle of foam glass ceramic granule sintering and porization

4. ábra Optimális hőkezelési görbe jó pórusszerkezetű üvegkerámia-hab granulátum létrehozásához

When granules stay in the high temperature zone more than 10 minutes, the probability of dissipative phenomena is increased, i.e. the extension and collapsing of pores. As the quantity of pores decreases, they start to expand by up to 2 mm, and the partitions become fragile and thin. When foam glass ceramic is foaming, the structure of the pores being formed is mainly determined by rheological characteristics of an alumina-silicate melt. The strength of pore membrane during the extension depends upon the viscosity of the melt, which provides the solidity of partitions and the surface strength in the high temperature zone.

Annealing is necessary to fix the pore structure and to relieve temperature stresses in the pores. Experiments have shown that the best result is achieved when annealing starts

at a temperature of 300 °C and ends at 90 °C. The rate of the temperature decrease is 11.6 degree/min. Such a high rate, without granule breakage and shelling of the surface, is enabled by the presence of clay in the charge and a long period of crystallization. Clay enables the formation of fire resistant alumina-silicate matrix.

To study the dependence of the thermal conductivity coefficient on medium density and compressive strength, studies with a change of rational composition of a charge were conducted. As the studies showed (Fig. 5) all three criteria – mechanical compressive strength, density and thermal conductivity – depend on the size and the quantity of pores, and on the thickness and the composition of partitions. When density is increased the thermal conductivity and the granular mechanical strength grow by means of increasing the percentage of clay in the composition of charge. As the temperature increases, the melt viscosity decreases. Gas pressure rises and the shear action of capillary forces develops. The pores get filled with a fluid phase, which leads to a thickening of the material.

The studies of temperature-time regimes within space factors determined an optimal component proportion in the charge for obtaining the required porous structure. Moreover, small closed pores equally dispersed over the granule surface appear (Fig. 2). The granular mechanical strength is between 0.82–1.74 MPa.

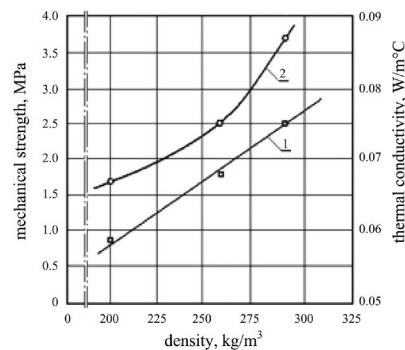

Fig. 5. Dependence of foam glass ceramic serviceability on its density

1 – Mechanical strength, (MPa); 2- thermal conductivity, W/m. °C)

5. ábra Üvegkerámia-hab granulátum legfontosabb tulajdonságainak függése a térfogatsűrűségről

1 – Mechanikai szilárdság (MPa); 2 – Hővezetési tényező (W/m°C)

Foam glass water absorption depends upon the pore characteristics: their size, quantity and structure (closed and open). Low water absorption is one of the most important factors in choosing the composition of a charge, as this parameter is inversely dependent both upon the density (Fig. 6) and thermal conductivity coefficient.

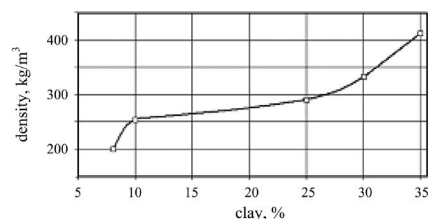

Fig. 6. The impact of clay proportion in the charge on the density of foam glass ceramics

6. ábra Üvegkerámia-hab granulátum térfogatsűrűségének függése a nyersanyagkeverék agyagtartalmától

The results of the water absorption test for foam glass ceramics are shown in Fig. 7.

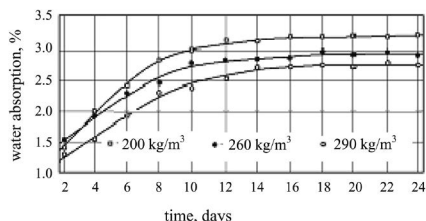

Fig. 7. The change of foam glass ceramic granule water absorption depending on the density change

7. ábra Üvegkerámia-hab granulátum vízfelvételeének függése a térfogatsűrűsétől

During the tests of granular foam glass ceramics with 260 kg/m³ density to determine thermal conductivity, strength, water absorption and operating temperature, physical technical characteristics were obtained, with a significant difference from expanded clay and other insulating materials of the same density (Table 3).

No	Factor	expanded clay	granular foam glass ceramics
1	Pour density, kg/m³	500 - 550*	260
2	Flammability	Non-flammable	Non-flammable
3	Thermal conductivity, W/m. °C	0.065 - 0.097	0.075
4	Compressive strength, MPa	1.7 - 2.5	1.74
5	Water absorption, m%	8 - 20	2.6*
6	Upper operating temperature, °C	Up to 600	620

* Traditional industrially manufactured expanded clay with closed porosity, with water absorption of 6-9% by volume

Table 3. Results of comparing granular foam glass ceramics with 260 kg/m³ density and expanded clay gravel fractions of 5-10 mm

3. táblázat Habosított üveg-kerámia granulátum (sűrűség 260 kg/m³) jellemzőinek összehasonlítása duzzasztott agyagkavicéval (5-10 mm szemmagyság)

4. Conclusion

It has been established that the products are fragile when the clay content in the charge is lower than 8%, with a low mechanical strength and large pores; if the clay content is higher than 25% then the granules are close in their physical and technical properties to expanded clay.

Granulated foam glass ceramics with a density of 260 kg/m³ have low thermal conductivity and water absorption, and high compressive strength and operating temperature.

The developed technology provides the opportunity to produce granulated foam glass ceramic products of various geometric shapes – plates, blocks, segments, shells and enables them to be recommended as an effective heat-insulating material not only in construction but also in thermal engineering [10, 11].

5. Acknowledgement

Parts of this work had financial support by Tomsk State University Competitiveness Improvement Program and Siberian Branch Program #III.23.2.3.

References

[1] Schill, F.: Foam glass – Production and use; (translated to Russian from Check) 1965 *Sroyizdat*, Moscow (Russia) 307 p.
 [2] Lang, G.: Common problems with the insulation on installations; *Chemical processing*, January 1984.

[3] Wen, G. – Zheng, X. – Song, L. – Huang, X. X.: Effects of P₂O₅ and sintering temperature on microstructure and mechanical properties of lithium disilicate glass-ceramics, 2009 *Acta Materialia*, V. 55, pp. 3583-3591 <http://dx.doi.org/10.1016/j.actamat.2007.02.009>
 [4] Santos, F. A. – Fernandes, M. H. F. V. – Davim, E. – Pinatti, D. G. – Lazar, D. R. R. – Santos, C.: Crystalization of Biomaterial, the lithium disilicate, obtained from rice husk silica, 2013 *IOP Conf. Ser.: Mater. Sci. Eng.* 47 012003 <http://dx.doi.org/10.1088/1757-899X/47/1/012003>
 [5] Hoffmann, L. – Józsa, Zs. – Nemes, R.: Glass Waste Lightweight aggregate for concrete from glass wastes “Geofil-Bubbles” – use options, (in Hungarian), *Építőanyag*, 2003, V.1, pp. 13-17. <http://dx.doi.org/10.14382/epitoanyag-jsbcm.2003.3>
 [6] Mladenović, A. – Šput, J. S. – Ducman, V. – Škapin, A. S.: Alkali-silica reactivity of some frequently used lightweight aggregates, 2004, *Cement and Concrete Research* 34, 1809-1816 <http://dx.doi.org/10.1016/j.cemconres.2004.01.017>
 [7] Bumanis, G. – Bajare, D. – Locs, J. – Korjakins, A.: Alkali-silica reactivity of expanded glass granules in structure of lightweight concrete, 2013 *IOP Conf. Ser.: Mater. Sci. Eng.* 47 012022 <http://dx.doi.org/10.1088/1757-899X/47/1/012022>
 [8] Demidovich, B.: Production and use of foam glass; *Science and technology publishing*, 1972 Minsk (Belorussia), 304 p
 [9] Kudyakov, A.: Minerals of Tomsk region and their rational use of concrete technology; / *TSU publishing*, 1991 Tomsk (Russia), 222 p.
 [10] Russian Federation invention patent № 2374191. “A method of producing of a granular foam glass ceramics” A. Apkarian, V. Khristyukov, reg. the 27th of November 2009
 [11] Apkaryan, A. S. – Khristyukov, V. G. – Smirnov, G. V.: Granulated foam glass ceramic – a promising heat insulating material. *Glass and Ceramics, Springer New York Consultants Bureau*. 2008, T. 65 . № 3 - 4. pp. 74-76. <http://dx.doi.org/10.1007/s10717-008-9018-1>

Ref.:

Apkaryan, A. S. – Kulkov, S. N. – Gömze, L. A.: *Foam Glass Ceramics as Composite Granulated Heat-Insulating Material* *Építőanyag – Journal of Silicate Based and Composite Materials*, Vol. 66, No. 2 (2014), 38–42. p. <http://dx.doi.org/10.14382/epitoanyag-jsbcm.2014.8>

Habosított üveg-kerámia granulátumok, mint hőszigetelő kompozit anyagok

A pórusképzés fizikai és fizikokémiai folyamatának vizsgálataira támaszkodva a szerzők gyártási technológiát dolgoztak ki habosított üveg-kerámia hőszigetelő granulátumok előállítására örölt üvegcserep, agyag valamint szerves adalékanyag keverékéből. A kutatások eredményeként meghatározásra kerültek az üveg habosodását befolyásoló tényezők. Meghatározásra került az a rakat-összetétel intervallum, amelynél biztosított, hogy a pórusszerkezetet létrehozó, termikus bomlás során keletkező szintézisgáz parciális nyomása kisebb legyen az öt burokként körbevevő megolvadt anyag felületi feszültségénél. Ennek köszönhetően a duzzasztás – habosítás – során üvegesedett felületű zártpórusok sokaságát tartalmazó, megfelelő nyomószilárdsággal bíró anyagszerkezet jön létre, alacsony térfogat-sűrűséggel és vízfelvétellel. A duzzasztott üveg-kerámia szemcsék sűrűségét, hővezetési tényezőjét, vízfelvételt és nyomószilárdságát a szerzők a nyersanyag-összetétel és az égetési hőmérséklet változtatásával szabályozták. A hőszigetelő adalékanyagként történő hasznosíthatóság szempontjából legígéretesebbnek a 260–280 kg/m³ térfogat-sűrűségű, 1,74 MPa szemcseszilárdságú, 0,075 W/m °C hővezetési tényezővel rendelkező és max. 2,6% vízfelvételű hab-granulátumokat eredményező keverék-összetétel és égetési technológia bizonyult.

Kulcsszavak: szén, agyag, örölt üveg, sűrűség, tartósság, granulátum, üveg-kerámia, hőszigetelés, fűrészpórus, hővezetési tényező, vízfelvétel



EUROCORR 2014

EUROPEAN CORROSION CONGRESS

8 - 12 September 2014 - Pisa, Italy

organised by:



The annual event of the
European Federation of Corrosion

Associazione Italiana di Metallurgia – AIM will host EUROCORR 2014, the 364th event of the EFC-European Federation of Corrosion, which will be held in Pisa, Italy, from 8 - 12 September 2014. This premier event on Corrosion, will return to the same Latin land – Italy – where Pliny the Elder for the first time coined the phrase „ferrum corruptur“. The main Theme of EUROCORR 2014 will be „Improving materials durability: from cultural heritage to industrial applications“ and it will aim at asserting the critical role of corrosion science, technology and engineering in extending the life of materials.

Sessions – Workshops

- | | | | |
|--|--|--|--|
| 01. Corrosion and Scale Inhibition (WP1) | 10. Corrosion in Oil & Gas Production (WP 13) | 12. Corrosion in the Refinery Industry (WP 15) | B. WS: Corrosion Reliability of Electronics Devices |
| 02. Corrosion by Hot Gases and Combustion Products (WP 3) | 11.1. Metallic Coatings | 13. Cathodic Protection (WP 16) | C. JS: High Temperature Corrosion in the Refinery, Petrochemical & Chemical Industries (WP 3 & 15) |
| 03. Nuclear Corrosion (WP 4) | 11.2. Inorganic Coatings | 16. Corrosion of Polymer Materials (WP 19) | I. JS: Interplay of Mechanics and Corrosion in Surface and Bulk Degradation (WP 8 & 15) |
| 05. Corrosion Mechanisms, Methods and Modelling (WP 6 & 8) | 11.3. Organic Coatings | 17. Corrosion & Corrosion Protection of Drinking Water Systems (WP 20) | |
| 07. Marine Corrosion (WP 9) | 11.4. Pretreatments | 18. Corrosion of Archaeological and Historical Artefacts (WP 21) | |
| 08. Microbial Corrosion (WP 10) | 11.5. Self-healing Coatings | 19. Corrosion in Aerospace (WP 22) | |
| 09. Corrosion of Steel in Concrete (WP 11) | 11.6. Coatings for High Temperatures (WP 3 & 14) | | |

contacts: **eurocorr 2014 – associazione italiana di metallurgia** – email: eurocorr2014@aimnet.it – www.eurocorr2014.org



9th European Trade Fair & Forum for Composites, Technology and Applications

7 - 9 October 2014
Messe Düsseldorf,
Germany



Fair topics

COMPOSITES EUROPE is the industry event for composite materials, manufacturing, processing and application.

Exhibition areas

- Raw materials (Resins, Fabric, Thermoplastics, Additives)
- Semi-finished products, intermediate products and finished- products
- Processing technology
- Machines, Equipment, Consumables
- Construction, simulation
- Services

Contact +49 211 90191-330 info@composites-europe.com www.composites-europe.com

The Influence of Porosity on the Elasticity and Strength of Alumina Ceramics

NIKOLAI L. SAVCHENKO ▪ Institute of Strength Physics and Materials Science SB RAS, Tomsk (Russia)
IRINA N. SEVOSTYANOVA ▪ Institute of Strength Physics and Materials Science SB RAS, Tomsk (Russia)
TATIANA YU. SABLINA ▪ Institute of Strength Physics and Materials Science SB RAS, Tomsk (Russia)
LUCIA MOLNÁR ▪ University of Miskolc, Egyetemváros, Miskolc (Hungary)
RÓBERT GÉBER ▪ University of Miskolc, Egyetemváros, Miskolc (Hungary)
LÁSZLÓ A. GÖMZE ▪ University of Miskolc, Egyetemváros, Miskolc (Hungary) ▪ femgomze@uni-miskolc.hu
SERGEY N. KULKOV ▪ Institute of Strength Physics and Materials Science SB RAS, Tomsk (Russia) ▪ Tomsk State University (TSU), Tomsk (Russia) ▪ kulkov@ms.tsc.ru
LUDMILA N. GÖMZE ▪ IGREX Engineering Service Ltd, Igrici (Hungary) ▪ igrex2009@yandex.ru
 Received: 28. 06. 2014. ▪ Érkezett: 2014. 06. 28. ▪ <http://dx.doi.org/10.14382/epitoanyag-jsbcm.2014.9>

Abstract

This work investigates the behavior of porous alumina ceramics (within the porosity range of 18% to 70%) when subjected to deformation by compression and shear. The analysis of strain-deformation curves showed that there was a transition from a typically brittle state for relatively dense ceramics ($\leq 20\%$ porosity), to a pseudo-plastic one with a high rate of porosity (above 50%). The values of the modulus of elasticity, shear modulus and Poisson's ratio decrease with an increase in volume in the pore space of Al_2O_3 ceramics, which correlates with the appearance of multiple cracking during the deformation of ceramics with a high level of porosity.
 Keywords: Alumina, deformation, modulus of elasticity, plasticity, porosity, shearing, strain, strength, stress.

1. Introduction

It is known that the porosity of brittle materials can have significant influence on their physical (mechanical, thermal, electrical) properties. Young's modulus, shear modulus and Poisson's ratio are essential parameters in the studies of advanced material mechanics [1-3]. In addition, the macroscopic behavior of ceramics can vary from brittle to quasi-plastic depending on the pore space volume [3]. That is why the investigation of the evolution of deterioration in a brittle porous material at different levels of scale and the subsequent damage depending on the deformation rate, constraint, etc. is of considerable interest [4-9] in terms of the emergence of a structural hierarchy of deformation and failure in similar brittle materials (ceramics, stones).

The objective of the work is to study the relations between parameters such as porosity, compressive strength, Young's modulus, shear modulus, measured in the process of mechanical loading under compression and shear, as well as structures of damage and deformation in alumina ceramics.

2. Experimental materials and methods

Al_2O_3 ceramics with different porosity values (18%-70%) were made of powders obtained via thermal decomposition of aqueous nitric-acid metallic salt solutions in high-frequency discharge plasma [10]. The initial powders and a 3% polyvinyl alcohol solution were pressed by a hydraulic press under 10 kN/cm² pressure in steel die molds in order to obtain cylindrical (10 mm in diameter, 15 mm in height) and cubic (10 mm each side) shapes.

Nikolai L. Savchenko, PhD

Education: 1987: Tomsk Polytechnic University-engineer.1991-1994: Institute of Strength Physics and Materials Science of the Russian Academy of Sciences in Tomsk - PhD student. 1995: PhD.degree from the Institute of Strength Physics and Materials Science of the Russian Academy of Sciences in Tomsk. Field of research: Structure and mechanical property of porous ceramics based zirconia and alumina.

Tatiana Yu. Sablina, PhD

Education: 1989: Tomsk Polytechnic University-engineer.1991-1994: Institute of Strength Physics and Materials Science of the Russian Academy of Sciences in Tomsk - PhD student. 1995: PhD.degree from the Institute of Strength Physics and Materials Science of the Russian Academy of Sciences in Tomsk. Field of research: Structure and mechanical property of porous ceramics based zirconia and alumina.

Irina N. Sevostyanova, PhD

Education: 1987: Tomsk Polytechnic University-engineer.1993-1996: Institute of Strength Physics and Materials Science of the Russian Academy of Sciences in Tomsk - PhD student. 2001: PhD.degree from the Institute of Strength Physics and Materials Science of the Russian Academy of Sciences in Tomsk. Field of research: Structure and mechanical property of porous ceramics based zirconia and alumina.

Róbert Géber, PhD

has finished his MSc at the Materials Science and Engineering Faculty in University of Miskolc (Hungary) in 2007. Under guidance Prof. Gömze he prepared and successfully completed his PhD thesis in 2013. At the present time he is assistant professor in the Inst. Dep. of Ceramics and Silicate Engineering and author or co-author more than 20 articles

Lucia Molnár

is a BSc student at the Materials Science and Engineering Faculty in University of Miskolc (Hungary) and under guidance Prof. Gömze she is participating in the research works which are made under collaboration agreement between Tomsk State University (Russia) and University of Miskolc (Hungary).

Prof. Sergey N. Kulkov

Prof. Kulkov is head of Department of Ceramics in the Institute of Strength Physics and Materials Science of the Russian Academy of Science since 1989. He has got scientific degrees „Doctor of Physics and Mathematical Sciences” in 1990. Since 1992 he's working as professor both in Tomsk State University and in Tomsk Polytechnic University. In 1997 he had a Soros Professor grant. His research works are represented in 5 books, more than 150 articles, 18 patents and many International Symposiums and Conferences. At present he is head of department „Theory of Strength and Mechanic of Solids”, member of „The American Ceramic Society” of „The APMI - International” and the DYM AT Society (France).

Prof. László A. Gömze

Establisher (in July 1st, 1999) and head of Department of Ceramics and Silicate Engineering in the University of Miskolc, Hungary. Since then 7 students from the department have successfully completed their PhD theses and 4 of them were managed by Prof. Gömze. He is author or co-author of 2 patents, 5 books and more than 250 scientific papers. Recently, he is the chair of the International Organization Board of ic-cmp³ the 3rd International Conference on Competitive Materials and Technological Processes (2014) and ic-rmm² the 2nd International Conference on Rheology and Modeling of Materials (2015).

Dr. Ludmila N. Gömze

has finished her MSc as civil engineer in the Moscow State Construction-Engineering University (Russia) in 1974. Since that time she lives in Hungary and has a wide range working experiments as engineer. At present time she is the managing director of the IGREX Engineering Service Ltd and is author or co-author more than 30 scientific articles.

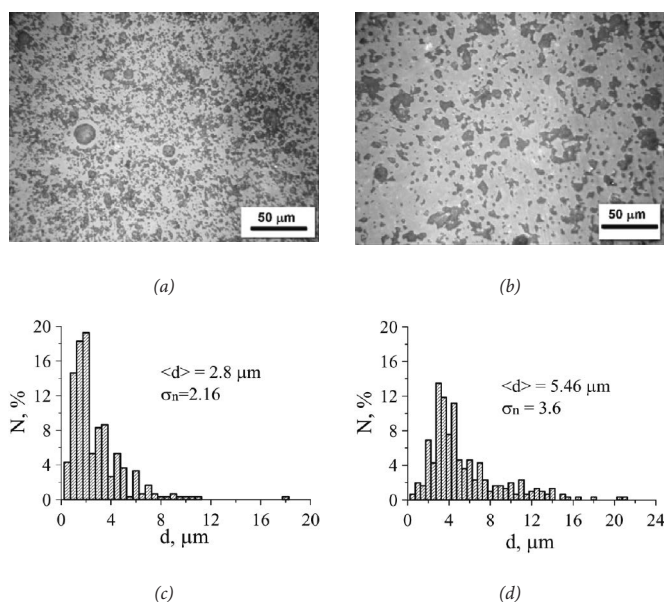

Fig. 1. Pore structure (a, b) and pore size distribution (c, d) of Al_2O_3 ceramics after sintering at a temperature of: 1400°C – (a, c), 1600°C – (b, d).
1. ábra Az 1400°C – (a, c) és 1600°C – (b, d) hőmérsékleten szinterelt Al_2O_3 kerámiák anyagszerkezete a pórusokkal (a, c) és pórusméret eloszlása (b, d)

Sintering was performed in air at temperatures ranging from 1000 to 1650 °C with an isothermal exposure time of one hour. The density of the sintered specimen was measured using the geometrical method. Residual porosity was calculated from the ratio of theoretical density to measured density, considering the phase composition of the obtained materials. The material structure after sintering was studied by optical metallography.

The specimens were exposed to mechanical tests in compression and shear by an universal testing machine Instron 1185, with simultaneous recording of the loading diagram. The traversal (loading) rate was 0.2 mm/min. On the σ - ε curves, a straight-line segment was outlined which corresponded with elastic deformation. Effective modulus of elasticity (E) and shear modulus (G) were defined as the angle of a tangent line slope to a straight-line segment of the σ - ε function curve.

3. Results and discussion

Investigations of ceramics structure after sintering showed that in specimens sintered at low temperatures, high porosity was observed and these pores were advantageously interpenetrating. The pore structure of Al_2O_3 ceramics sintered at 1400°C and 1600°C is shown in Fig. 1.a,b. With an increase in sintering temperature, along with decrease in pore space volume, an increase in the average pore size was observed (Fig. 1.c,d) due to the consolidation of fine pores into larger ones. According to X-ray structure analysis data, at all sintering temperatures Al_2O_3 is in a stable α -phase.

The comparison of σ - ε diagrams, obtained after testing ceramics with different porosity levels in compression, showed that their behavior depends on the pore space volume. The σ - ε curve analysis of 20% porous ceramics proved that they are linear functions until material destruction, (Fig. 2.a) while deviations from the linearity (Fig. 2.b) are observed in ceramics with a higher porosity of 20% to 50% in the area of high stresses.

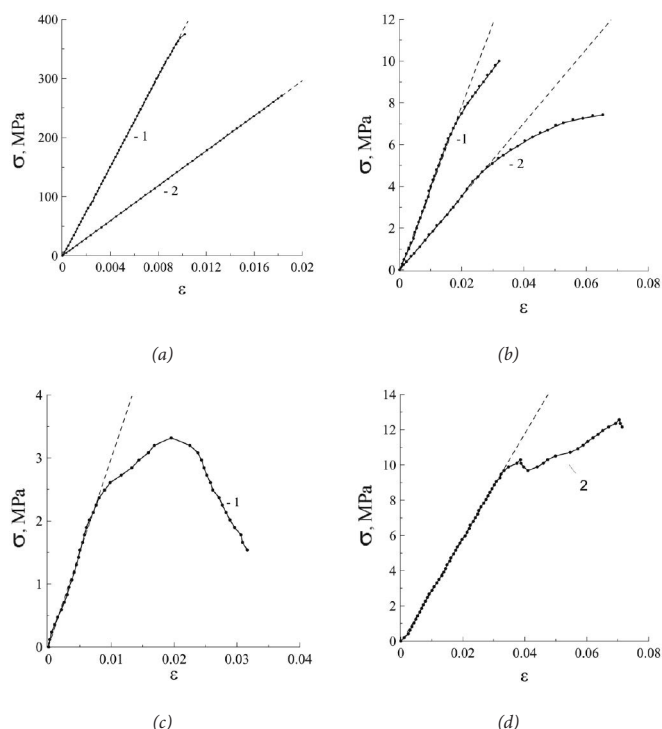

Fig. 2. Stress-strain diagrams obtained by tests in compression (curve 1) and shear (curve 2) for Al_2O_3 with porosity of: (a) - 20% (b) - 50%. (c) Stress-strain diagram obtained by tests in compression for alumina ceramics with a pore space volume over 60%. (d) Stress-strain diagram obtained by tests in shear for alumina ceramics with a pore space volume over 60%.

2. ábra A 20% (a) és 50% (b) porozitású Al_2O_3 kerámiák mért feszültség-deformáció diagramja nyomás (1 görbe) és nyírás (2 görbe) esetén; valamint a 60% porozitású kerámia feszültség-deformáció diagramja nyomás (c) és nyírás (d) esetén

Deformation diagrams of ceramics with porosity over 50% had a more complex behavior. The compression test curves mostly had a gradually descending stress arm (Fig. 2.c) which appear due to microdamages accumulated in the samples whereas the shear test curves had a slightly ascending arm after the stress fall curve portion which resulted from the stress growth (Fig. 2.d).

Observations of specimen structure after compression tests identified some differences in the nature of damage of ceramics with different porosities. In specimens with 18%-20% porosity, brittle fracturing of elastic specimens occurs after elastic energy accumulation. Due to elastic energy release, the specimen fully breaks down after reaching the compression strength limit. With a growth in pore space volume, damage of more localized nature is seen in ceramics and specimens do not fully break down after reaching the compression strength limit and, in general, do not lose the ability for future deformation. Specimens with a porosity near 40% after compression tests are shown in Fig. 3.a,b. It is visible that on the lateral surface of cylindrical specimens, cracks formed at a 45° angle to the applied load axis (Fig. 3.a). In such ceramics, a damage zone in the form of a truncated cone with a cone angle of about 45° forms after compression, while the cone basis lies almost in a static capture plane (Fig. 3.b). The deformation process of 50%-70% porous ceramics is accompanied with the appearance of multiple cracks directed primarily parallel to the loading axis (Fig. 3.c) on the lateral surface of the cylindrical specimen. In addition, the base

diameter of the cone forming in the deteriorating specimen was relatively smaller in size compared to denser ceramics (Fig. 3.b), while the cone's taper angle was approximately 45° (Fig. 3.d).

In the course of shear tests, specimens with $\leq 40\%$ porosity demonstrated the emergence of a main crack which was angled 45° towards the applied load (Fig. 3.e). The main crack appeared at the deformation stage right after the elastic part on the strain-deformation curve. In specimens with porosity over 40%, the deformation process was accompanied with the emergence of many fine cracks in different directions without the explicit main crack until the stage of complete destruction (Fig. 3.f). Fig. 3.b shows that on the edges of the specimen there are areas of material separated by developing cracks from the ceramic base, in which deformation from compression occurs.

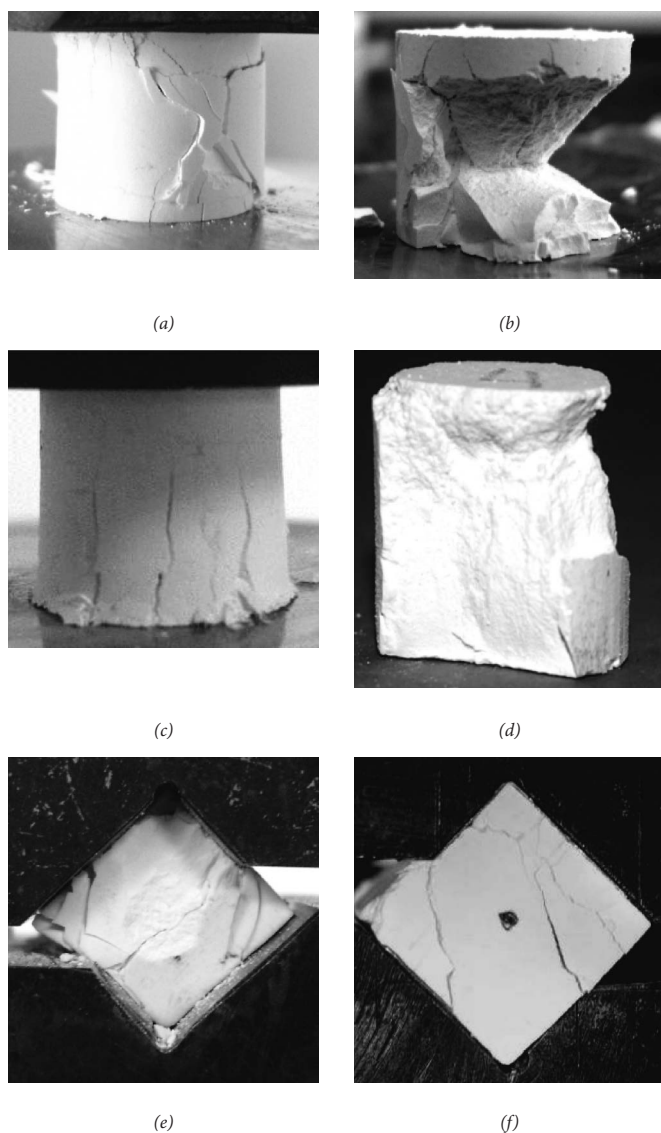

Fig. 3. The failure shape of Al_2O_3 specimens with porosities of: (a,b) 40%, (c,d) 55% after a test in compression. The failure shape of Al_2O_3 specimens with porosities of: (e) 40%; (f) 69% after a test in shear.

3. ábra A 40% (a, b), az 55% (c, d) porozitású Al_2O_3 próbatestek állapota nyomószilárdság vizsgálat után; illetve a 40% (e) és 69% (f) porozitású Al_2O_3 próbatestek a nyírószilárdság vizsgálat után

It is known that cracks appear at the location of deformation, in the most damaged areas of the material [11]. In the case when

stress is formed by an incline towards the compression of the damaged area, tension related to the presence of friction between the grip (plate) of the testing machine and adjacent ends of the sample plays a significant role in the failure [12]. Accordingly, the formation of cones inside of the collapsed samples (Fig. 3.c,d) due to the presence of friction forces and the destruction of ceramics under compression is controlled by shear stresses.

It is also known that the orientation of cracks depends on the accumulated strain limit value, or dilatancy (micro-crack saturation and their openings) [11]. As each pore is a potential source of microcracking in a porous material, and with the increase in the number of pores in a specimen, the number of such sources naturally grows, then the observable distinctions in the direction and behavior of crack spread in different porosity level ceramics (Fig. 3) are apparently the result of differing levels and natures of accumulated deformation in the form of microcracks that appear after compression and shear.

Studies of the mechanical and elastic properties of ceramics showed that within the studied intervals of pore space volume (from 0.18 to 0.72), the strength limit in compression and shearing, as well as the modulus of elasticity and shear modulus decrease with an increase in porosity (Fig. 4). In addition, the dependency of changes in strength properties on porosity is well-described by the law, and is near exponential.

As it is seen in Fig. 4.c, the absolute values of the modulus of elasticity and shear modulus grow closer with an increase in porosity, which shows a decrease in Poisson's ratio. It should be noted that in our case there is only a decrease in Poisson's ratio values. Determining the absolute values of Poisson's ratio in the process of mechanical testing was complicated, as experimental error constituted a value of ± 0.3 . An identification of Poisson's ratio by measuring the rate of longitudinal and latitudinal sound waves [13] in the ceramics performed with the use of an ultrasound flaw detector showed that values for Poisson's constant decreased from 0.21 to 0.15 with a growth in pore space volume of 20% to 40%.

The fact that Poisson's ratio decreases with an increase of pore space volume was previously noted in several publications [1, 13]. In [13, 14] it was shown that for porous isotropic bodies, the values of Poisson's ratio depend on the pore space volume, pore geometry and Poisson's ratio values for a pore-free material state (μ_0). For materials with $\mu_0 > 0.2$ (including alumina ceramics), it is theoretically predicted and experimentally proven that there is a decrease in the values of Poisson's ratio with an increase in pore space volume for ceramics with different pore geometry [13, 14].

The decrease of values for Poisson's ratio with an increase in pore space volume can be explained by nonlinear elasticity, which similar porous ceramics display under mechanical loading [15, 16]. Furthermore, local deformations due to relative movements and deformations of its structural components play an essential role in the deformation of objects with a similar complicated internal structure, noticeably changing the elastic properties of metals [1].

4. Conclusions

The analysis of stress-strain curves of porous alumina ceramics (within the porosity range of 18% to 70%) showed

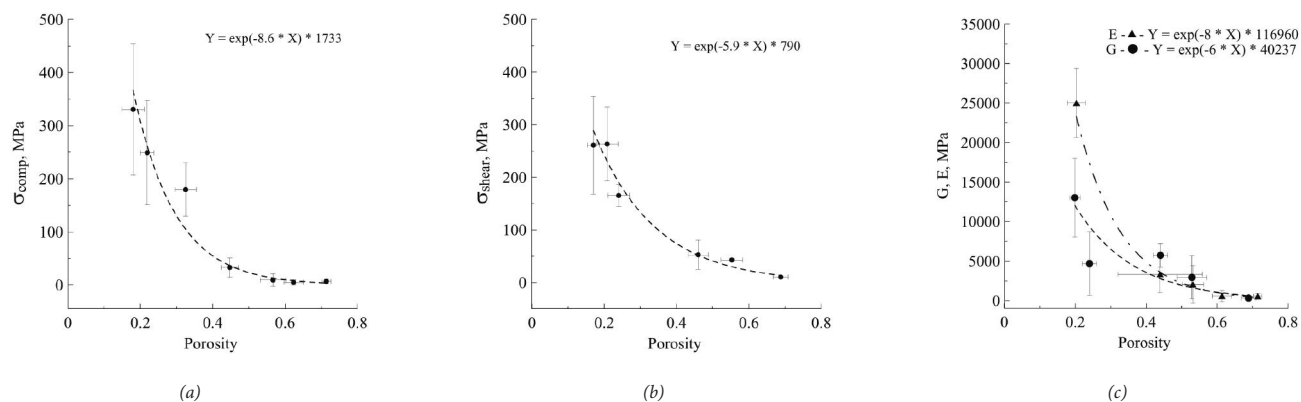

Fig. 4. Dependence of: (a) compressive strength, (b) shear strength, (c) modulus of elasticity and shear modulus values on pore space volume of alumina ceramics
4. ábra Alumínium-oxid kerámiák nyomó (a) és nyíró (b) szilárdsága, rugalmassági és nyírási modulusa (c) a pórustérfogat függvényében

that during deformation in compression and shear, there was a transition from a typically brittle state for relatively dense ceramics ($\leq 20\%$ porosity), to a pseudo-plastic state with a high porosity level (over 50%).

The values of the modulus of elasticity, shear modulus and Poisson's ratio all decrease with an increase in pore space volume of Al_2O_3 ceramics, which correlates with the appearance of multiple cracking in the course of the deformation of highly porous ceramics.

It was shown that during deformation in compression, the failure process was controlled by shear stresses, which leads to the formation of damage in the shape of cones in the internal volume of the specimen, the size and location of which depend on the pore space volume.

5. Acknowledgement

Part of this work is financially supported by Tomsk State University Competitiveness Improvement Program and Siberian Branch Program #III.23.2.3.

References

- [1] Ren, F. – Case, E. D. – Morrison, A. – Tafesse, M. – Baumann, M. J. : Resonant ultrasound spectroscopy measurement of Young's modulus, shear modulus and Poisson's ratio as a function of porosity for alumina and hydroxyapatite; (2009) *Philosophical Magazine*, v. 89/14, pp. 1163–1182
- [2] Gömze, László A. – Gömze, Ludmila N.: Advanced Hetero-Modulus and Hetero-Viscous Complex Materials; (2013) *Materials Science Forum*, v. 729, pp. 43–48
- [3] Kageyama, Kensuke – Harada, Youhei – Kato, Hiroshi: Preparation and Mechanical Properties of Alumina–Zirconia Composites with Agglomerated Structures Using Pre-Sintered Powder; (2003) *Materials Transactions*, v. 44, No. 8, pp. 1571–1576
- [4] Kurosawa, Shunsuke – Bispo, Lucas – Shoji, Yasuhiro – Seki, Mafuyu – Yokota, Yuui – Chubaci, Jose F. D. – Yoshikawa, Akira: TL Properties of Pure Al_2O_3 Grown by the Micro-Pulling down Method; (2014) *Key Engineering Materials* v. 616, pp. 87–91; <http://dx.doi.org/10.4028/www.scientific.net/KEM.616.87>
- [5] Fischer, H. – Marx, R.: Fracture toughness of dental ceramics: comparison of bending and indentation method; (2002) *Dental Materials*, v. 18, No. 1, pp. 12–19
- [6] Fernando, J. A. – Chung, D. D. L. : Thermomechanical properties of alumina fiber membrane; (2005) *Ceramics International*, v. 31, pp. 453–460, <http://dx.doi.org/10.1016/j.ceramint.2004.06.010>
- [7] Corrêa de Sá, Maria Cecilia – de Moraes, Benevides – Elias, Carlos Nelson – Filho, Jamil Duailibi – Guimarães de Oliveira, Leandra: Mechanical properties of alumina-zirconia composites for ceramic abutments; (2004) *Mat. Res.* v.7 No.4 São Carlos Oct./Dec. 2004

- [8] Kalatur, E. S. – Kozlova, A. V. – Buyakova, S. P. – Kulkov, S. N. : Deformation behavior of zirconia-based porous ceramics, (2013) *IOP Conf. Ser.: Mater. Sci. Eng.* 47 012004 <http://dx.doi.org/10.1088/1757-899X/47/1/012004>
- [9] Hakuta, Y. – Nagai, N. – Suzuki, Y. H. – Kodaira, T. – Bando, K. K. – Takashima, H. – Mizukami, F.: Preparation of α -alumina nanoparticles with various shapes via hydrothermal phase transformation under supercritical water conditions; (2013) *IOP Conf. Ser.: Mater. Sci. Eng.* 47 012045 <http://dx.doi.org/10.1088/1757-899X/47/1/012045>
- [10] Savchenko, N. L. – Sablina, T. Yu. – Poletika, T. M. – Artish, A. S. – Kulkov, S. N.: High-temperature sintering in vacuum of plasma-chemical powders based on ZrO_2 ; (1994) *Powder metallurgy*, No. 1–2, pp. 26–30.
- [11] Stefanov, Yu.P.: Modes of dilatancy and deformation development condensation in localized shear zones; (2010) *Physical mesomechanics*, v.13, Spec. Edition, p.44–52.
- [12] Goldshtein, R. V.: Damage under compression; (2003) *Mechanics advances*, v. 2, p. 3–17
- [13] Phani, K. K.: Correlation between ultrasonic shear wave velocity and Poisson's ratio for isotropic porous materials; (2008) *J. Mater. Sci.*, 43, pp 316–323
- [14] Dunn, Martin L. – Ledbetter, Hassel: Poisson's ratio of porous and microcracked solids: Theory and application to oxide superconductors; (1995) *Journal of Materials Research*, v. 10/11, pp 2715–2722
- [15] Kulkov, S. N. – Maslovskiy, V. I. – Buyakova, S. P. – Nikitin, D. S.: Non-Hookean behavior of porous zirconium dioxide under active compression deformation; (2002) *Technical physics journal*, v. 72/3, pp. 38–42
- [16] Kulkov, S. N. – Buyakova, S. P. – Maslovskiy, V. I.: Micromechanical instability under porous ceramic materials deformation (2004). *Physical mesomechanics*, 7, Spec. Edition. v. 1, pp. 131–134.

Ref.:

Savchenko, N. L. – Sevostyanova, I. N. – Sablina, T. Y. – Molnár, L. – Géber, R. – Gömze, L. A. – Kulkov, S. N. – Gömze, L. N.: *The Influence of Porosity on the Elasticity and Strength of Alumina Ceramics* Építőanyag – Journal of Silicate Based and Composite Materials, Vol. 66, No. 2 (2014), 44–47. p. <http://dx.doi.org/10.14382/epitoanyag-jsbcm.2014.9>

A porozitás hatása alumínium-oxid kerámiák szilárdságára és rugalmasságára

Jelen munkában a szerzők a 18%–70% porozitású alumínium-oxid kerámiák szilárdsági és deformációs tulajdonságait vizsgálják nyomó és nyíró feszültségek hatására. A vizsgálatok során kapott „feszültség-deformáció” görbék azt mutatják, hogy a nagy sűrűségű (porozitás $\leq 20\%$) tipikusan rideg Al_2O_3 kerámia a pórustérfogat arányának növelésével (50% felett) átalakul pseudo-plasztikus anyaggá. Ugyanakkor az alumínium-oxid kerámiák rugalmassági modulusa, nyírási modulusa és Poisson tényezője jelentős mértékben csökken a pórustérfogat arányának növekedésével.

Kulcsszavak: alumínium-oxid, deformáció, rugalmassági modulus, képlékenység, porozitás, nyírás, szilárdság, feszültség, fajlagos alakváltozás

Restructuring of Ceramics Features with Changes in the Large and Nanocrystalline Ceramic System Ratio

MIHAIL GRIGORIEV ▪ Tomsk State University (TSU), Tomsk (Russia) ▪ grv@ispms.tsc.ru

LÁSZLÓ A. GÖMZE ▪ University of Miskolc, Egyetemváros, Miskolc (Hungary) ▪ IGREX Engineering Service Ltd, Igrici (Hungary) ▪ femgomze@uni-miskolc.hu ▪ igrex2009@yandex.ru

SERGEY N. KULKOV ▪ Tomsk State University (TSU), Tomsk (Russia) ▪ Institute of Strength Physics and Materials Science SB RAS, Tomsk (Russia) ▪ grv@ispms.tsc.ru ▪ kulkov@ms.tsc.ru

Received: 28. 06. 2014. ▪ Érkezett: 2014. 06. 28. ▪ <http://dx.doi.org/10.14382/epitoanyag-jsbcm.2014.10>

Abstract

The structure and properties of ceramic based on alumina powders systems produced by the method of thermal decomposition of hydroxide aluminum and the plasma-spray pyrolysis method has been studied. It is shown that at the maintenance of 60 % plasma-chemical powder Al_2O_3 in mix sharp change strength characteristics which those more than have less porosity is observed. Approximation of strength dependence vs. average pore size to porousless state shows a possibility of obtaining material with almost theoretical strength. Correlation between microstresses in crystallites and macrostrength in sintered ceramics was found.

Keywords: alumina, ceramic powders, microstructure, nanocrystalline, plasma-spray, pyrolysis, strength, stress

1. Introduction

Using nano-sized ceramic powders which are not in equilibrium opens up entirely new opportunities to obtain highly porous ceramics [1-5]. Due to the developed surface of the nanocrystalline particles, special nanocrystalline structures are formed with a high bonding strength at the grain boundaries, providing high strength for the ceramics [6-8].

A promising method for creating permeable ceramic materials with high porosity is the mixing large-fractured and ultrafine powders [9], and the geometry of the pores obtained in such a way is determined by the size and shape of large-fractured powder particles [10]. However, when creating a porous ceramic material in this manner ultra-fine powder is used only as an additive (as a rule up to 10 %) [11], in other words, the pattern formation in ceramics porous structures with ultrafine powders, over a wide range of content, are not well understood. However, the data on the pore structure of those materials and its relation to the fine crystal structure parameters have a fundamental importance in the analysis of the deformation behavior [12, 13].

The aim of this paper is to investigate the crystal structure of the thin porous alumina ceramics synthesized from powders with different particle sizes (dispersion).

2. Materials and methods

To obtain porous ceramic mixture powders, mixtures of powder were prepared in a wide range from technical alumina (GOST 30558-98) to plasma chemical Al_2O_3 (TU -2320-001-07622928-96). Sintering is performed at temperatures of 1200, 1300, 1400, 1500, 1600 and 1650 ° C for duration in the isothermal hold of one hour.

X-ray diffraction analysis was performed on ceramics (DRON UM1) with filtered CuK α radiation. The average

Mihail V. Grigoriev, PhD

has finished the Polytechnical Institute of the Siberian Federal University in 2007. At present time he is a post-doctoral fellow in Institute of Strength Physics and Materials Science of Siberian Branch of the Russian Academy of Science under guidance Prof. Kulkov. Topic of his PhD. work was „Features of deformation and fracture of porous alumina ceramics based on nanopowders”.

Prof. Sergey N. Kulkov

Prof. Kulkov is head of Department of Ceramics in the Institute of Strength Physics and Materials Science of the Russian Academy of Science since 1989. He has got scientific degrees „Doctor of Physics and Mathematical Sciences” in 1990. Since 1992 he's working as professor both in Tomsk State University and in Tomsk Polytechnic University. In 1997 he had a Soros Professor grant. His research works are represented in 5 books, more than 150 articles, 18 patents and many International Symposiums and Conferences. At present he is head of department „Theory of Strength and Mechanic of Solids”, member of „The American Ceramic Society” of „The APMI - International” and the DYM AT Society (France).

Prof. László A. Gömze

Establisher (in July 1st, 1999) and head of Department of Ceramics and Silicate Engineering in the University of Miskolc, Hungary. Since then 7 students from the department have successfully completed their PhD theses and 4 of them were managed by Prof. Gömze. He is author or co-author of 2 patents, 5 books and more than 250 scientific papers. Recently, he is the chair of the International Organization Board of ic-cmtp³ the 3rd International Conference on Competitive Materials and Technological Processes (2014) and ic-rmm² the 2nd International Conference on Rheology and Modeling of Materials (2015).

crystallite size was calculated from the broadening of the reflex to small angles. The values of micro distortions crystal lattice were calculated from the broadening of the reflex to the far corners of the diffraction pattern.

Analysis of the morphology of the pore structure was carried out by scanning electron microscopy by QUANTA 200 3D microscope. The pore size was determined by random secants, the number of measurements was at least 300.

3. Results and discussion

Research was conducted on the polished surface of the ceramic samples sintered at 1650 ° C and holding 1:00 hour (Fig. 1). It was found that the pore structure of the commercial alumina sample is a system of continuous long channelization and disordered forms of dense portions corresponding to the alumina agglomerates, in which at higher magnification there can be seen varying forms of closed pores larger than 5 microns. In fact, this structure corresponds to two interpenetrating components: substance and pore.

In contrast to the ceramics consisting of industrial alumina, the pore structure of the plasma-chemical sample Al_2O_3 powder represented as mainly isolated pores with a random pore shape and distinct clusters of various sizes (Fig. 2). Mostly, the amount of isolated pores had a size of less than 2 microns. The average pore size of the clusters was 10 microns.

In the studied ceramics, bimodal distribution of pore size is observed. The first maximum (d1) is due to pores in size less

than 5 microns, the size of which is commensurate with the size of grains. A second maximum (d_2) forms macropores ranging in size from 5 to 100 microns. Such large voids in ceramics are due to the formation of lasting frameworks made of used agglomerates powders during pressing, the dimensions of which determine the size of macropores between them. In coarse fraction ceramic powder, the ratio of pore size of 0.5 microns is substantially lower than the ceramic powders of the nanocrystalline plasmochemical Al_2O_3 .

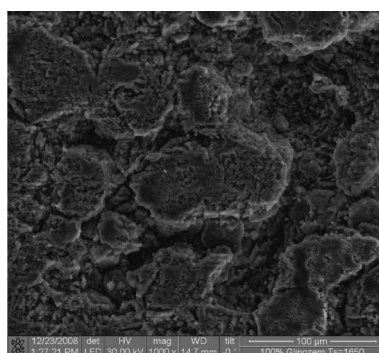

(a)

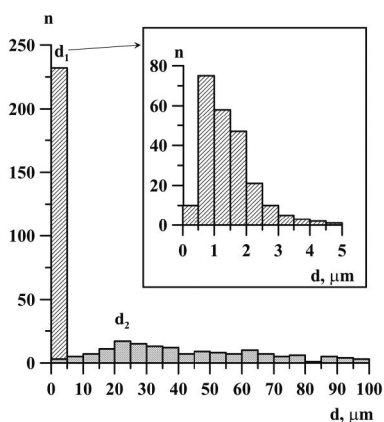

(b)

Fig. 1. The microstructure (A) and pore size distribution (B) for industrial ceramics based on alumina, sintered at 1650 °C and holding for 1 hour.

1. ábra Az 1650 °C-on 1 órán át szinterezett alumínium-oxid alapú ipari kerámiák mikroszerkezete (A) és pórusméret-eloszlása (B)

With the increase of the content of plasma chemical powder in the starting mixture the communicating pore space starts to decrease, and thus, the reduction in the size of channelization is considerable. This is evidenced by reduction of the average pore size from 53 to 9 microns for maximum d_2 . However, in ceramics that contains only plasmochemical powder, the porosity is again increasing. In ceramics containing 90% plasma chemical powder, the densest structure occurs, and there are isolated pores with random shapes and pores separate clusters. Apparently, this is due to the fact that the alumina 10% additive added to the plasma chemical Al_2O_3 powder destroys the foam-like agglomerates plasma chemical powder on the pressing stage, wherein the particles and agglomerates of industrial alumina are not enough to form a lasting framework on their base.

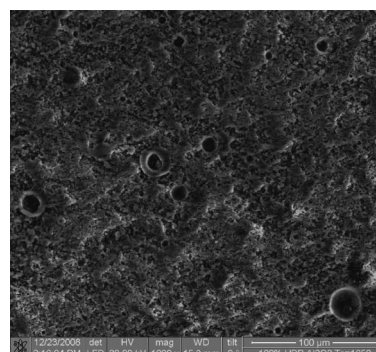

(a)

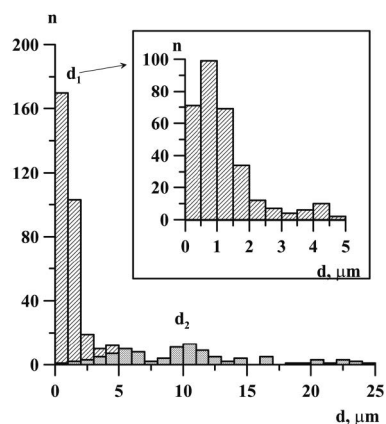

(b)

Fig. 2. Microstructure (A) and pore size distribution (B) for plasma-chemical based ceramic powder Al_2O_3 , sintered at 1650 °C and holding for 1 hour.

2. ábra A plazma-kémiai eljárással előállított porból készített és 1650 °C-on 1 órán át szinterezett Al_2O_3 kerámia próbatetek mikroszerkezete (A) és pórusméret-eloszlása (B)

Research on the influence of the crystallite size on micro distortions crystal lattice showed that the latter decreases with the increase of crystallite D (Fig. 3). Built dependence is described by the following formula:

$$\langle \varepsilon^2 \rangle^{1/2} = 3.4 \cdot D^{-0.6} \quad (1)$$

The case when $\langle \varepsilon^2 \rangle^{1/2} \sim D^{-1}$ proves that the main contribution to micro distortions lattice in the studied ceramics is made by the interfaces, which are always present in such systems. In this regard, the smaller are the crystallites, i.e. the length of the border, the higher is the level of micro distortions.

The relationship was investigated between the fine crystal structure parameters and the sintering temperature, which indicates that, with an increase in the sintering temperature, the average crystallite size increases linearly, and the level of the crystal microstrains lattice decreases.

An estimation was made for the diffusion activation energy, which is equal to $97 \cdot 10^3$ J/mol or 23 kcal/mol, which is 5 times less than the activation energy of self-diffusion of aluminum and oxygen in polycrystalline oxide, from which we may suggest that the main mechanism of mass transfer during sintering is grain boundary diffusion.

We found that the increase in porosity is accompanied with a decrease in crystallite size and microstrain growth. Dependence of crystal lattice micro distortions porosity in alumina ceramics has a pronounced kink in the porosity of about 50% (Fig. 4).

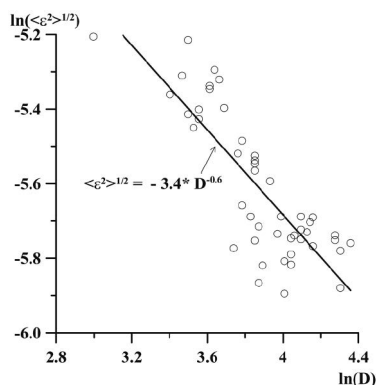

Fig. 3. Dependence of the average level of micron-sized crystallites in alumina ceramics made from powders with different particles.
 3. ábra Az alumínium-oxid kerámiákban szinterezéskor kialakuló kristály-méreték függése a gyártáshoz használt porok szemcseméretétől.

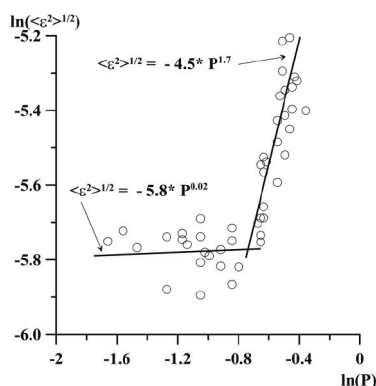

Fig. 4. Micro distortions crystal lattice dependence on the porosity in the studied ceramics.
 4. ábra A vizsgált kerámiákban a kristályrács mikro-torzulásainak függése a porozitástól

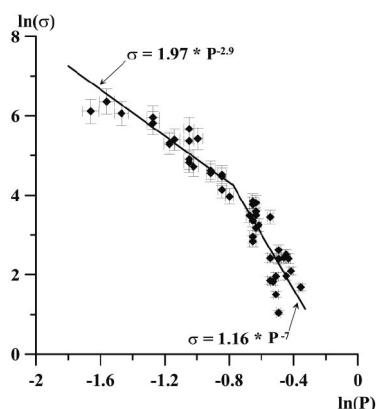

Fig. 5. The compressive strength dependence on the porosity of the ceramic-based powders with different particle sizes.
 5. ábra A különböző szemcseméretű porokból készített készült kerámia próbatestek nyomószilárdságának függése az átlagos pórusátméretétől

Investigation of the effect of porosity on the strength of the ceramic showed that the strength of the samples decreases significantly with increasing porosity, when porosity is in the range of about 50%, the angle of inclination of the approximating line is changed (Fig. 5). Primarily, it is due to the fact that there is a change in the nature from the isolated pores structure and pore clusters of various shapes and sizes for a ceramics structure consisting of two interpenetrating component, i.e. substance and pore.

Thus, the changing of the pore structure nature is accompanied with a sharp decrease in the strength and growth of the crystal lattice microstrain, which corresponds to the percolation transition in the ceramics under examination.

Type pore volume and pore size also significantly affect the strength of the material. It was found that the tensile strength is greater, the smaller the average pore size and dispersion, and the extrapolation of this dependence to zero porosity showed that the strength of the studied ceramics will be about 3.5 GPa, which corresponds to the estimated strength of alumina that is available in the literature [14, 15].

4. Conclusions

It was found that in the ceramic-based powders with different particle pore structures, the change in the nature of the ceramic frame and the large pore space to isolated pores and pore clusters coincides with the increase of the nanocrystalline powder in the initial mixture of powders.

Pore structure type changes with a porosity of about 50% and is accompanied with a sharp decrease in strength and a decrease in microstrain, which corresponds to the percolation transition in the ceramics under examination.

Pore size distribution is bimodal. The first maximum is due to pore size of less than 5 microns, the second is a pore size of 5 to 100 microns.

The estimation of the activation energy of the grain growth process during sintering is 23 kcal/mol. This value is showing that the main mechanism of sintering is grain-boundary diffusion.

The determined relationship between crystallite size and crystal lattice micro distortions indicates that the examined ceramics' main defect part is located at the grain boundaries.

Thus, the obtained results enable a directional adjusting of the structure and properties of ceramic materials based on aluminium oxide powders with different particle sizes. This makes possible to practically obtain a variety of structures either as highly porous and substantially zero porosity with a set complex of physical and mechanical properties.

5. Acknowledgement

Part of this work is financially supported by Tomsk State University Competitiveness Improvement Program and Siberian Branch Program #III.23.2.3.

References

- [1] Kulkov, S. N. – Grigoriev, M. V.: Sintering of Al₂O₃ ceramics based on different sizes powders, (2010), *Építőanyag*, Vol. 61, No. 3, pp. 34-38; <http://dx.doi.org/10.14382/epitoanyag-jsbcm.2010.3>
- [2] Kamitani, Kazutaka – Hyodo, Takeo – Shimizu, Yasuhiro – Egashira, Makoto: Fabrication of Highly Porous Alumina-Based Ceramics with Connected Spaces by Employing PMMA Microspheres as a Template; (2009) *Advances in Materials Science and Engineering*, <http://dx.doi.org/10.1155/2009/601850>
- [3] Okada, Kiyoshi et al: Porous ceramics mimicking nature – preparation and properties of microstructures with unidirectionally oriented pores; (2011) *Sci. Technol. of Adv. Mater.*, Vol. 12, <http://dx.doi.org/10.1088/1468-6996/12/6/064701>
- [4] Isobe, T. – Kameshima, Y. – Nakajima, A. – Okada K., K. – Hotta, Y.: Preparation and properties of porous alumina ceramics with oriented cylindrical pores produced by an extrusion method; (2006) *J. Eur. Ceram. Soc.*, Vol. 26, No. 6, pp. 857-960

- [5] T. Isobe, – Y. Kameshima Y, – A. Nakajima, – K. Okada – Y. Hotta: Gas permeability and mechanical properties of porous alumina ceramics with unidirectionally aligned pores; (2007) *J. Eur. Ceram. Soc.*, Vol. 27. No. 1, pp. 53-59
- [6] Buyakova, S. P. – Kulkov, S. N.: Formation of the structure of porous ceramics sintered from nanocrystalline powders; (2005) *Refractories and technical ceramics* № 11, pp. 6-11
- [7] Gömze, László A. – Gömze, Ludmila N.: Alumina based hetero-modulus ceramic composites with extreme dynamic strength; (2009) *Építőanyag*, Vol. 61, No. 2, pp. 38-42
<http://dx.doi.org/10.14382/epitoanyag-jsbcm.2009.7>
- [8] Chen, X. – Chadwick, T. C. – Wilson, R. M. – Hill, R. – Cattell, M. J.: Crystallization of High-strength Fine-sized Leucite Glass-ceramics, (2010) *Journal of Dental Research*, Vol. 89. pp: 1510-1516
- [9] Tomilina, E. – Pronin, O. – Lukin, E. – Kagrananov, G. : Porous ceramics based on alumina; (2000) *Glass and ceramics*, No. 6, pp. 23-24
- [10] Salihov, T. – Kahn, V. – Urazaeva, E. at all: Alumina ceramics filter on phosphate bonds; (2008) *Glass and ceramics*, No. 8, pp. 28-31
- [11] Krasniy, B. at all: Properties of porous permeable ceramic powders based on mono-fractioned corundum and nano-disperse binder; (2009) *Glass and ceramics*, No. 6. pp. 18-21
- [12] Miranda-Hernandez, J. G. – De La Torre, S. Diaz – Rocha-Rangel, E. : Synthesis, microstructural analysis and mechanical properties of alumina-matrix cermets; (2010) *Építőanyag* Vol. 62/1, pp. 2-5;
<http://dx.doi.org/10.14382/epitoanyag-jsbcm.2010.1>
- [13] Kaygorodov, A. – Khrustov, V. : The influence of Al_2O_3 + Al powders stirring time on the quality of alumina based ceramics (2010) *Építőanyag*, Vol. 62, No. 4, pp. 102-106;
<http://dx.doi.org/10.14382/epitoanyag-jsbcm.2010.21>
- [14] Andrievskii, R. – Spivak, I.: Strength of refractory compounds and materials based on them; (1989) *Chelyabinsk Metallurgy*, pp. 250-251
- [15] Zhou, Li-Zhong – Wang, Chang-An – Liu, Wei-Yuan: Fabrication of Low Density High Strength Porous Mullite Ceramics by Tert-butyl Alcohol-based Gelcasting Process, (2009) *Journal of Inorganic Materials*, No. 01
<http://dx.doi.org/10.3724/SP.J.1077.2009.01173>

Ref.:

Grigoriev, M. – Gömze, L. A. – Kulkov, S. N.: *Restructuring of Ceramics Features with Changes in the Large and Nanocrystalline Ceramic System Ratio*
Építőanyag – Journal of Silicate Based and Composite Materials, Vol. 66, No. 2 (2014), 48–51. p.
<http://dx.doi.org/10.14382/epitoanyag-jsbcm.2014.10>

Szerkezet-átalakulások és viselkedésbeli változások a nagy- és nanokristályos kerámia rendszerekben

A szerzők az alumínium-hidroxid termikus bomlásával és a plazmaszórásos pirolízis módszerével előállított porokból készített alumínium-oxid kerámiák mikroszerkezetét és tulajdonságait vizsgálták. Az eredmények azt mutatják, hogy a 60% plazma kémiai úton előállított Al_2O_3 port tartalmazó keverékből készült kerámiák mechanikai szilárdsága ugrásszerűen megnő, míg a szinterezéskor kialakuló pórusok mérete jelentősen lecsökken. Azzal, hogy a pórusátmérők csökkenésével arányosan nő az alumínium-oxid kerámiák mechanikai szilárdsága, lehetőség nyílik az elméleti mechanikai szilárdság elérésére – illetve megközelítésére. A szerzők feltárták a kristallitok mikroszilárdsága és a szinterelt kerámiák makroszilárdsága közötti korrelációt.

Kulcsszavak: alumínium-oxid, feszültség, kerámia porok, mikroszerkezet, nanokristály, pirolízis plazmaszórás, szilárdság

The Perlite Institute

The Perlite Institute was founded in 1949, a year in which it is estimated only 80,000 tons of perlite ore was mined throughout the world. The unusual properties and advantages of this virtually new material had been known for some time, yet recognition and acceptance was impeded due to a lack of reliable technical data, uniform commercial standards and sufficient public information.

What was needed was a coordinated effort, a continuing campaign to secure the future of the perlite industry—an industry of highly promising but largely unexploited potential. Miners of perlite ore and perlite expanders combined efforts and resources in order to help themselves individually. The Perlite Institute was founded.

Its most important task was to develop, through approved investigation and research, a greater technical and engineering knowledge of perlite and then to disseminate the information to its members, architects, engineers, landscapers and other users of the product. The Institute's goal was to increase the public's awareness and knowledge of perlite through well-organized and effective programs of publicity and advertising. It would provide a forum for discussing common problems and creating solutions through cooperative thinking and effort. It would assist the perlite producer in marketing, sales promotion and sales training.

Perlite in Construction

Perlite is a versatile and sustainable mineral that is mined and processed with a negligible impact on the environment. And the green community recognizes perlite-enhanced products—like lightweight insulating concrete roof decks—as a high-performance solutions drawn from a natural material of nearly unlimited supply throughout the world.

Research suggests that more than 50 percent of expanded perlite worldwide is used by the construction industry. Perlite plays an important role in a wide variety of construction-related uses including: as an aggregate in lightweight insulating concrete and plaster; as a loose fill insulation material for concrete masonry blocks, cavity walls, in residential homes; and in a variety of specialty applications including fireproofing sprays, chimney fills, interstitial floors, acoustical sprays, etc.



Perlite Institute, Inc.
www.perlite.org • (717) 238-9723

Copyright © 2009 Perlite Institute All Rights Reserved

Optimization of ceramic manufacturing process using Plackett-Burman design of experiment

ÁDÁM EGÉSZ • Department of Ceramics and Silicate Engineering, University of Miskolc, Miskolc, (Hungary) • GE Hungary Ltd., Budapest, (Hungary) • adam.egesz@ge.com

SVETLANA P. BUYAKOVA • sbuyakova@ispms.tsc.ru

SERGEY N. KULKOV • kulkov@ispms.tsc.ru

LÁSZLÓ A GÖMZE • Department of Ceramics and Silicate Engineering, University of Miskolc, Miskolc, (Hungary) • femgomze@uni-miskolc.hu

Received: 28. 06. 2014. • Érkezett: 2014. 06. 28. • <http://dx.doi.org/10.14382/epitoanyag-jsbcm.2014.11>

Abstract

In this research, the authors describe the ceramic injection molding process, and its most important features. Using the method of design of experiment, the connection was discovered between the adjustable machine parameters and the quality of end product, especially highlighted the cracks in the ceramic body. The researchers found as main result, that the machine settings have more impact on the quality of end product, than the applied mold temperatures during injection molding. Furthermore, the holding pressure had the highest impact on the weight of end product, the weight increased with the holding pressure according to a linear relationship.

Keywords: alumina powder, ceramic injection molding, design of experiment, feedstock, paraffin wax

1. Introduction

The sophisticated ceramic, plastic and powder metallurgy industries and technologies require higher and higher demands against quality, volume and yield of end product [1, 2]. In the illuminant industry, for producing arc tube parts for high intensity discharge lamps the applied method is the ceramic injection molding. For producing ceramic arc tube parts (plugs), two different major components are used for producing injection molding raw material (hereinafter: feedstock): high purity alumina powder as the main component, and an organic paraffin wax as binder material. For producing the injection molding feedstock, the wax binder is melted in a sigma-blade mixer, and the alumina powder is sequentially mixed to the wax after it was melted. The properly mixed material is cooled down to room temperature, and - depending on the injection molding machine - it is granulated or crushed with jaw crusher. The fine tuning of the manufacturing process, the determination and controlling of the influential parameters have an outstanding importance on the production of high quality end product. Nevertheless, before any optimization of the feedstock preparation process, it is needed to know, determine and control the parameters of injection molding process. We can optimize the raw material only using a stabile, robust, properly adjusted injection molding machine, and therefore, the material properties and the producing process will be set for this optimized injection molding process, to decrease the amount of cracked ceramics [3-5]. Namely, in the present case, the output parameter eventually will be the injection molded, sintered parts, and their quality, and if the different materials are tested using a non-optimized injection molding process, then the injection molding will be only noise factor in the material experiments [6].

1.1. The properties of applied injection molding machine

The experimental ceramic parts (plugs) (Fig. 1) were made on full electronic injection molding machine with different settings.

Ádám EGÉSZ

Graduated in the University of Miskolc, Department of Ceramics and Silicate Engineering as a material engineer, where he actually continues his study as PhD student. In addition, currently he works for the GE Lighting as a project engineer, where he optimizes the manufacturing process of ceramic production for high intensity discharge lamps, especially the injection molding and its raw material. During his studies, he prepared several award-winning TDK papers.

Prof. Svetlana P. BUYAKOVA

Doctor of Sciences from 2008, full Professor from 2013. She is specialist in material sciences of ceramics and ceramic matrix composites based on oxides and carbides. She is author and co-author of more than 100 papers. Three Ph.D. students and one person makes they dissertations under her guidance in period 2010-2013. Now, she is chief scientist in IS PMS RAS and professor in Tomsk State University and Tomsk Polytechnic University. Her teaching experience: Introduction to Materials Science, Fundamentals of Materials Engineering, Materials and their Applications.

Prof. Sergey N. Kulkov

Prof. Kulkov is head of Department of Ceramics in the Institute of Strength Physics and Materials Science of the Russian Academy of Science since 1989. He has got scientific degrees „Doctor of Physics and Mathematical Sciences” in 1990. Since 1992 he’s working as professor both in Tomsk State University and in Tomsk Polytechnic University. In 1997 he had a Soros Professor grant. His research works are represented in 5 books, more than 150 articles, 18 patents and many International Symposiums and Conferences. At present he is head of department „Theory of Strength and Mechanic of Solids”, member of „The American Ceramic Society” of „The APMI - International” and the DYM AT Society (France).

Prof. László A. Gömze

Establisher (in July 1st, 1999) and head of Department of Ceramics and Silicate Engineering in the University of Miskolc, Hungary. Since then 7 students from the department have successfully completed their PhD theses and 4 of them were managed by Prof. Gömze. He is author or co-author of 2 patents, 5 books and more than 250 scientific papers. Recently, he is the chair of the International Organization Board of ic-cmtp³ the 3rd International Conference on Competitive Materials and Technological Processes (2014) and ic-rmm² the 2nd International Conference on Rheology and Modeling of Materials (2015).

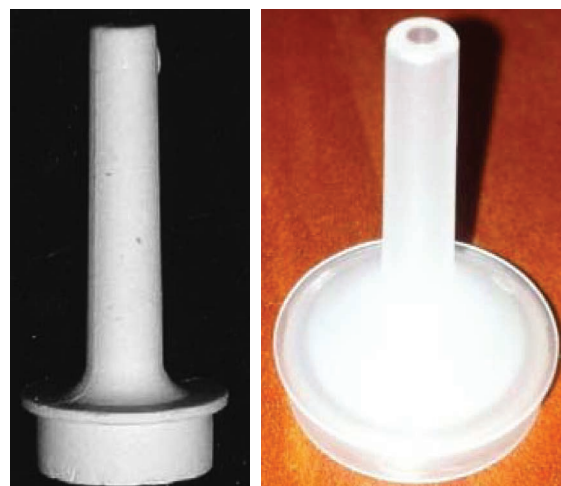

Fig. 1. Injection molded green part (a) and end product (b)
1. ábra Fröccsöntött nyers darab (a) és késztermék (b)

During molding, five external heating units can provide the proper temperature in the different parts of the mold: 2 heating units heat the hot side of the mold (manifold, tip), 2 units heat the cold side of the mold (side action and plug), and 1 unit heats the metering zone (barrel). Besides that, the machine is equipped with electronic nozzle heat (Fig. 2).

Since the machine is fully electronic, therefore it is well adjustable, and absolutely appropriate and usable for experimental purpose.

The elements and run order of an injection molding cycle can be seen in Fig. 3.

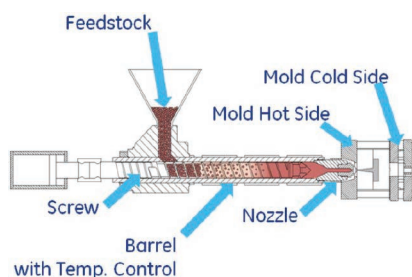

Fig. 2. The structure of injection molding machine
2. ábra A fröccsöntő berendezés szerkezeti felépítése

1.2. Injection

During injection the screw linearly moves forward like a piston, and pushes material into the mold. During the process a closing ring under the screw tip ensures the material to flow into the mold, and not move backward in the barrel. During the injection phase 95-99% of the material of end product is added into the cavities [7-10].

The injection phase ends with reaching the switching point, which switch in the holding pressure section.

1.3. Holding pressure / Holding time

The injection phase is followed by the holding pressure phase. During the holding pressure phase the screw slightly moves forward with very low speed, since the mold cavity is almost full of material during the injection molding phase. The holding pressure gives the material, which fully load the mold cavity and complements the material loss from volume reduction due to the cooling of the part [11-14].

During the holding pressure phase, the control of the movement of the screw is provided by pressure values, and not by velocity, like in the injection section.

The holding time is the duration of holding pressure.

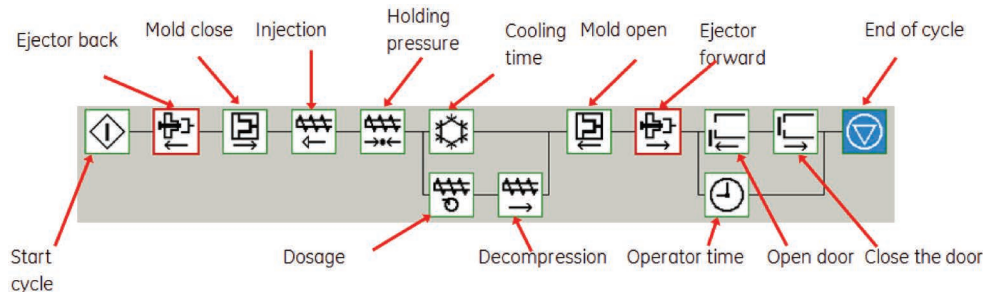

Fig. 3. Cycle diagram of injection molding
3. ábra Egy fröccsöntési ciklus folyamatabrája

1.4. Dosage

After the holding pressure phase the screw starts to rotate and carries material forward. In front of the screw, the accumulated material pushes the screw backward. The duration of this phase is the time until the screw reaches the prescribed dosage length (material amount) in front of the screw.

The main parameters of the phase are the back pressure and the peripheral speed of the rotating screw (dosage speed).

The dosage speed should be kept low, since higher speed multiplies the wear rate of the screw. If the dosage speed is higher than necessary, the feedstock can be heated up, what is also harmful on the condition of the machine [15].

1.5. Back pressure

In the case of electric machines, the back pressure means the pressure, which holds against the accumulated material, which is in front of the screw, and which tries to push the screw backward during the dosage. If the back pressure is too low, the material in front of the screw can not be tight enough, and can be airy during the injection. If the back pressure is too high, the feedstock can be heated up, or due to the too high pressure, the screw can not load the material in the barrel [16].

1.6. Decompression

After the dosage phase the screw shortly and linearly moves backward; this is the decompression phase. The role of this phase is to decrease the pressure in the material after the back pressure. If the pressure is too high after the dosage phase, due to the back pressure, the material flows out from the hot side of the mold after the opening of the mold. The duration of this phase is the decompression path length [17].

2. Experimental

2.1. Plackett-Burman screening design with 10 factors (DoE)

The name „Screening Design” refers to a design of experiment, which can select some significant factors from a higher amount of factors, considered potentially adjustable factors.

Alternatively, if the main goal of a design is the identification of the main effects, regardless to the different interactions (which has probably lower magnitude), this design is called also Screening Design.

If one has initially numerous factors, firstly it is expedient to perform a screening design, even if the final goal is the finding of a total output surface [18].

Typically, the screening design is a 3 level resolution design. This is very important, because the 3 level design can very effectively identify the main effects alias free, with low number of experiments.

2.2. The aim and implementation of experiment

As aim of experiment, it was intended to show the most important adjustable parameters of the injection molding machine, which have the highest effect on the yield and the occurrence of cracked parts.

In the experiment, 10 different factors were investigated on 2 levels, with 15 runs. This means III. level resolution, i.e. the main effects are mixed with second level interactions [19]. There were 3 repeated cells as a part of the design to check the linearity and repeatability.

Every cell consisted of 333 parts. The performance of injection molding was continuous, with the same operator, raw material and molding tool. After the injection molding, the sintered parts were examined.

The investigated outputs (answers) of the experiment were the following:

- the amount (ratio) of cracked parts, yield [%]
- the weight of green parts [g]

In this research, the Minitab software helped to prepare the design of experiment and its evaluation process.

Based on the engineering point of view, earlier experience and literature [20] research the initially tested factors are shown in Table 1.

Factor	Unit	Factor	Unit
1 Injections speed	mm/s	6 Dosage speed	m/min
2 Holding pressure	bar	7 Nozzle temperature	°C
3 Holdinh time	s	8 Barrel temperature	°C
4 Switching point	mm	9 Mold cold side temperature	°C
5 Back pressure	bar	10 Mold hot side temperature	°C

Table 1. Tested factors
1. táblázat A vizsgált faktorok

In Minitab software, in the yield-related analysis is better to use the transformed yield [21] instead of the good/all parts ratio, which is shown in eq. (1):

$$Yield_{Transz} = \frac{100}{90} \cdot ASIN \left(\sqrt{\frac{Good\ parts}{All\ parts}} \right) \quad (1)$$

The transformed yield can approach the normal distribution, thus the results can be analysed more effective using the usual Minitab evaluation tools [22].

3. Results and discussion

Investigating the transformed yield of the parts, the following statements can be taken:

It can be observed on the Pareto chart of main effects (Fig. 4), that all main factors have significant effect on the transformed yield, except the nozzle temperature. The Pareto chart also gives an order by the level of the different effects. The most important 4 factors are the back pressure, holding pressure, injection speed and holding time.

The main effect plot (Fig. 5) shows, that which directions of factors have effect on the increasing of good end parts [23]. Based on Fig. 5, the low level of injection speed, the high level of the holding pressure, holding time and back pressure are favorable in the low crack amount point of view.

On the main effect plot (Fig. 5), the average yields of center points are indicated by the blue dots. Based on the data of center points, one can determine a strong non-linearity. By evaluation of results, it is important to highlight, that the perspicacity was made more difficult by the non-linearity and the low resolution

of the experiment, due to the mixing of main and secondary interactions [24].

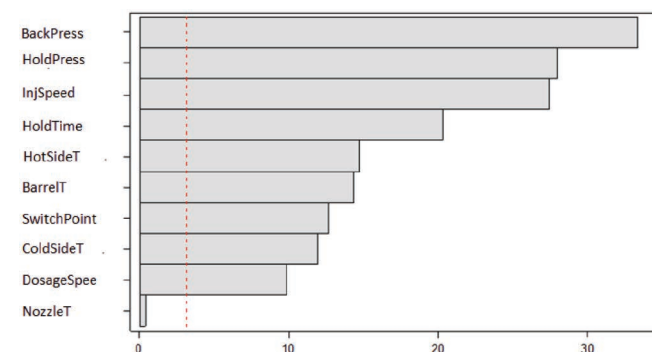

Fig. 4. Pareto chart of main effects
4. ábra A főhatások Pareto-ábrája

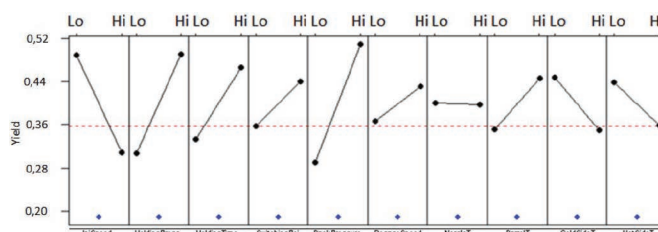

Fig. 5. Main effect plot
5. ábra Főhatás ábra

Summary of the experimentally found settings for the different machine factors can be seen in Table 2.

Screeninbest	
Back pressure	High
Holding pressure	High
Injection speed	Low
Holding tome	High
Switching point	Medium
Dosage speed	High
Cold side temp.	Low
Hot side temp.	Medium
Barrel temp.	High
Nozzle temp.	Medium

Table 2. Experimental settings, the optimal level of factors
2. táblázat A kísérleti beállítások és a faktorok optimális szintjei

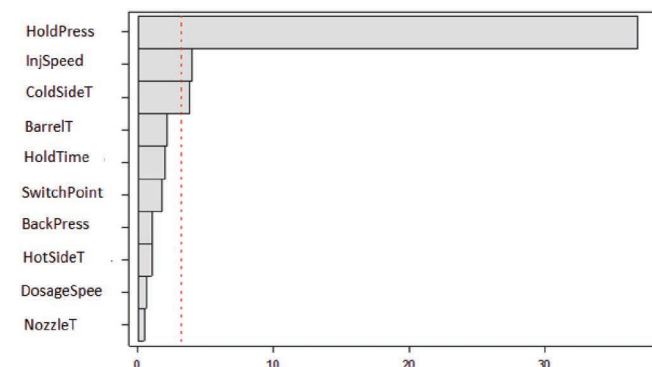

Fig. 6. Pareto chart of main effects for green part weight
6. ábra A nyers termék tömegére vonatkozó Pareto-ábra

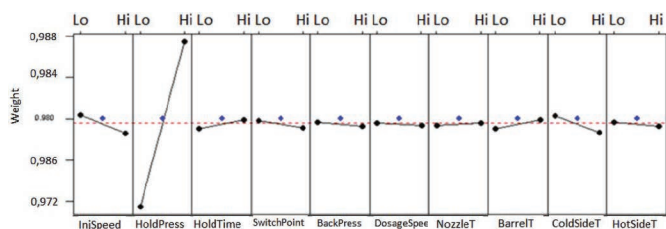

Fig. 7. Main effect plot of factors for the green part weight
7. ábra A nyers termék tömegére vonatkozó főhatás-ábra

Observing the average weight related Pareto chart (Fig. 6) one can establish, that the value of holding pressure is the most significant factor for this output. On the main effect plot it can be seen, (Fig. 7) that higher holding pressure resulted higher green product weight, and the connection between these two parameters is approximately linear in the investigated range.

4. Conclusions

According to the results of literature research, the prepared experiments and the present observations, the following considerations can be taken:

The method of design of experiment is especially suitable for optimizing a given injection molding process, and the optimal setting for a given end product can be found. It was seen, that using the multi-factor Plackett-Burman Screening design, the less important factors could be safely filtered, and the optimal settings could be found.

According to the experiments it was established, that the machine settings have more impact on the quality of end product than the applied mold temperatures during injection molding.

The holding pressure had the highest impact on the weight of end product, the weight increased with the holding pressure according to a linear relationship.

References

- [1] Emri, I. – Prodan, T.: Measuring system for bulk characterization of polymers. *Experimental Mechanics*, Vol. 46, No. 4., pp.429-439, 2006
<http://dx.doi.org/10.1007/s11340-006-8528-4>
- [2] Florjancic, U. – Zupancic, B. – Emri, I.: The effect of processing conditions on the durability of polymer products. *Int. J. Microstructure and Materials Properties*, Vol. 4., pp. 576-593, 2009
<http://dx.doi.org/10.1504/IJMMP.2009.031592>
- [3] Piotter, V. – Gietzelt, T. – Merz, L.: Micro powder-injection moulding of metals and ceramics. *Sadhana*, Vol. 28, Parts 1 & 2, 2003
<http://www.ias.ac.in/sadhana/Pdf/2003Apr/Pe1066.pdf>
- [4] Piotter, V. – Plewa, K. – Prokop, J. – Ruh, A.: Manufacturing of Versatile Ceramic or Metal Micro Components by PowderInjection Moulding. *Proc. of the 4th Internat. Conf. on Multi-Material MicroManufacture*, Cardiff, 2008
- [5] Piotter, V. – Mueller, T. – Plewa, K. – Prokop, J.: Manufacturing of complex-shaped ceramic components by micropowder injectionmolding. *The International Journal of Advanced Manufacturing Technology*, 2010
<http://dx.doi.org/10.1007/s00170-009-2095-7>
- [6] Rak, Z. S.: New trends in powder injection moulding. *Powder Metallurgy and MetalCeramics*, Volume 38, Numbers 3-4, 1999
<http://dx.doi.org/10.1007/BF02676037>
- [7] Wei, W. C. J. – Wu, R. Y. – Ho, S. J.: Effects of pressure parameters on alumina made by powder injection moulding. *Journal of the European Ceramic Society*, Volume 20, Issue9, 2000
[http://dx.doi.org/10.1016/S0955-2219\(99\)00295-2](http://dx.doi.org/10.1016/S0955-2219(99)00295-2)

- [8] Zlatkov, B. S. – Mitrovic, N. S. – Nikolic, M. V.: Properties of MnZn ferrites prepared by powder injectionmolding technology. *Materials Science and Engineering*, 2010
<http://dx.doi.org/10.1016/j.mseb.2010.07.031>
- [9] Mutsuddy, B. C.: Equipment selection for injection moulding. *Ceram. Bull.* 68,10, 1989
- [10] Emri, I.: The role of pressure in the behavior of time-dependent Materials. *in Recent Advances in Experimental Mechanics*, Edited by E.E. Gdoutos, pp. 19-30, Kluwer Academic Publisher, the Netherlands, 2002
- [11] German, R. M.: Global research and development in powder injection moulding, *Powder Injection Moulding International 1*, 2007
- [12] German, R. M.: Divergences in global powder injection moulding; *Powder InjectionMoulding International 2*, 2008
- [13] Maetzig, M.: Strategies for injection moulding metals and ceramics. *In: Proceedings of the 2002 World congress on Powder Metallurgy & Particulate Materials*, Orlando, Florida, 2002
- [14] Lenk, R.: Hot Moulding 2 An Interesting Forming Process, *cfi, Ber. Dtsch. Keram. Ges.*, 72, 10, 1995
<http://publica.fraunhofer.de/dokumente/PX-17497.html>
- [15] Verpoort, P. J.: Overview of powder injection moulding, *Advanced performancematerials*, 3, 2, 1996
- [16] Ballard, C.: Ceramic injection moulding meets the demand for manufacturing complexshapes, *Ceramic Industry 147*, 1997
- [17] Wroblewska, G. H.: Structural ceramics with complex shape – forming methods, *Ceramic Engineering and Science Proceedings*, 22, 2001
<http://dx.doi.org/10.1002/9780470294680.ch5>
- [18] Barker, Thomas B.: Quality by Experimental Design, *Marcel Dekker Inc.*, 1985
- [19] Cornell, John A.: Experiments with mixtures, 2nd Edition, *John Wiley and Sons, Inc.*, New York, 1990
- [20] Kemény, S. – Deák, A.: Mérések tervezése és eredményeik kiértékelése, *Műszaki Könyvkiadó*, Budapest, 1990
- [21] Bandemer, H.: Some Applications of Fuzzy Set Theory in Data Analysis II, D197, *VEB Deutsche Verlag für Grundstoffindustrie*, Leipzig, 1990
- [22] Rosato, D. V.: Specialized injection molding process. In *Injection Molding Handbook*, 2nd edition. Chapman & Hall GmbH, Weinheim, Germany, 1996
- [23] Mogyoródi, J. – Michaletzky, Gy.: Matematikai statisztika, *ELTE Természettudományi Kar*, Nemzeti Tankönyvkiadó, Budapest, 1995
- [24] Reimann, J.: Valószínűségszámítás és matematikai statisztika mérnököknek, *Tankönyvkiadó*, Budapest, 1992

Ref.:

Egész, Ádám – Buyakova, Svetlana P. – Kulkov, Sergey N.– Gömze, László A.: Optimization of ceramic manufacturing process using Plackett-Burman design of experiment
Építőanyag – Journal of Silicate Based and Composite Materials, Vol. 66, No. 2 (2014), 52–55. p.
<http://dx.doi.org/10.14382/epitoanyag-jsbcm.2014.11>

Kerámia gyártási folyamat optimalizálása a Packett-Burman kísérlettervezési módszer alkalmazásával

Jelen kutatásban a szerzők leírják a kerámia fröccsöntés folyamatát, annak legfontosabb jellemzőit. A kísérlettervezés módszerével bemutatják, hogy miként függ az egyes változtatható gépparamétereiktől a végtermék minősége, különös tekintettel a kerámiában előforduló repedések megjelenésére. Legfőbb megállapításként elmondható, hogy a fröccsöntéskor beállítható gépparamétereknek sokkal nagyobb hatásuk van a végtermék minőségére, mint a fröccsöntés hőmérsékletének. Ezen kívül elmondható, hogy a fröccsöntéskor a zöld termék tömegére az utónyomás nagysága van a legnagyobb hatással.

Kulcsszavak: alumínium-oxid por, paraffin wax, kerámia fröccsöntés, kísérlettervezés, feedstock

The manuscript must contain the followings: **title; author's name, workplace, e-mail address; abstract, keywords; main text; acknowledgement** (optional); **references; figures, photos with notes; tables with notes; short biography** (information on the scientific works of the authors).

The full manuscript should not be more than **6 pages including figures, photos and tables**. Settings of the word document are: 3 cm margin up and down, 2,5 cm margin left and right. Paper size: A4. Letter size 10 pt, type: Times New Roman. Lines: simple, justified.

TITLE, AUTHOR

The title of the article should be short and objective.

Under the title the name of the author(s), workplace, e-mail address.

If the text originally was a presentation or poster at a conference, it should be marked.

ABSTRACT, KEYWORDS

The abstract is a short summary of the manuscript, about a half page size. The author should give keywords to the text, which are the most important elements of the article.

MAIN TEXT

Contains: materials and experimental procedure (or something similar), results and discussion (or something similar), conclusions.

REFERENCES

References are marked with numbers, e.g. [6], and a bibliography is made by the reference's order. References should be provided together with the DOI if available.

Examples:

Journals:

[6] Mohamed, K. R. – El-Rashidy, Z. M. – Salama, A. A.: In vitro properties of nano-hydroxyapatite/chitosan biocomposites. *Ceramics International*. 37(8), December 2011, pp. 3265–3271, <http://dx.doi.org/10.1016/j.ceramint.2011.05.121>

Books:

[6] Mehta, P. K. – Monteiro, P. J. M.: Concrete. Microstructure, properties, and materials. *McGraw-Hill*, 2006, 659 p.

FIGURES, TABLES

All drawings, diagrams and photos are figures. The **text should contain references to all figures and tables**. This shows the place of the figure in the text. Please send all the figures in attached files, and not as a part of the text. **All figures and tables should have a title.**

Authors are asked to submit color figures by submission. Black and white figures are suggested to be avoided, however, acceptable.

The figures should be: tiff, jpg or eps files, 300 dpi at least, photos are 600 dpi at least.

BIOGRAPHY

Max. 500 character size professional biography of the author(s).

CHECKING

The editing board checks the articles and informs the authors about suggested modifications. Since the author is responsible for the content of the article, the author is not liable to accept them.

CONTACT

Please send the manuscript in electronic format to the following e-mail address: femgomze@uni-miskolc.hu and epitoanyag@szte.org.hu or by post: Scientific Society of the Silicate Industry, Budapest, Bécsi út 122–124., H-1034, HUNGARY

We kindly ask the authors to give their e-mail address and phone number on behalf of the quick conciliation.

Copyright

Authors must sign the Copyright Transfer Agreement before the paper is published. The Copyright Transfer Agreement enables SZTE to protect the copyrighted material for the authors, but does not relinquish the author's proprietary rights. Authors are responsible for obtaining permission to reproduce any figure for which copyright exists from the copyright holder.

Építőanyag – *Journal of Silicate Based and Composite Materials* allows authors to make copies of their published papers in institutional or open access repositories (where Creative Commons Licence Attribution-NonCommercial, CC BY-NC applies) either with:

- placing a link to the PDF file at **Építőanyag** – *Journal of Silicate Based and Composite Materials* homepage or
- placing the PDF file of the final print.



Építőanyag – *Journal of Silicate Based and Composite Materials*, Quarterly peer-reviewed periodical of the Hungarian Scientific Society of the Silicate Industry, SZTE.
<http://epitoanyag.org.hu>



Shizuo Horio

| 1932–2014

Életének nyolcvankettedik évében, türelemmel viselt betegség után, 2014. július 23.-án Tokyóban elhunyt Shizuo Horio úr, a Salgótarjáni Üvegyapot Részvénytársaság első japán igazgatóhelyettese.

A 2009-ben, sajnálatos módon megszüntetett gyár 1987-ben történt alapításában és létrehozásában Horio úr kezdettől fogva tevékenyen vett részt, mint a legnagyobb japán részvényes, a Nitto Boseki cég képviselője.

A gyár 1989 évi beüzemelését néhány hónappal megelőzően a japán részvényes csoport megbízta a termelés és kereskedelem helyszíni irányításával, és Magyarországra delegálta, mint a cég ügyvezető igazgatóhelyettesét.

Ezt a feladatát 1989 májusától 1994 év végéig látta el, folyamatosan Salgótarjában tartózkodva.

Tevékenységének kezdeti időszakában – a termelés felfuttatásának fázisában – a magyarországi politikai és gazdasági változások a vártnál is nehezebb feladatok elé állították a cég vezetését, amelyek megoldásában Horio úr szaktudása és tapasztalatai rendkívüli segítséget jelentettek.

A gyár működésének minden területén példamutató, kezdeményező és oktató vezetőként képviselte a családias légkörű gyári kollektíva érdekeit. Nagyon sok olyan japán vezetési, szervezési, minőségbiztosítási és elemzési módszert ismertetett és honosított meg, amelyek alkalmazása, évtizedeken keresztül, napi gyakorlattá vált.

Nagy hangsúlyt fektetett a kollektíva folyamatos értékelésére, a közös érdekrendszer tudatosítására, és a felelős gondolkodásmód kialakítására. Horio úr tevékenységét a gyár minden egyes munkatársa részéről nagy tisztelet és elismerés övezte.

Magánemberként rendkívüli barátot ismertünk meg benne. Magyarországi tartózkodása teljes öt évét felesége – Hiroko san – is együtt töltötte vele, aki segítője, és társa volt a munkálkodásában, elsősorban a rendszeressé és hagyományossá váló családos rendezvények szervezésében.

Horio úrral a kapcsolatunk hivatalos küldetésének lejártaival sem szakadt meg, több alkalommal ellátogatott feleségével együtt Magyarországra a gyár tulajdonosváltásait, majd bezárását követően is. Ilyenkor mindig kereste a lehetőséget a volt munkatársakkal való találkozásokra. A Salgótarjáni Üvegyapot Rt. kollektívája mindig meleg érzésekkel gondol vissza Rá, és tanításaira. A Tőle kapott ismereteket mind a mai napig sokan hasznosítják jelenlegi munkájuk során is.

Öszinte együttérzéssel osztozunk Családja gyászában.

Emlékét soha nem fogjuk elfelejteni.

Sayonara, Nyugodj Békében !

A gyári kollektíva nevében:

Frics Tamás nyugalmazott fejlesztési vezető

Pálmai Gyula üzemvezető

In his eighty-second year, after patiently enduring a long sickness, Horio Shizuo-san, the first Vice President of Salgótarjáni Üvegyapot Rt, passed away on July 23, 2014 in Tokyo.

As the representative of the largest Japanese shareholder, Nitto Boseki, Horio-san was instrumental in the 1987 foundation and setting-up of the factory, which sadly closed in 2009.

A few months before the factory started operation in 1989 the Japanese shareholder group trusted him with the task of managing production and sales in the field, and so he was delegated to Hungary as the company's managing Vice President.

He fulfilled this position from May 1989 until the end of 1994, remaining in Salgótarján throughout his term.

At the beginning of the factory's operation – during the ramping up of production – political and economic changes in Hungary had the company's leadership facing challenges greater than previously expected, and Horio-san's expertise and experience were invaluable in managing these difficulties.

In all aspects of the factory's operation he represented the interests of the close-knit group of employees as an exemplary, proactive and wise leader. He introduced numerous Japanese leadership, organizational, quality-assurance, and analytical methods, which became an essential part of everyday operation in subsequent decades.

He placed great emphasis on the constant evaluation of the community of employees, the adoption of common values, and the establishment of a responsible attitude. Horio-san's activity was greatly respected and admired by all employees of the factory.

Outside of work we got to know an exceptional friend in him. During the five years of his time in Hungary he was accompanied by his wife, Hiroko-san, who was his partner and helper, mainly in the organization of family events, which soon became a tradition.

Our relationship with Horio-san did not end with the conclusion of his official mission. He and his wife visited Hungary multiple times, even after changes in the company's ownership, and its ultimate closing. During these visits he always sought the opportunity to reconnect with old coworkers. He and his instructions live on as fond memories for the community of Salgótarjáni Üvegyapot Rt, and the knowledge he imparted is still put to good use by many in their work.

We offer our deepest sympathies to his family in this time of grief.

His memory will not be forgotten.

Sayonara, Horio-san, may you rest in peace.

In the name of the factory community:

Tamás Frics, retired Head of Development

Gyula Pálmai, Plant Manager

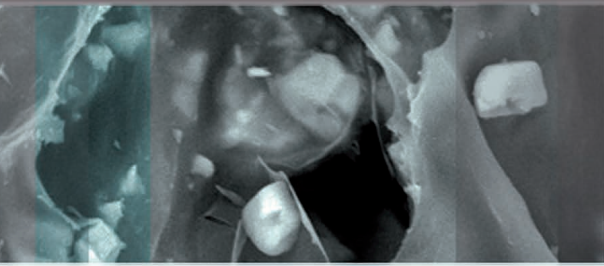

ic-rmm2

2nd INTERNATIONAL CONFERENCE ON RHEOLOGY AND MODELING OF MATERIALS

in Miskolc-Lillafüred, Hungary, 5-10 October, 2015.

Welcome to ic-rmm2

We are pleased to announce the organization of the 2nd INTERNATIONAL CONFERENCE ON RHEOLOGY AND MODELING OF MATERIALS to be held near city Miskolc in mountain Bükk in one of the most beautiful places of Hungary in Hunguest Hotel Palota Lillafüred, October 5-10, 2015.

The idea to organize in Hungary the 2nd International Conference on Rheology and Modeling of Materials we have received from prospective scientists, physicists, chemists, mathematicians and engineers from Asia, Europe, North and South America including China, India, Japan, Korea, Russia, Turkey, Estonia, France, Italy, United Kingdom, Chile, Mexico, USA. As organizers we hope that you will attend on ic-rmm2 and we are looking forward to welcome you on this international conference in Miskolc-Lillafüred, Hungary. Event ic-rmm2 is sponsored by several universities, scientific journals, societies and organizations around the World.



The objectives

The aims of the 2nd International Conference on Rheology and Modeling of Materials are the fostering of interdisciplinary collaboration and interaction among scientists, researchers, PhD students as well as product and technology developer engineers. The international conference ic-rmm2 provides a platform among leading international scientists, physicists, chemists, mathematicians, researchers, PhD students and engineers for discussing recent achievements in measurement, modeling and application of rheology in materials technology and materials science of liquids, melts, solids, powders, crystals and amorphous structures.

Among the major fields of interest are the influences of temperature, mechanical stresses, deformation speeds and times on rheological properties, material structures and phase transformation of foams, emulsions, suspensions, liquids, powders, crystals, foods, cosmetics, polymers, plastics, petrochemicals, melted metals, glass and competitive materials like nanomaterials, pharmaceuticals, medical- and biomaterials, ceramics, films and coatings, advanced metal alloys, composites, hetero-modulus, hetero-plastic and hetero-viscous complex material systems, hybrid materials, ... etc. Multidisciplinary applications of rheology as well as mechanical and rheological modeling in material science and technology encountered in sectors like food, bio- and medical materials, ceramics, glass, thin films, polymers, clays, construction materials, energy, aerospace, automotive and marine industry. Rheology in physics, chemistry, medicine, biosciences, cosmetics, environmental and earth sciences and in engineering and industries are of particular interests.

