

# CONCRETE STRUCTURES

ANNUAL TECHNICAL JOURNAL

György L. Balázs - Géza Tassi

**CULTURAL-HISTORICAL RELATIONS  
AND TECHNICAL CONNECTIONS  
BETWEEN THE NETHERLANDS AND  
HUNGARY**

János Schulek

**BUDAPEST METRO LINE 4  
UNDER CONSTRUCTION**

Antal Bedics - Gábor Dubróvzsky -  
Tamás Kovács

**DEVELOPMENT OF THE FI-150 PRE-  
CAST CONCRETE BRIDGE GIRDER  
FAMILY - DESIGN, PRODUCTION  
AND APPLICATION**

András Lontai - András Nagy -  
Tamás Mihalek

**VIADUCTS BUILT USING INCREMENT-  
AL LAUNCHING METHOD ON THE  
M7 MOTORWAY IN HUNGARY**

László Tóth

**UNDER DANUBE RIVERCROSSINGS  
OF PRESSURE PIPES WITH LARGE  
DIAMETER**

Attila Erdélyi - Erika Csányi -  
Katalin Kopecskó - Adorján Borosnyói -  
Olivér Fenyvesi

**DETERIORATION OF STEEL FIBRE  
REINFORCED CONCRETE BY  
FREEZE-THAW AND DE-ICING SALTS**

György L. Balázs - Tibor Kausay -  
Tamás K. Simon

**TECHNICAL GUIDELINE FOR  
RECYCLED AGGREGATE CONCRETE  
IN HUNGARY**

Sándor Fehérvári

**CHARACTERISTICS OF TUNNEL FIRES  
GYÖRGY L. BALÁZS - ZSOMBOR K. SZABÓ  
EXPERIMENTAL STRENGTH  
ANALYSIS OF CFRP STIPS**



2008

**Editor-in-chief:**  
Prof. György L. Balázs

**Editors:**  
Prof. Géza Tassi  
Dr. Herbert Träger

**Editorial board:**  
János Beluzsár  
Assoc. Prof. István Bódi  
László Csányi  
Dr. Béla Csíki  
Assoc. Prof. Attila Erdélyi  
Prof. György Farkas  
Gyula Kolozsi  
Dr. Károly Kovács  
Ervin Lakatos  
László Mátyássy  
László Polgár  
Antonia Teleki  
Dr. László Tóth  
József Vörös  
Péter Wellner

**Board of reviewers:**  
Prof. György Deák  
Prof. Endre Dulácska  
Dr. József Janzó  
Antónia Királyföldi  
Dr. Jenő Knebel  
Prof. Péter Lenkei  
Dr. Miklós Loykó  
Dr. Gábor Madaras  
Prof. Árpád Orosz  
Prof. Kálmán Szalai  
Prof. Géza Tassi  
Dr. Ernő Tóth  
Dr. Herbert Träger

Founded by: Hungarian Group of *fib*  
Publisher: Hungarian Group of *fib*  
(*fib* = International Federation for Structural Concrete)

**Editorial office:**  
Budapest University of Technology  
and Economics (BME)  
Department of Construction Materials  
and Engineering Geology  
Műegyetem rkp. 3., H-1111 Budapest  
Phone: +36-1-463 4068  
Fax: +36-1-463 3450  
WEB <http://www.fib.bme.hu>  
Editing of online version:  
László Bene

Price: 10 EUR  
Printed in 1000 copies

© Hungarian Group of *fib*  
ISSN 1419-6441  
online ISSN: 1586-0361

Cover:  
Tensile test on high strength carbon fibre  
FRP strip with a recently developed  
gripping device  
Photo: Zsombor K. Szabó

## CONTENT

- 2** György L. Balázs - Géza Tassi  
**CULTURAL-HISTORICAL RELATIONS AND TECHNICAL CONNECTIONS BETWEEN THE NETHERLANDS AND HUNGARY**
- 10** János Schulek  
**BUDAPEST METRO LINE 4 UNDER CONSTRUCTION**
- 15** Antal Bedics - Gábor Dubróvsky - Tamás Kovács  
**DEVELOPMENT OF THE FI-150 PRECAST CONCRETE BRIDGE GIRDER FAMILY - DESIGN, PRODUCTION AND APPLICATION**
- 23** András Lontai - András Nagy - Tamás Mihalek  
**VIADUCTS BUILT USING INCREMENTAL LAUNCHING METHOD ON THE M7 MOTORWAY IN HUNGARY**
- 27** László Tóth  
**UNDER DANUBE RIVERCROSSINGS OF PRESSURE PIPES WITH LARGE DIAMETER**
- 33** Attila Erdélyi - Erika Csányi - Katalin Kopecskó - Adorján Borosnyói - Olivér Fenyvesi  
**DETERIORATION OF STEEL FIBRE REINFORCED CONCRETE BY FREEZE-THAW AND DE-ICING SALTS**
- 45** György L. Balázs - Tibor Kausay - Tamás K. Simon  
**TECHNICAL GUIDELINE FOR RECYCLED AGGREGATE CONCRETE IN HUNGARY**
- 56** Sándor Fehérvári  
**CHARACTERISTICS OF TUNNEL FIRES**
- 61** György L. Balázs - Zsombor K. Szabó  
**EXPERIMENTAL STRENGTH ANALYSIS OF CFRP STRIPS**

### Sponsors:

Railway Bridges Foundation, ÉMI Kht., HÍDÉPÍTŐ Co.,  
MÁV Co., MSC Hungarian SCETAUROUTE Consulting Co.,  
Pfleiderer Lábatlani Vasbetonipari Co., Pont-*TERV* Co., UVATERV Co.,  
MÉLYÉPTERV KOMPLEX Engineering Co., SW Umwelttechnik Hungary Ltd.,  
Betonmix Consulting Ltd., BVM Épelem Ltd., CAEC Ltd., Pannon Freyssinet Ltd.,  
STABIL PLAN Ltd., UNION PLAN Ltd., DCB Consulting Ltd.,  
BME Dept. of Structural Engineering,  
BME Dept. of Construction Materials and Engineering Geology

# CULTURAL-HISTORICAL RELATIONS AND TECHNICAL CONNECTIONS BETWEEN THE NETHERLANDS AND HUNGARY FOR THE OPENING OF THE *fib* SYMPOSIUM, AMSTERDAM 2008



György L. Balázs – Géza Tassi

*Our periodical has recently featured a leading article dealing with our relationship to the host country of the forthcoming fib event. The fib Symposium, Amsterdam 2008, will be a good occasion for a review of the past in the hope that this will give encouragement for future development.*

## 1. INTRODUCTION

Despite of the relatively large geographical distance between the Netherlands and Hungary, there has been a spiritual link lasting some centuries.

Recent cultural connections in music and fine arts have strongly developed. When Hungary joined the European Community political, trade and financial relationships with the Be-Ne-Lux countries greatly improved. Belonging to the same system of the Schengen borders, commercial, industrial, transportation and tourism cooperation will also develop.

Common activity in the building industry had not previously been strong. However, considering the noteworthy increasing of Dutch construction work in Hungary, it is worthwhile to note examples in this field. The international scientific societies, among them the parent organisations of *fib* have notable merits in the advantageous cooperation of Dutch and Hungarian engineers.

Noblesse oblige! – as the French proverb says. The noble tradition of the congresses and symposia of *fib* is also an obligation for the Hungarian members and thus their only endeavour is to prove worthy of this tradition. The following short review aims to be a humble contribution to it and, above all, to the success of the symposium in Amsterdam.

## 2. DUTCH-HUNGARIAN RELATIONSHIPS IN CULTURE AND HISTORY

Anybody wishing to make a short report about the subject outlined in the title finds such a wealth of information as to cause the chronicler to face almost insurmountable difficulties. A first observation, however, results in the conclusion that there is no balance in the interrelations between Holland and Hungary as Hungary has received far more from the Netherlands and Amsterdam than it could even return.

There was no significant relationship between the Netherlands and Hungary before two very significant events of European history, namely the revolt of the Netherlands and the Reformation.

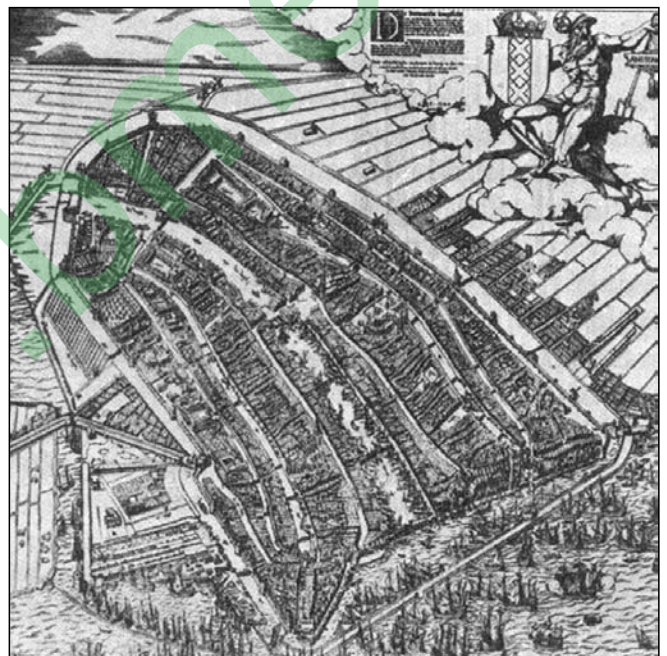

**Fig. 1:** Bird's eye view of Amsterdam, engraving of Cornelis Anthoniszoon from the 17<sup>th</sup> century

In the preceding centuries there might have been only a dozen learned Hungarian clergymen who knew of the river Amstel flowing into the North Sea and of the little settlement in its neighbourhood, of which industrious inhabitants had fought with dams both against the sea and the river. In time both the name of the river and the dam next to it were amalgamated into Amstelodam (Kiss, 1988) preceding the present name of the economic centre of modern Holland, Amsterdam (Fig. 1).

The civil engineers of today, however, will be particularly grateful that this long historical process full of vicissitudes, had at least been commemorated in the name of the excellent beer of the region „Amstel”. Noteworthy enough is that the form „Amstelodam” for Amsterdam remained long in the memory and practice of the learned people, as confirmed by the old prints of this review.

There is no place in such a short report to detail the events of the revolt in the Netherlands which resulted in independence from Spanish rule of seven northern provinces – among them

Holland and Zeeland. Nevertheless, mention must be made to the political wisdom of William of Orange, of his heroic Sea-Beggars and last but not least, of van Oldenbarneveldt and Maurice of Nassau who were responsible for forging the welfare of the new country. The military efforts and successes of Maurice finally brought about the Truce 1609, laying the foundation of a prosperous Holland and its present royal dynasty.

Along with the political independence and the growing influence of Calvinism, Holland became a stronghold not only of the reformation but of the knowledge as well. The Dutch had long been experienced sailors and shipbuilders and their maritime trade and colonial enterprises rendered the country a place of almost miraculous economic development (Green, 1952). As a consequence of prosperous trade and industry, at the beginning of the 17th century, Amsterdam was home to some 105,000 inhabitants, while a century later in Buda and Pest there were only about 10,000 inhabitants (Zumthor, 1985, Pásztor, ~1900).

Due to the liberal mentality and spirit of Amsterdam a large number of people from all over the world came and settled in that city. They came partly in order to learn or to make business, and partly in order to find refuge from the harassments of the counter reformation at home.

Among them there were also many Hungarian intellectuals or other men of learning with some connection to Hungary. János Bánffy-Hunyady, a Hungarian born, spent almost all of his adult life in England and there earned a name as an alchemist (Szathmáry, 1928). Towards the end of his life he moved to Amsterdam where he died in 1646.

J. Amos Comenius (1592-1670), famous for his work „Orbis pictus”, was one of the outstanding personalities of European education at that time. After a four years employment at the Hungarian protestant college of Sárospatak, he also moved to Amsterdam. He found there a vibrant scientific environment and also peace in his remaining years. Having been the bishop of the protestant community of the Czech Brothers he became persona non grata in his Czech homeland. Comenius was alone with this problem with this problem of faith (Benedek, 1927). In the spring of the year 1674, scores of protestant preachers in Hungary were accused with a charge of high treason. The charge, process was rather complicated, undeniably directed against Protestantism. In September 1674 the defendants were finally condemned to the galleys, which at that time was not an exceptional punishment.

Some nevertheless died while en route to sea, and the others suffered much in their bondage until the famous Dutch Admiral of the time, Michiel Adriaanszoon de Ruyter, on the 11th February 1679, liberated them near Naples. The preachers become martyrs of the protestant faith and both their suffering and their liberation by Admiral de Ruyter was commemorated sometime later with a column at the garden of the protestant college in Debrecen in Hungary. As a sign of apology and reconciliation Pope John Paul II laid a wreath on the base of the column during his first visit to Hungary (S. Varga, 2002) (Fig. 2).

A more uplifting aspect of our connections is learning. The outstanding professor of theology at the Franeker University, Johannes Cloppenburg (1592-1652) was born in Amsterdam. He not only supported many of protestant students from Hungary, but he had a special interest for books published in Hungary, as well. His library, which was bequeathed to the university, contains several prized rarities of contemporary Hungarian printing.

Apart from books, professor Cloppenburg maintained



Fig. 2: Picture of Admiral Michiel Adriaanszoon de Ruyter, engraving of Abraham Blooteling from the 17<sup>th</sup> century

friendly dialogue with his Hungarian students. As a sign of affection, these students, returning back from their vacation, frequently brought gifts of famous Hungarian wines to the professor (Eredics, 2001):

The opportunities provided by the socially and intellectually developed Netherlands to the talented young Hungarian student, János Apáczai Csere (1625-1660) brought him to conclude that traditional Latin education at home did not furnish students with necessary knowledge. He believed that a broad encyclopaedic knowledge was more functional and in order to facilitate this, shortly after completing his studies in the Netherlands, he published in Utrecht Volume I of his Hungarian Encyclopaedia. Filled with great plans and accompanied by a young Dutch wife, Aletta van der Maet, he returned home to Hungary. His ideas were met with lack of interest and he died young and disappointed (Benedek, 1927), (Fig. 3). Apáczai Csere's work, which was largely based on his studies in Holland, proved in the long term to be durable.

The famous professor of the Hungarian Protestant College in Debrecen, György Maróthy (1715-1744), also studied in Amsterdam. After returning home, he wrote a basic textbook about arithmetic and in it he also set out a theorem of music (Benedek, 1927).

Where education was at a high standard, as was the case in the Netherlands during the Golden Age, printing of books must also have been at a high level. During this period in no



Fig. 3: Frontispiece of the Hungarian Encyclopaedia by János Apáczai Csere printed in Utrecht

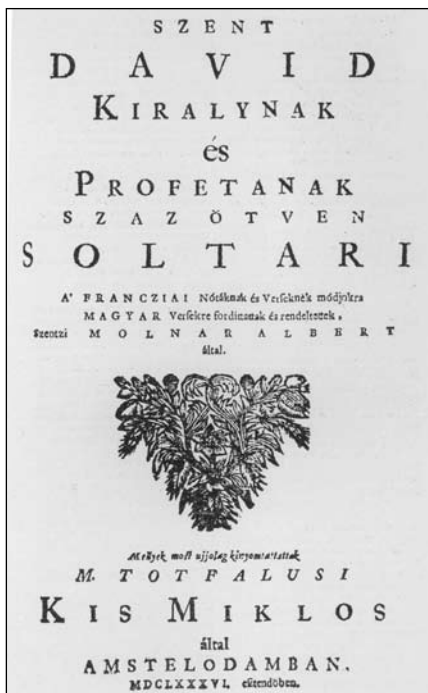

Fig. 4: Frontispiece of the Psalms printed by Miklós Tótfalusi Kis in Amsterdam

man, Miklós Tótfalusi Kis (1650-1702) to learn the rather complex profession of printing.

In three years the young man became so skilled in letter cutting that Blaeu could supply his letters to leading English printers. He also cut letters by royal order for the king of Georgia. Miklós Tótfalusi Kis learned the finest secrets and tricks of typography. During his stay in Amsterdam he was able to realize an old and dear dream, the reprinting of the Hungarian Bible. Among his other and later excellent prints, the small format "Golden Bible", bearing the emblem of the Elsevier, was truly a masterpiece of the Hungarian typography. Before returning home from Amsterdam he also printed the Psalms in Hungarian, according to the translation of the protestant humanist, Albert Szenci Molnár (Fig. 4).

Not only masters of book printing, the Dutch were also seafaring people who needed maps. Where book printing was of a high standard, the printing of maps went with it hand in hand. There is insufficient space to detail here the outstanding



Fig. 5: Title print of the map of Hungary engraved by Frederik de Wit - Amsterdam

other country in Europe was there so high a number of booksellers as in the Netherlands. Booksellers were normally printers as well as publishers. Beyond doubt the leading names in this field were the Elsevier (Elzevir, Elzevier) from Leiden (from 1581 to 1712), and the Plantins of Antwerpen. There was also the famous Blaeu printing house in Amsterdam and to this printing

house came the young Hungarian

cartographers of the age who published several excellent and artistic maps which included Hungary, but among them Abraham Ortelius (1528-1598) from Antwerp (Belgium) is worth mentioning. Beautiful maps had also been engraved by both Johannes de Ram (1648-1693) and Frederik de Wit (1616-1689) who worked in Amsterdam (Szántai, 1996) (Fig. 5).

The civilisation of the Netherlands and its influence upon Hungary is much more varied than has been sketched in the above lines. Among others not previously mentioned were paintings and other objects of fine art. The skill of Dutch painters quickly attracted attention of Hungarian museums where to this day a number of excellent works of outstanding Dutch painters can be seen on permanent and temporary exhibitions. Similarly, the paintings the Dutch cult of flowers, especially

that of the tulip, ("tulipomania" as the passion for the tulips was named at this time) influenced and also slightly "infected" several contemporary Hungarian aristocrats and their painters. Though the tulip itself was introduced into Hungary by the Turks some time earlier as with



Fig. 6: A Turkish tulip of Heinrich Herwart -Augsburg, 1559. The first picture of the tulip in Europe

other countries of Western Europe (Rapaics, 1932) (see Fig. 6), the multifarious types came here from the Netherlands in order to decorate gardens and to enrich the fantasy of painters. Thus the Hungarian artist, Jakab Bogdány, depicted gaudy tulips in his still-life compositions, as did his Dutch contemporaries, Ambrosius Bosschaert senior (1573-1621) and Jan van Huysum (1682-1749) (Zumthor, 1985).

This survey, of course, cannot be complete but it shows the worthy connection between the Netherlands and Hungary centuries ago.

### 3. SOCIAL AND CHARITABLE CONNECTIONS

Unfortunately, wars, crises and other difficulties hindered international life and limited good commercial and industrial cooperation for long periods.

#### 3.1 Dutch help for Hungarian people at different periods

After WWI, the Dutch people generously welcomed hundreds of Hungarian children to remain in the Netherlands for an extended period of time. Dutch families brought these children into their homes and took good care of them. These children later acknowledged sincerely their gratitude and remembered their hosts as "my Dutch father and my Dutch mother".

After the 1956 Hungarian revolution Dutch organizations helped many Hungarian citizens who have found a new home in the Netherlands.

## 3.2 Cultural, educational and professional links

A Hungarian Federation in the Netherlands was formed principally for cultural programmes. The Hungarian Federation has connections to six member groups, 11 societies, a Hungarian home, kindergartens and schools, 13 folklore ensembles, connection to two university chairs for Hungarian language, to churches, theatre and cinema. They maintain links with foundations, manage relationships between twin towns, clubs, health organisations etc.

As an example: In Utrecht in 1951 a cultural association caring for the cultural values of Hungarians living in emigration was founded and named after Kelemen Mikes (a companion in exile of Prince Ferenc Rákóczi II in the early 18th century).

Traditionally good links have also been forged with educational organisations in several universities of both countries, thus the institutes of the Netherlands are flourishing in Hungarian universities. A happy example of such a connection comes via IAESTE (international students' exchange), where a student from the Netherlands Frederik Sjerps spent time during 1995 at the Budapest University of Technology and worked in the field of concrete structures. He married a Hungarian girl Nóra Sándor with the most joyful outcome of this connection being that they had a Dutch-Hungarian baby.

Another good indication of the sound relationship existing between Holland and Hungary was the first festival of Hungarian wines and gastronomy to have been organized in Amsterdam during October 13-14, 2007.

Similar common events are increasing nowadays.

## 4. DUTCH-HUNGARIAN LINKS IN WORLD OF TECHNICAL SCIENCE AND PRACTICE

### 4.1 General relations

As the time passed the connections between our two countries took on different forms. After the WW I. many Hungarian students spent their holidays in Holland with the aid of Dutch organizations of charity.

It is not possible to give an overall survey of the activity of Hungarian civil engineers in the Netherlands, but we can mention a few good examples. On the other direction, from among works example will be discussed in which there was a significant contribution by our Dutch colleagues.

The next memorable year of the good relations between the two countries was 1956 when after the revolution a lot of Hungarian people could find refuge and also a new home in Holland among them specialists in building industry.

Another example is of young Hungarian architects (G. Bachmann, I. Bak, T. Trombitás) who in June 1-30, 1987 were presented in Amsterdam with the title "De Constructie".

### 4.2 Hungarian civil engineering activity in the Netherlands

Pál Sávolý (1893-1968, Fig. 7) was an outstanding designer in the field of engineering structures (Kozma, 2003). Among other works, he is famous as chief designer of the Elizabeth Bridge across the Danube in Budapest. Until 2007 this steel cable suspension bridge had the largest span in Hungary. P. Sávolý



Fig. 7: P. Sávolý

had been working for some time in the design bureau of Paul Würth in the Netherlands where he participated in designs of major projects. He then undertook individually important engineering works in Belgium and Luxemburg, as well as in other European and far East countries. He had significant projects in the Netherlands such as the steel structure of the Amsterdam Central Railway Station (Fig.

8), a 260 m long bridge across the Haarlem Canal, railway viaduct in Rotterdam, industrial building for Pluto Ltd., corrugated iron sheet factory and dwelling houses in Nymegen, bascule moving bridge at the Kings Harbour in Rotterdam,



Fig. 8: Steel structure of the roof of the Amsterdam central railway station.

also important solutions for the Rotterdam seashore airport and others. The experience which P. Sávolý received in the Netherlands defined his activity in Hungary and other countries.



Fig. 9: L. Vákár

A noteworthy example of very productive work of Hungarian engineers emerging from the emigration post the 1956 revolution is the performance of Dipl.-Ing. László Vákár (1926), (Fig. 9) and his son Ir. László I. Vákár (1953).

Before speaking about the work of L. Vákár it is worth remembering the Hungarian people who were already in Holland at the time of his arrival. There was a house in Delft called "Our home" (in Hungarian) where a few Hungarian families were accommodated. There were two Hungarian professors of other faculties who assisted with the integration of new immigrants. Additionally there were the Sipkovits



**Fig. 10:** Vörösmarty Square building in Budapest downtown constructed by Dutch contractors

brothers, who belonged to the Civil Engineering and to the Architecture faculties of the University. L. Vákár graduated from the Technical University of Budapest and started his carrier in Hungary designing hydraulic establishments. He arrived to the Netherlands in 1956 as a refugee (Balázs, Tóth, Borosnyói, 2007). He was employed by the NEDAM company where he carried out contracting designs of the tunnel under the IJ river in Amsterdam. Later, at a consulting bureau, he designed, among others, the structures of the archive in Haarlem, a social building in Amsterdam, and the buildings for the Mathematics-Physics department of the Amsterdam free university. After 1960 he worked in the faculties of both Civil Engineering and Architecture, teaching design of industrial and other buildings. In his own design firm, he designed many significant buildings such as those for the medical faculty of the Amsterdam free university. During 1975-80 he was a full time staff member of the Delft university, teaching structural design. At the same time in his own office he designed noteworthy structures e. g.: the Police Headquarters in Haarlem, the halls of Factor Fasson NL, the Soefi church at Katwijk, the sport hall of the Amsterdam University of Science, the sport hall in Bellevoetshuis, the Town Hall of Haarlemmermeer, as well as a number of residential dwellings, schools, office buildings, churches and industrial structures. L. Vákár also worked at the Dutch national society for timber structures and he is an acknowledged specialist in this field.

The son of L. Vákár, L. I. Vákár was born in Hungary, and in 1956 when the family emigrated to the Netherlands, he was three years old. He graduated as Civil Engineer in Delft in 1978. He published many papers on his work. Among other projects the roof of the bus station behind the Amsterdam central railway station was constructed after his design. He patented cold bending of glass (Vákár, 2004) and the elastic support of the cylindrical glass elements. (His patent exists in Hungary also.) The special feature of these roofs is the very high fire resistance. The concrete stairs on the platform were also designed by him. Another of his designs is a steel structure for a roof spanning 60 m with glass elements suspended on the steel structure.

High voltage electric lines were established with glass

insulation. This technology protected against the harmful effects of radiation and enabled the construction of buildings and other establishments along the 350 m protecting zone.

Environmental protection against noise, vibration and air pollution created by several hundred kilometres of motorways was facilitated by a covering of steel and glass. The problem of ventilation was solved and the heat produced by the extraction of exhausted gases was harnessed as a source of heat supply for the neighbouring buildings. Storage of this energy was also solved using the behaviour of ground water. Thus the strip parallel to the motorway could be used in a functional way, yielding economic and environmental gains and efficiencies.

### 4.3. Dutch builders in Hungary

The role of Dutch investments in Hungary and that of the contribution of engineers from the Netherlands is significant. In this chapter we can only highlight examples of recently completed works in Hungary by specialists from the Netherlands.

There is today an intensive activity by Dutch organizations working in Hungary. For example the architect who designed the new Embassy of the Netherlands in Budapest, Fred Dubbeling, is also honorary consul representing Hungary. In the past he has participated in the management of the Hungarian design bureau for industrial building, the Iparterv.

After the change of political regimes in central Europe, the Dutch real estate development and investment company, ING Real Estate, was one of the first major international enterprises to establish its activities in Hungary. Since 1992 ING Real Estate Development invested over €300 million in seven projects covering office, retail and residential segments of the market. Each project had a landmark architectural character, earning numerous industry and architectural awards in Hungary and abroad. Since 2000. ING became a “green developer”, paying special attention to the economic, environmental and social sustainability of its buildings. The Vörösmarty building in the main public square of downtown Budapest illustrates ING’s commitment to sustainable urban

locations and high quality architecture. (Fig. 10). The above information is provided by P. Baross, a well known specialist of Hungarian origin who managed the greater part of Dutch investments in Hungary.

## 5. CONNECTION IN THE FRAMEWORK OF *fib* = CEB + FIP

### 5.1 Events from foundation until 1990

At the time of the foundation of the parent organizations of *fib* there was no direct Hungarian link to the international associations.

The FIP Congress in Amsterdam (1955) was the first event which drew the attention of Hungarian specialists to the existence of the federation. With the first steps towards to planning of FIP, we had discussions with the famous engineer from the Netherlands Dr. G. F. Janssonius (1911-1990), (Fig. 11) with whom we became personally acquainted at the IABSE Congress 1960 in Stockholm. He encouraged Hungarian scientific societies to join FIP, and was one of the first to motivate the Hungarian delegation to attend the FIP Congress Rome-Naples 1962.



Fig. 11: G. F. Janssonius

Dr. Janssonius was elected as President of FIP at the Congress in Prague 1970. Dr L. Garay and Prof. Gy. Balázs Sr. were Hungarian delegates at the General Assembly where the election took place. Good relations were cemented during one of the early visits of the new president through his participation at the meeting of the Hungarian Group of FIP in Budapest November 1970. The program was a report on the Prague Congress by seven participants of the populous Hungarian delegation, and Dr. Janssonius also addressed the audience. This was a good opportunity to introduce the Hungarian capital to the President, and, included the performance in the Hungarian State Opera. The “three Bartók’s” were on. We got known that Dr. Janssonius and his wife were enthusiasts of music of Béla Bartók.

Two years later during 1972, national groups of FIP were invited to the FIP days in the Netherlands. The host organisation under the leadership of Dr. Janssonius, gave an overview of recent achievements in Dutch concrete construction. Participants visited the works of the Amsterdam underground



Fig. 13: J. H. van Loenen

and the bridge across the Waal River at Tiel among other site visits. The riverbed bays were spanned by a continuous structure with concrete towers, stiffening girder and stays (Tassi, 1973) while the flood area bays were constructed by free cantilevering using site prefabricated box segments (Fig. 12). The designer was J. H. van Loenen (FIP Medallist 1986, Fig. 13) with whom



Fig. 12: Construction of the bridge across the Waal River, the flood area structure. (In the figure D. Dalmy, member of the Hungarian delegation, today manager of Pannon Freyssinet Ltd. and member of the Palotás László award board of trustees of Hungarian Group of *fib*)

the Hungarian FIP Group nurtured contact over many FIP events.

In 1974 Dr. Janssonius helped the Hungarian delegation to participate at the New York FIP Congress. Let us mention here that Dr. Janssonius was made Honorary President in 1975 and awarded the FIP Medal 1980.

There was good cooperation between Dutch and Hungarian specialists in the framework of CEB also. At the Plenary Session in Delft-Scheveningen 1969 Hungary was in attendance. In 1980 when the Plenary Session of CEB took place in Budapest, Hungarian organizers were in good communication with delegates from the Netherlands.



Fig. 14: J. den Uijl

The CEB Task Group VI/1 started its activity in 1979. The authors of this paper, as well as other Hungarian members, worked in this task group. They had an enduring cooperation with J. den Uijl (Fig. 14) who was present at the task group meeting held in Budapest and Pécs.

There was a FIP Council Meeting in Budapest in October 1981. G. F. Janssonius was present as past president and representative of the Dutch FIP Group, H. J. C. Oud also contributed to the discussion.

CEB had its 24<sup>th</sup> Plenary Session in Rotterdam, 1985. Hungarian delegates L. Erdélyi, I. Bódi, P. Lenkei, G. Tassi (now both honorary lifetime presidents), and G. Madaras, current vice president of the Hungarian Group as well as G. L. Balázs current president of the Hungarian Group, P. Lenkei participated in the General Assembly, and G. Tassi at task group meetings. The session was of great interest as was the visit to the giant seashore hydraulic works and bridges. At the time of the session Hungarian delegates were welcomed by the “Fakulteit der Civile Technick, Technische Universiteit Delft” and had an opportunity to study recent research work in concrete technology.

There was an FIP Council meeting in Amsterdam 1987 when the first idea was seeded of a FIP symposium to be held in Hungary.



## 5.2 The years after 1990

The FIP Congress 1990 in Hamburg and the Beijing Symposium 1991 commission and task group whose works strengthened international connections. In great part this became better because of the easier communication as one result of the political changes in East-Central Europe.

The FIP Symposium in Budapest held in 1992 provided a good opportunity to improve on close connections with our Dutch colleagues as with others.

H. J. C. Oud was a member of this Scientific Committee. The members of the Dutch delegation played an important role at these sessions. Participants had the opportunity to attend the lectures of K. van Breugel, A. S. G. Bruggeling, M. H. M. G. Ronde, J. N. J. A. Vambersky and R. Veldhuijzen van Zanten.

At the FIP Congress held in Washington, 1994 it was decided that the XIII<sup>th</sup> Congress should take place in Amsterdam. This decision was celebrated with a reception at the Embassy of the Netherlands in U. S. A. The guests amazed at two persons who spoke a few words to the Ambassador in an special language. The solution to this mystery was that the Ambassador, Adriaan



**Fig. 15:** M. Márkus (President of Hungarian Scientific Society for Building), A. Jacobovits de Szeged (Ambassador of the Netherlands in Washington) and H. J. C. Oud (Deputy-President of FIP)

Jacobovits de Szeged, had one branch of his family from Hungary (Fig. 15). He is known as an excellent expert of East Europe.

FIP held its Council Meeting in Utrecht, 1996 and one of the important point of the agenda was the preparation of the FIP Congress Amsterdam in 1998. Participants of this meeting made an excursion to the site of the congress. Both authors of this paper were present, G. L. Balázs was welcomed on the occasion of his first visit after being elected as secretary of the Hungarian Group of FIP (Fig. 16).



**Fig. 16:** Participants of the FIP Council Meeting Utrecht 1996.



**Fig. 17:** J. Walraven

The XIII<sup>th</sup> FIP Congress in Amsterdam in 1998 provided an opportunity to expand cooperation with colleagues from the host country. Joost Walraven (Fig. 17) from his previous activity at CEB events was well known among Hungarian engineers dealing with concrete, and this connection was reinforced after he was elected as President of *fib*. He visited Hungary several times.

The last FIP congress, prior to the merger with CEB, was an excellently organized meeting. The Hungarian delegates had extensive contact with the members of the scientific and organising committees and with members in the first row: J. Walraven, H. J. C. Oud and D. Stoelhorst. The Hungarian Group was represented by numerous delegates. There were four Hungarian presentations. Furthermore, G. L. Balázs, who was that time already the president of the Hungarian Group, was chairman of the session of the Commission for Serviceability Limit States.

Hungarian delegates summarised their experience at a meeting in Richard Restaurant in Amsterdam (Fig. 18). In



**Fig. 18:** Hungarian speaking participants of the FIP Congress Amsterdam 1998.

December 1998 there was a conference in Budapest where the delegates reported to the audience on the congress in Amsterdam.

## 6. CONCLUSIONS

Historical links between the Netherlands and Hungary date back many centuries. In the past the activities of Hungarian scientists and specialist were significant. Some found opportunities to learn and work in Western Europe. After World War I and the Hungarian Revolution of 1956, Dutch institutions of charity played an important role in this link. At both of these historical events there were Hungarian specialists of excellence who contributed to the Dutch construction industry. Subsequent to the political changes in Hungary after 1990, contracting firms from the Netherlands produced significant building structures in Hungary. A special field of cooperation has been the common activity under the frame of *fib*=CEB+FIP. International professional associations find many good opportunities to acquire and share technical expertise by means which can be realised by means of congresses and symposia (Tassi, Balázs, Borosnyói, 2005).

We hope that the *fib* Symposium 2008 Amsterdam continues to provide a good opportunity to improve this active cooperation.

## 7. ACKNOWLEDGEMENT

The lion part of contribution to this paper was done by Dr.-techn. L. Bajzik, who collected, forged and strengthened significant links between Holland and Hungary in centuries old bygone historical days. The authors express their gratitude. We are grateful also for the worthy contributions of Mr. L. Vákár, Mrs. I. Márkus, Mr. P. Baross and Mr. G. Németh.

## 8. REFERENCES

- Balázs, Gy., Tóth, E., Borosnyói, A. (2007): „Civil engineers graduated from the Technical University 1943-1951” (In Hungarian), Műegyetemi Kiadó, Budapest.
- Benedek, M. (editor) (1927): „*Encyclopaedia of literature*” (In Hungarian), Győző Andor publisher, Budapest.
- Eredics, P.(2001): „Hungarian books of Professor Johannes Cloppenburg” (In Hungarian), Magyar Könyvszemle, 117/1.
- Green, V. H. H. (1952): „*Renaissance and Reformation*”, Edward Arnold Publishers, London.
- Haiman, Gy.(1972): „*Tótfalusi Kis Miklós – the letter artist and printer*”, (In Hungarian), Magyar Helikon, Budapest.
- Kiss, L., (1988): „*Etimologic dictionary of geographical names*” (In Hungarian), Akadémiai Kiadó, Budapest.
- Kozma, K. (2003): „*Pál Sávoly, Creative Hungarians – Hungarian engineers*” (In Hungarian), Budapesti Történeti Múzeum, Budapest.
- Pásztor, M. (without date, about 1900): „*Buda and Pest after the Turkish rule*”, (In Hungarian), Budapest Székesfőváros Házinyomdája, Budapest
- Rapaics, R.(1932): „*The flowers of Hungarian people*” (In Hungarian), Királyi Magyar Természettudományi Társulat, Budapest.

- S. Varga, K. (translator).(2002): „*They are brought to the jury. Protocol of the trial of galley-slaves in 1674.*” (In Hungarian), Kaligram, Bratislava-Pozsony.
- Szántai, L.(1996): „*Atlas Hungaricus, printed maps of Hungary 1528-1850*” (In Hungarian), Akadémiai Kiadó, Budapest.
- Szathmáry, L.(1928): „*Hungarian alchemists*” (In Hungarian), Királyi Magyar Természettudományi Társulat, Budapest.
- Tassi, G. (1973): „Suspension and free cantilevered prestressed concrete bridge structures” (In Hungarian), *Mélyépitésstudományi Szemle*, Budapest. pp. 522-526.
- Tassi, G. (2003): „History of the Hungarian FIP Group from the beginning to 1998” (In Hungarian), *Vasbetonépítés*, (special issue), Budapest.
- Tassi, G., Balázs, L. G., Borosnyói, A. (2005): „Benefit of technical-scientific symposia”. *Concrete Structures*, p. 2.
- Vákár, L. I., Gaal, M. (2004): „Cold bendable laminated glass. New possibilities in design”, *Structural Engineering International*, 14/2, pp. 95-97.
- Zumthor, P.(1985): „*Weekdays of Holland in age of Rembrandt*” (In Hungarian), Gondolat, Budapest.

**Prof. György L. Balázs** (1958) PhD, Dr. habil, professor in structural engineering, head of Department of Construction Materials and Engineering Geology at the Budapest University of Technology and Economics. His main fields of activities are: experimental and analytical investigations as well as modelling reinforced and prestressed concrete, fibre reinforced concrete (FRC), fibre reinforced polymers (FRP), high performance concrete (HPC), bond and cracking in concrete durability and fire resistance. He is convenor of *fib* Task Groups on “Serviceability Models” and “*fib* seminar”. In addition to he is a member of several *fib*, ACI and RILEM Task Groups or Commissions. He is president of the Hungarian Group of *fib*. Member of *fib* Presidium.

**Prof. Géza Tassi** (1925), PhD, D.Sc., active (semi retired) in the Department of Structural Engineering of the Civil Engineering Faculty, Budapest University of Technology and Economics. His main fields of interest: reinforced and prestressed concrete, concrete bridges. He is lifetime honorary president of Hungarian Group of *fib*, lifetime honorary member of the Hungarian Scientific Society for Building and the Hungarian Chamber of Engineers, FIP-medallist, awarded at the 1st Congress of *fib*, holder of Golden Ring and Golden Diploma of the Budapest University of Technology, Palotás László Prize winner (Hungarian Group of *fib*).

# BUDAPEST METRO LINE 4 UNDER CONSTRUCTION



János Schulek

*The fourth metro line in Budapest had gone through a long preparatory period and many political skirmish before it entered the implementation phase, but there are still debates and misapprehensions surrounding it. In spite of all these, it is being built continuously, and it is trudging along the difficult path of implementation, overcoming heaps of technical problems, as a result of cooperation between numerous civil engineering design areas and even more persons. This article concerns the preparation period of the metro line, from the very first alignment plans through several phases until implementation. It is the first part of a report. A later publication will outline the details of the structural and technological solutions of the metro structures, made almost entirely out of reinforced concrete.*

**Keywords:** tunnel, tunnel shield, tubbing ring, diaphragm wall, reinforced concrete slabs

## 1. PREPARATION BETWEEN 1970 AND 1996

Preparation aiming to locate the actual line and to analyze its feasibility dates from 1970, and it has continuously kept designers, building contractors, investors and decision makers busy in Budapest and throughout the country. The implementation of the third metro line had been almost finished and everyone considered it logical to continue building the metro, as there were still some important areas in the two-million metropolis without rapid rail-mounted transport. In order to make the project fit the budget, new building and implementation ideas came up again and again. The idea of building the metro from Soviet (later Russian) debt and the turnkey metro building offer by the French company MATRA were significant milestones. The idea of a world exhibition, dating from the 1980s, which connected the metro line 4 to the Expo in many different ways was also important. The change of political system in Hungary that brought about the establishment of the self-government system did not change the fact that the actual construction was far from underway.

The first Municipal Government of Budapest, established in 1990, reinitiated talks on metro building, and after the supporting decision of the Government a new turnkey building tender combined with finance was published. After two years of procrastination the tender was once again declared unsuccessful because the Municipal Government was given an offer for a more favourable credit construction from the European Investment Bank than those of the commercial banks, which, however, required a state guarantee (Schulek, 2005).

## 2. FEASIBILITY STUDY

A feasibility study of the metro line had to be made as the precondition of the bank credit. Its main task was to report on the return the bank could expect on its investment, and to finalize the track and the metro system. A design team of the English Symonds Travers-Morgan, the French Systra and nine Hungarian design companies brought together by Főmterv won the international tender financed by PHARE funds. The Study comprehensively analysed possible variations, namely surface alternatives, light rail transit (LRT) systems and the metro options. The alternative that has served as basis for preparation

up to the present was chosen in a multi-step process out of nine metro line options, six LRT alternatives, one combined surface option and one that extended the existing metro line 2. The suggested and accepted option was a metro line that runs from Újpalota in Pest to Budafok in Buda, branching off to Budaörs (Flower market). It was decided that the section between Etele square and Keleti pályaudvar (Eastern railway station) can be built in the first phase, as passenger traffic in this section reaches the figure where the bank could expect a return on its investment (Fig. 1).

## 3. ENVIRONMENTAL IMPACT STUDY

It was an important step in the preparatory process to obtain the environmental authorization that was issued with great difficulty due to political skirmishes surrounding the metro, and due to the confused actions of the authorities triggered by the unaccountable protests of green movements. The environmental impact study, conducted parallel with the railway authorization plan, covered all areas of both the building and the final operation, and proved explicitly that a very significant improvement could be expected from the metro in a large area, with respect to environmental effects. Naturally, the main gain is the major journey time saving and the reduction of the surface traffic due to the attractive force of the metro.

A very detailed study was made in the area where the metro would cross the Danube, in the interest of protecting the many thermal springs erupting along the geological fault lines, and the whole karst system. The alignment had to be altered in order to bypass the upthrust that reaches out from the Triassic dolomite mass of Gellért hill under the Danube bed. In this way the structure construction would not approach the dolomite strata that act as the main aquifers of thermal water. The study results affected the construction methods of each station, as well as the vertical alignment.

## 4. RAILWAY AUTHORIZATION PLAN

The essential permission for any metro in Hungary is the railway authorization. This is the stage in a multi-step design

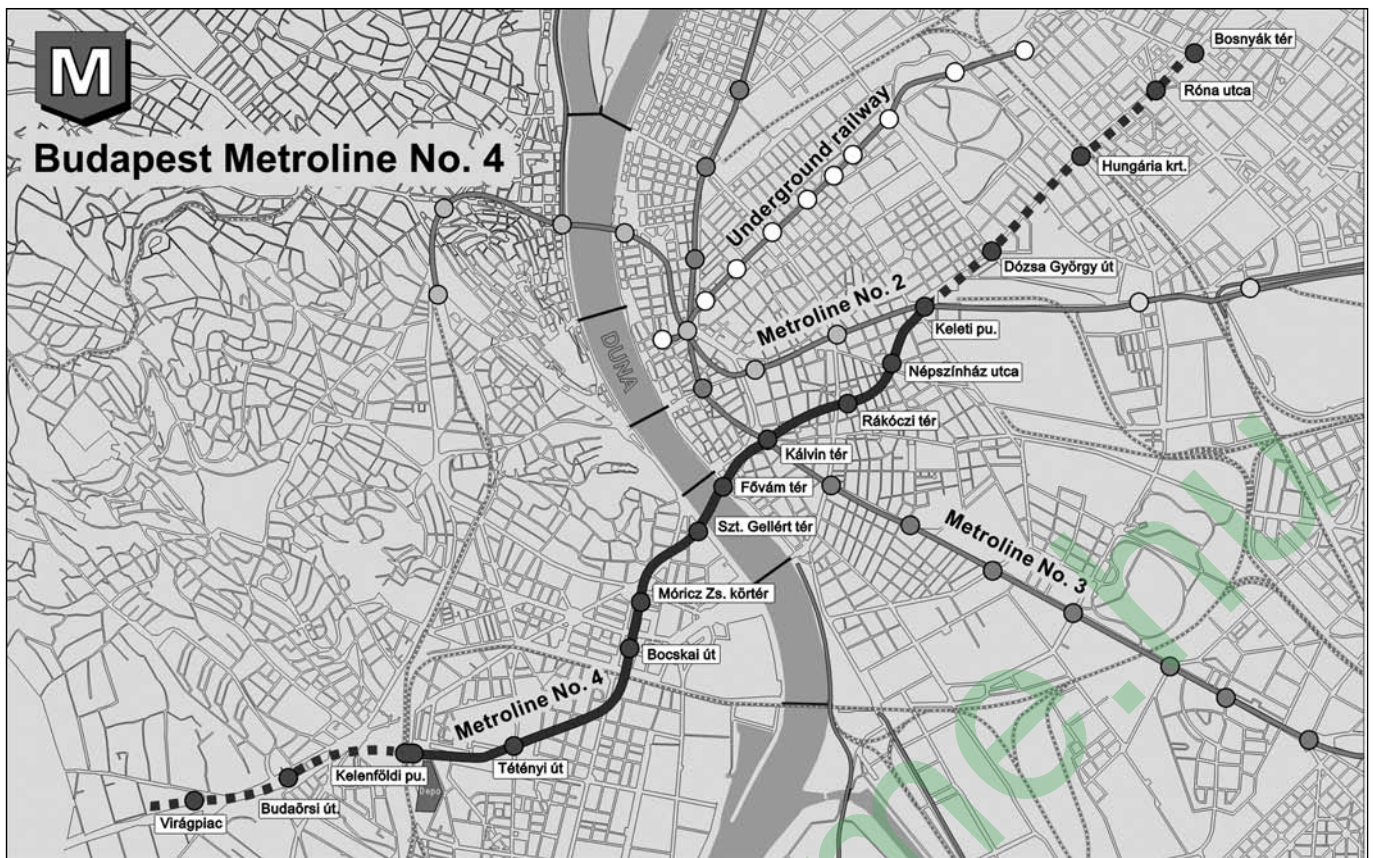

Fig. 1: The Budapest metro lines, Line 4 under construction

and authorization process when the whole system of the metro, all its establishments, apparatus, the order of operation and maintenance are specified and approved in their complexity. In this stage the whole metro line is represented in its entirety, while forthcoming designs can be made separately, even independently, by system or station.

In 1998 a Főmterv Ltd-led consortium won the design tasks of a two-stage international tender, out of 14 bidder. Its members were Főmterv Ltd., Uvaterv Ltd. and the English Mott-Macdonald Ltd. This consortium brought together the experience gained in previous metro buildings in Budapest, general knowledge about the city, the knowledge of the Hungarian civil engineers and the contribution of the English participant, international experience and knowledge.

Metro building has greatly improved recently in the field of tunnel building technology, mainly due to the improvement of cutting edge closed bentonite slurry-shields or earth pressure balance (EPB) shields, and also because of the shotcrete technology (NÖT or NATM, New Austrian Tunnelling Method) that it is widely used internationally, but has been used only once in Hungary. The application of the shotcrete technology was applied both in the tunnel (Fig. 2) and the stations (e. g. Fig. 7). The other field of development in metro building comes as a result of the rapid advancement in electronics, affecting mainly the vehicles and the closely connected train control-command systems, but there are other fields as well.

The main objective of the large metro design team was to build a metro in Budapest that takes into consideration the financial situation of the country at the end of the 20th century but was created for the 21st century Budapest. This strange ambiguity – with many problems to be solved – affects every area of the metro, urging investors, operating companies, designers and authorities to keep considering and revising their viewpoints.

The planning of the surface arrangements and the

construction design of the stations had started during the draw-up of the conceptual system plans. In this way the alignment had been approaching its final layout through continuous correction. Meanwhile, the plans made by the consortium in 1999 had to be modified in places as the result of the environmental authorization process, but it did not affect the essence of the system and the basis of the plans. The plans of many different design areas, designed by numerous designers, were authorized by the Municipal Transport Inspectorate only in 2003, because the environmental authorization was dragged on for such a long time due to irrational demands of civil organizations. The railway authorization entered into force as late as in 2004, due to appeals. The authority determined in the permission the forthcoming design and authorization tasks and some construction tasks as well. The authorization applies to the line, the locations and the structures of the stations and the tracks connecting the depot. It is only possible to depart from these by amending the authorization.

Fig. 2: The the tunnel construction using shotcrete



## 5. PERMISSION PLANS OF THE STATIONS

An architectural tender for the design of the stations was put up following the railway authorization. Its winner, Palatium Ltd. was given the right to continue the architectural design. They had to create a permission plan for the stations and for the surface arrangements, since the railway authorization was a final building permission for the subsurface parts. The stations acquired their final form during the process of the permission plan design. The architectural design was made by Palatium Ltd. and the civil engineering design by Fömterv Ltd. and Uvaterv Ltd. (Symonds et al. 1991, Fömterv et al. 1999, Palatium et al. 2007.)

## 6. ALIGNMENT DESIGN

The exact alignment was principally determined by transport needs, but city planning, geotechnical, environmental, economic aspects were also considered. It was essential that the line should serve an area where public transport is already significant but does not have rapid rail-mounted public transport. The existing public transport goes along an overburdened, bottleneck route, due to the mass of Gellért hill. The public transport of many trams and buses operates in very complicated conditions on the surface. The geotechnical conditions had great influence on the alignment, principally on the vertical alignment which basically determined the building possibilities. It was necessary to correct the preliminary geotechnical borings and the experts' opinions in some critical places, mainly in the Danube bed, because there was not enough data due to difficult boring conditions. One of the main aspects of the longitudinal alignment was to build it as near to the surface as possible because this way the loss of journey time (spent on escalators) could be reduced, and also the cut-and-cover building method for stations would be more economical. However, geotechnical conditions, which are significantly different on the two banks of the Danube, were set against it. The shields can go closer to the surface on the Buda side in the Oligocene soil, but on the Pest side it has to go deeper because of the inferior Miocene soil.

The section of the fixed line, to be built in the first phase, was chosen from many possible alignments and travelling methods. It goes along built-in areas where the existing road system does not allow for a cut-and-cover tunnel building method. The line connecting the stations located at the most important junctions of the area lies almost entirely in curves, but the parameters of the curves enable the trains to travel at an ideal speed everywhere, guaranteeing aspects of travel comfort.

## 7. STATION PLANNING

It was an important factor in the planning of the stations – located at junctions, mainly on squares – that they should be built from the surface, because in this way the mining building method could be avoided. It would have involved great risks with these individual-sized stations and might have led to significant surface settlement. The cut-and-cover method resulted in box station structures of diaphragm walls. The diaphragm walls are the side walls of the stations, but also act as propping for the working pits. Beside diaphragm walls, pile walls that are formed by intersecting piles are also conceivable. The monolithic reinforced concrete slabs leaning on the side walls are the permanent trussing structures of the

walls. In certain stations where the dimensions of the area proved it necessary, trussing structure elements will be built in the open spaces above the passenger area.

In a small number of stations it is not possible to build the entire station with the cut-and-cover method. In these cases a combined structure building technique was suggested. This means that the inclined escalator adits and the largest possible parts of the stations are built with cut-and-cover method, and the rest of the platforms are built with modern shotcrete mining method.

## 8. IMPLEMENTATION OF THE METRO LINE

### 8.1. Tender documentations, putting out to contract

In 2005, after a long year laden with many debates and contradictions, the obstacles to building the metro were removed and realization was given a new impulse. The Fömterv - led consortium - albeit with great delay - was able to start making the tender plans, and the designs had been completed in several phases by 2006 and 2007, only the final track construction tender and depot tender are to be finished in 2008. The tender conditions are according to FIDIC “Yellow Book” which means that the constructors bid on tender documentations, and the winner will have the implementation plans made. This form enables the constructors to have the designs made in accordance with their own technological potentials. However, while this tender technique has advantages, there are several problems, mainly due to the fact that different partial tasks are in the hands of different constructors. The metro is too complex a civil engineering project to allow it to be handled in parts, and assuring agreement is extremely difficult because of different interests. The lack of the uniform handling of the implementation plans results in risks that are manifested in the constructors' prices, and jeopardizes the establishment of the best solution.

Constructors were chosen in an international public procurement tender. European and even Japanese metro building companies applied, in addition to the companies already present in Hungarian construction works.

### 8.2. Tunnel building

The cross section of the tunnel is shown in *Fig. 3*. The “BAMCO” consortium consisting of French, Austrian and Hungarian companies won the tender to build the 7.4-km twin running tunnels. The tunnel-building twin device they operate – made by the German Herrenknecht company – is the so-called earth pressure balance closed-front tunnel shield. Open-front tunnel shields go along in the Buda side soils and they use less compressed air, whereas in Pest, foam-making compounds will be mixed with the soil according to the plans, and it will give real earth pressure balance. The closed-front shield is necessary here, due to the occurrence of much younger water-holding strata, running sand and silt. The use of open-front tunnel shields during the two previous metro constructions resulted in significant ground settlement despite the use of caissons, and the damages could only be repaired within decades. All these can be prevented by conscientious work, the choice of the right technology and disciplined participants. Naturally,

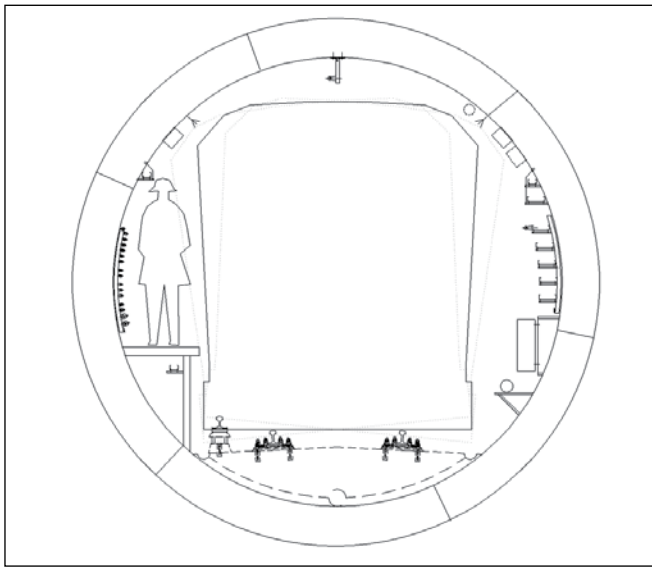

**Fig. 3:** Cross section of the tunnel

safer progression is slower and more expensive and it motivates constructors against safety.

The tunnel boring machine inserts the reinforced concrete tubbing rings that give permanent support. The prefabricated members of five segments create the whole ring. The watertight connection between the members is guaranteed by the precast lining with neoprene gasket seals. Their compression, therefore the adequate sealing, is guaranteed by the support pressure of the progressing shield, and transversely by the wedge-shape of the end ring. Tubbing rings are constructed in steel moulds with fine dimensional tolerance, and the quality of the concrete is continuously monitored. The continuous and precise excavation of the so-called working chamber by screw conveyor is an important part of the technology as its lack or bad quality is the main reason for surface settlement. The working chamber lies between the progressing shield and the tubbing rings that are inserted in under its protection. Surface settlement has to be reckoned with even during careful work, but this figure can be kept low by conscientious work.

The specific task of the shield tunnelling is the complicated logistic task of servicing the shield. A one-metre progress in the tunnel means excavating 28 m<sup>3</sup> of muck per shield, and the daily progress can be as much as 15-20 meters. Consequently, soil transportation can amount to 1900 m<sup>3</sup> of loose muck per day. The number of the 1.5 m-rings can be up to 120 pieces daily, in addition to other materials. The service place for the Buda section is Etele square, and St. Gellért square for the Pest section.

### 8.3. Station construction

At the time of writing this article, all stations' constructions have already started. In compliance with the progress direction of the shield, the construction of the Buda stations has advanced greatly. According to the organization plans, in each case the shield arrive at the structurally completed metro station, and it is drawn along the station up to the other end, where it starts excavating again. The fact that the shields have to be drawn across the stations brought about the geometrical requirement that due to the temporary space requirement of the shields (being much larger than the clearance), the revetment walls that also provide the inner waterproofing of the stations' side walls are installed in later. The final construction of the stations has to be prolonged until the shield service is finished, as the incoming and departing transporting trains

need a smallish shunting yard within the half-finished stations. As regards the box structures with diaphragm walls that are being constructed in the immediate vicinity of buildings, it was important to avoid ground settlement, which is why the great surface loading determined the static design. The diaphragm walls built between the guide walls were constructed on a practically chosen sunk surface level of construction, with the length of one bite depending on the technical equipment of the constructors. The diaphragm walls go deeply under the base slab so that the length of the wall for tie-back underneath should be adequate at the time of the excavation and base slab construction. This way, the ground friction occurring on the diaphragm walls can be reckoned with in the protection against heave. The stability of the diaphragm walls has to be checked in each interim state of soil excavation because it is relevant to the structure elements. Depending on on-site possibilities, the following construction technology is used in some cases: temporary intermediate struts are continuously installed to support the diaphragm walls, according to the excavation. These struts bear solely the horizontal loading until the base slab is completed and their function will only end after the completion of the works proceeding upwards, the supporting slabs and the permanent struts. As regards those stations where it was important to re-establish surface traffic as soon as possible, the so-called "Milan or Top-Down" construction method was used. This means that the roof slab is constructed using formwork placed on the ground, shaped in the first stage of the excavation, then the further excavation and the support system installation is continued under the protection of this slab which acts as a prop. slab, too. The larger parts of the slab floors are monolithic reinforced structures, but wherever it was possible, prefabricated girders were designed. The inner slabs, walls, lift shafts and staircases that sometimes also take part in the outer force interplay are monolithic structures, too.

The waterproofing requirements of the stations are very high, therefore it is not enough to build watertight diaphragm walls on their own, it is necessary to build in an inner waterproofing system as well. The system generally used in underground car parks - that is, the rain water that accidentally enters the waterproof diaphragm walls is collected in an inclined water groove and conveyed into the drainage system - is not an option here, due to the planned 100 year-lifespan of the metro. Constructors use either an inner foil-type liner and the inner support-giving reinforced concrete revetment wall, or an inner revetment wall made waterproof with mass of material. Inner liners serve complex tasks because these large surfaces are to be made visible concrete, and are not provided with further panelling or paint.

The structures enclosed with impermeable waterproofing naturally had to be designed against floatation and heave, as empty box structures are much lighter than the original soil. The protection against heave necessitated the increase of the empty weight besides increasing frictional forces of the diaphragm walls. In order to provide this weight, very thick base slabs are implemented above the waterproofing, and all considerable structure elements are connected so that they act as a whole.

As examples see the ground plan and longitudinal section of Szent Gellért Square station (*Figs. 4 and 5*).

### 8.4. Inner services of the stations, operating systems

In addition to the passenger areas, the operation of the metro requires large-sized operations areas. The operations areas

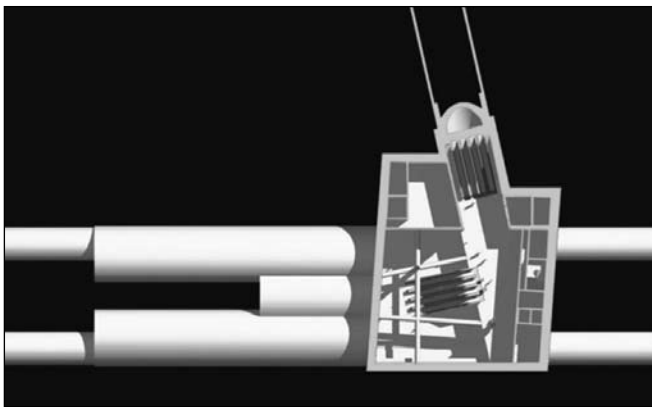

Fig. 4: Ground plan of the Szent Gellért Square station

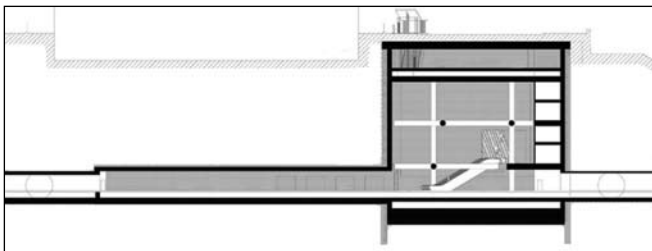

Fig. 5: Longitudinal section of the Szent Gellért Square station

are generally located at either end of the stations, on different levels. Some of the operations areas are constructed for the purpose of housing heavy machinery of significant static loading, therefore static design had specially to take into consideration the escalators, elevators, transformers and large ventilating machines. Planning also had to deal with the delivery route of the heavy machinery because it is relevant both in terms of structural calculation and geometry. The geometry of the inner reinforced concrete structures is often determined by the space requirements of the station's inner services, but sometimes even the large number of the electric cables are relevant in terms of design. Several openings for protective pipes were constructed through the inner slabs and walls for mechanical and electrical systems.

Until the opening-to-traffic of the metro line there are great many equipments to be built in, to commission and harmonise their operation with the other equipments. High quality paving will be built on the surface public areas, as they have to bear heavy pedestrian traffic for a long time. Modern illumination, public address system, surveillance system, track intrusion detection system, high pressure water mist, etc. will make the metro complete.

To display stations under construction some examples are shown. The Tétényi Road station's photograph can be seen in Fig. 6, the Bocskai Road in Fig. 7, and the Móricz Zsigmond Circle in Fig. 8.



Fig. 6: View of the Tétényi Road station under construction

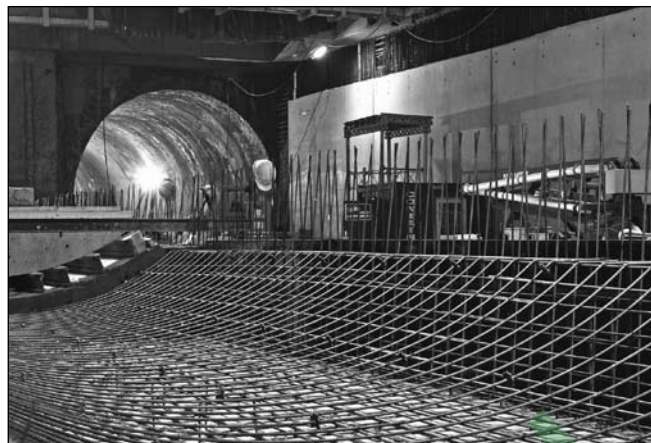

Fig. 7: The Bocskai Road station constructed using shotcrete method



Fig. 8: Internal view of the Móricz Zsigmond Circle station

## 9. CONCLUDING REMARKS

Building the fourth metro line in Budapest is a highly complex civil engineering task. Its implementation - after a long preparatory period and several political skirmishes - has begun at last, and is at an advanced stage. The enormous underground reinforced concrete structures form the backbone of the metro, creating operation areas, where co-designers, including civil and mechanical engineers design their technical equipment.

This article is the first part of a report. The next part will describe the reinforced concrete structures of the metro in detail.

## 10. REFERENCES

- Symonds Travers Morgan – Systra – Főmterv Ltd-led consortium (1991): “Feasibility Study for Budapest Metro Line 4” (In Hungarian) Budapest Főmterv – Uvaterv – Mott MacDonald consortium (1999): “Railway authorization plan for Budapest Metro Line 4” (In Hungarian) Budapest Palatium - Főmterv – Uvaterv (2007): “Permission plan of the stations of Budapest Metro Line 4”: Budapest  
Schulek, J. (2005): “Budapest Metro Line 4 – antecedents, preparation”, *Közúti és Mélyépítési Szemle* 2005/10 (In Hungarian), *Közúti és Mélyépítési Szemle*, pp. 2-12.

János Schulek (1947) certified civil engineer graduated from Technical University of Budapest, Faculty of Civil Engineering 1972, structural engineer 1983. Civil engineer in Főmterv Ltd from 1972, technical director from 1990, president-CEO from 2006. Activity: design of urban structures, general planning, the technical direction of the 300-member engineering office.

# DEVELOPMENT OF THE FI-150 PRECAST CONCRETE BRIDGE GIRDER FAMILY – DESIGN, PRODUCTION AND APPLICATION



Antal Bedics – Gábor Dubróvzsky – Tamás Kovács

*The rapid expansion of the Hungarian public transport network from 2003 delivered the technical claims as well as created the market opportunity to develop a new prestressed, in-plant precast bridge girder family in Hungary. The development of the FI-150 beams was led by functional, geometrical and structural-economical considerations. The beams have been designed according to the structural and durability requirements of both the Hungarian Road Technical Specifications and the Eurocode. The FI beam family is made of C60/75 grade concrete and has a total depth of 1.50 m. The longest element is 44.80 m long that is able to bridge max. 44.20 m long, simple or continuous spans. The first motorway bridge superstructure consisting of 42.80 m long FI beams has been built on the M7 motorway in December 2007.*

**Keywords:** motorway, prestressed concrete, precast bridge girder, durability, high strength concrete, experimental program, design, Eurocode

## 1. INTRODUCTION

### 1.1. Preliminaries

The ambitious conception on the rapid expansion of the Hungarian public transport network resulted in a boom in the Hungarian bridge construction sector from 2003. Significant number of new bridges has been designed as part (flyovers and under-passes) of the M0, M7, M6, M5 and M3 motorways or to make direct or indirect connections between these newly built motorway sections and the existing highway network. From 2003 the number of motorway and highway bridges operated by the State Motorway Management Co. and the Hungarian Roads Management Co. increased by approximately 10% and this increase mostly covered bridges with spans longer than 10 m.

This situation gave possibilities for the participants for intensive product developments on areas where the newly elaborated structural solutions proved functionally or economically more advantageous compared to the previously applied ones. The Ferrobeton Co. has been the main manufacturer of precast concrete bridge girders for many years in Hungary by possessing the appropriate building technical approvals, the necessary moulds and the prestressing capacity for each beam of four frequently used bridge girder families (FP, FCI, FPT, ITG). Based on the experiences coming from the participation in the completion of new motorway sections between 2002 and 2003 the company recognized the market opportunity for producing prefabricated bridge girders in around 44 m length.

### 1.2. Functional demands and their consequences

During the design of motorway bridges, functional, geometrical and structural-economical difficulties have arisen in the near past in Hungary.

There were no real alternatives for the concrete superstructures of 200-250 m long viaducts built above 15-20 m deep valleys. In the absence of competitive structural solutions, such as cable stayed or extradosed constructions, the incrementally launched box girders have been most frequently applied many times in combination with a relatively conservative design. In this situation the question is not only the structural type and the resulting construction cost but the required construction time is also a significant aspect.

Bridging a motorway by flyovers under relatively small angle results in superstructures with high skewness. In these situations the plane of the intermediate support can also not be perpendicular to the longitudinal axis of the bridge that is structurally unfavourable. Additionally for precast concrete superstructures, the high skewness requires wide structural cross beams on the piers to assure the necessary supported length for the beams and, as a consequence, the wide cross beams limit the motorway clearance.

Another functional demand was to design flyovers without any intermediate support in the central reserve between the two carriageways of the motorway in order to improve the visibility for the passengers. This demand became even more intensive from 2006 when the total width of the standardized motorway passage has been reduced from economical points of view. Using the existing sets of prefabricated bridge girders (see their comparison in 1.3), where the length limit is 34.80 m, before 2006 precast concrete superstructures above motorways without intermediate support could not be built in Hungary for geometrical reasons.

### 1.3. Comparison of the existing precast bridge girders

A brief overview on the I and T shaped cross sections of precast concrete bridge girder families suitable for spans longer than 30 m and produced by the Ferrobeton Co. using the traditional Hoyer system can be seen in Fig. 1. Their main data such as



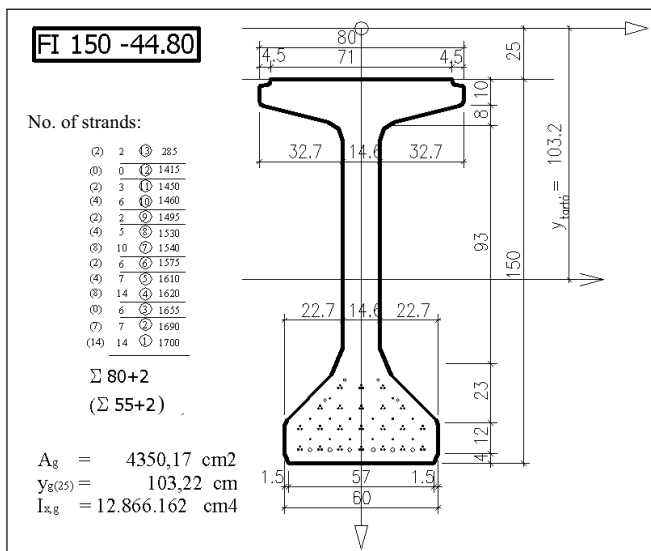

**Fig. 1.** Comparison of the precast bridge girders produced by the Ferrobeton Co.

the total depth, the longest element in the family, the specific weight and the total mass of the longest element are included in *Tab. 1*.

The FP type beams are excluded from the comparison since they are suitable only for short span ( $\leq 15.0$  m) bridges. Both *Fig. 1* and *Tab. 1* are extended by the newly developed FI type family whose detailed introduction and description are found in *Chapter 2*.

The FPT beams are made of C50/60 grade concrete while C40/50 grade concrete is used for the ITG and FCI type beams. Before any improvement it was clearly decided on the basis of data in *Table 1* that the development of a new beam type should be based on the FCI beams considering its cross sectional shape, which is favourable from both manufacturing and maintenance points of view, the total depth and the belonging specific weight as well as the possible improvement in the concrete strength.

## 1.4. Directions for improvement

In 2005, when the Ferrobeton Co. realized that the functional demands described in 1.2 concerning the motorway bridges could be fulfilled by traditional precast concrete superstructures with the application of longer beams and decided to try to take the advantage of this business opportunity, they had to clearly point out both the technical and the strategic directions of product development.

Technically, the more and more severe durability requirements included in the relevant design specifications and applicable for bridge elements was the most important aspect. Previously the precast concrete bridge girders have been usually covered by a multi layer chloride-resisting coating system to prevent the contact between the water spray containing de-icing salt and the beam surface. According to recent researches, the performance of concrete regarding its resistance against chloride attack can be significantly increased by simply applying concrete

with higher concrete strength. As a consequence of this, the application of higher concrete strength makes possible to apply higher prestress, which is the main structural precondition for increasing the beam length.

Another strategic aspect is to base design of the new girder family on the Eurocode. According to the existing legal situation, after 2010 the application of Eurocode must not be ignored in Hungary independently of any other domestic specifications. This applies in the first place for structures to build from governmental investments.

Based on the above considerations, the Ferrobeton Co. decided to use higher concrete grade for the new girders compared to that for the existing girders. This decision was extended by the secondary ambition of omitting the expensive chloride resisting system and assuring the necessary chloride resistance by the concrete itself. The structural design of the new girders have been ordered on the basis of both the Eurocode for future or possible abroad applications and the Hungarian Road Technical Specifications for present domestic applications. Parallel to this program, the company started a significant factory extension in order to be able to fulfil their future and foreseeable orders, in which the new factory buildings and their equipments have been arranged and sized with regard to this new product (see *Chapter 3*).

## 1.5. Laboratory experiments

Up to 2005 the highest concrete grade used for precast bridge girders was C50/60. In 2005 the Ferrobeton Co. (member of the Association of Hungarian Concrete Element Manufacturers) in corporation with the Budapest University of Technology and Economics (BUTE), Department of Structural Engineering carried out a long experimental program on applying high strength concrete in prestressed bridge girders with the financial support of the Hungarian Company of Road and Technical Information (ÁKMI Kht.). The target strength was C70/85. This program focused in the first place on the appropriate placing of concrete into the formwork and its proper compaction instead of the simple production with the intended strength. The latter was not a big challenge at that time. Many laboratory tests have been carried out using minimum two different alternatives for many concrete components such as CEM I 52.5 and 42.5 cements, natural, river gravel and crushed basalt as aggregate as well as silica fume and limestone as additives. During the sample tests a maximum concrete strength of C90/105 has been reached.

This program ended by full-scale failure tests on 8.8 m long simply supported FPT beams (*Fig. 2*). The aim of these tests was to compare the structural behaviour of beams with the same geometrical sizes and support conditions but having a concrete strength of C50/60 and C90/105. The results justified the expected behaviour and the previous calculations while no structural disadvantage arising from the application of high concrete strength could be observed. The ductility of beams made of C90/105 concrete remained significant, the maximum midspan deflection due to two symmetric concentrated loads

**Table 1.** Main characteristics of the precast bridge girders produced by the Ferrobeton Co.

Beam type	Total depth [cm]	Max. length [m]	Specific weight [kN/m]	Total mass of the longest beam [t]
FPT	130	34.80	11.278	39.2
ITG	110	32.80	8.323	27.3
FCI	120	32.80	8.875	29.1
<b>FI</b>	<b>150</b>	<b>44.80</b>	<b>12.617</b>	<b>56.5</b>

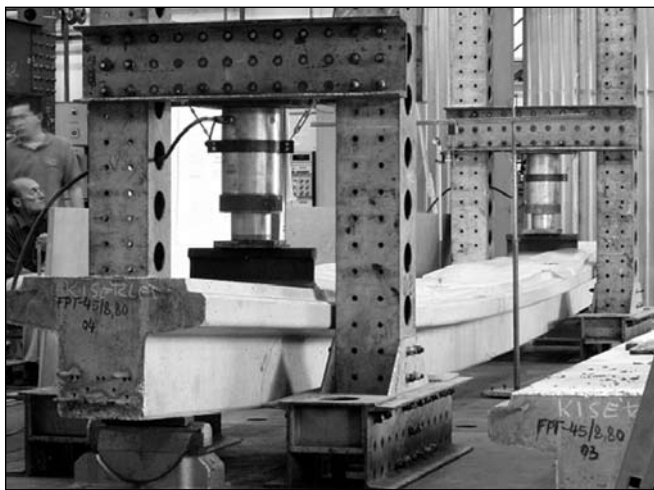

**Fig. 2.** Bending failure of the test FPT beam made of C90/105 grade concrete

as shown in *Fig. 2* was higher than 1/30-th of the span in each case.

As a result of this program, by 2006 the factory was ready to continuously produce precast bridge girders from C60/75 grade concrete. The concrete technological measures and the concrete plant inside the factory has been improved and became able to operate on this level.

## 2. STRUCTURAL DESIGN

For reasons detailed in *1.4*, the structural design of the new girder family has been based on both the Hungarian Road Technical Specifications and the Eurocode. The design

according to the Hungarian Road Technical Specifications and the product plans have been carried out by the Uvater Co. while the Eurocode based design has been completed by an independent organisation. The Budapest University of Technology and Economics, Dept. of Structural Engineering has been responsible for the supervision of the structural design.

During the full design process the Eurocode-based design governed the determination of the changeable design variables.

### 2.1. Design standards

The design according to the Hungarian Road Technical Specifications was necessary for legal reasons. In present days the application of these specifications are obligatory for structures that are part of the Hungarian public transport network and are under governmental management. This design assures the domestic applicability of the beams from legal side.

The Eurocode-based design was necessary for strategic reasons as well as for the possible applicability of girders beyond the Hungarian border. From 2002 the Eurocode standards may be applied parallel to the existing national standards. For bridges in Hungary, this parallel application does not work due to the obligatory status of the Hungarian Road Technical Specifications. According to the schedule for the harmonization of the standards inside Europe, the Eurocodes will come in force in 2010 at the latest and all conflicting national standards must be withdrawn at that time. Beyond 2010 the application of Eurocodes – mainly for projects having governmental invest - must not be disregarded from legal point of view.

### 2.2. Compressive strength of concrete

According to the design calculations, significant amount of prestress is necessary to this product for structural reasons, which requires relatively high concrete strength both for the final stages and even at the time of stress release. Both the intended higher durability and this higher prestress jointly resulted in the application of the C60/75 strength class. The first difficulty in the design process was the way of consideration of the C60/75 concrete strength and its consequences in the calculations.

The relevant Hungarian Road Technical Specification does not deal with concrete strength classes above C55/67.

**Table 2.** Extension of the Hungarian specification by the strength class C60/75

Stress limit	Strength class									Formula	C60/75
	C16/20	C20/25	C25/30	C30/37	C35/45	C40/50	C45/55	C50/60	C55/67		
pure compression $\sigma_{beN}$	9.6	12.0	15.0	18.0	21.0	24.0	27.0	30.0	33.0	$0.6R_{bk}$	36.0
flexural compression $\sigma_{beM}$	11.5	14.4	18.0	21.6	25.2	28.8	32.4	36.0	39.6	$1.2\sigma_{beN}$	43.2
flexural tension $\sigma_{beH}$	1.16	1.42	1.58	1.75	1.92	2.0	2.16	2.33	2.50	$\sigma_{hH}/1.2$	2.60
principal tensile stress $\sigma_{beF}$	1.4	1.7	1.9	2.1	2.3	2.4	2.6	2.8	3.0	$\sigma_{hH}$	3.1

However, it contains the calculation formulae for all strengths parameters and compressive stress limits. Therefore, in order to be able to consider the C60/75 strength class, the relevant tables containing concrete strength and stress limits had to be extended with the strength class C60/75 by extrapolating values using the existing expressions. The result procedure for the concrete stress limits is shown in *Tab. 2*.

Similar but not the same problem has arisen in case of the Eurocode-based design. In the time of design the adopted Hungarian version of the relevant Eurocode was not equipped by national annex and so no nationally determined parameter have been fixed. On the other hand, based on the significant amount of experiences of the company in manufacturing precast prestressed products, the applied compressive stresses for concrete at the time of stress release have been significantly higher ( $0.6-0.9f_{ck}(t)$ ) than the recommended value of the relevant stress limit ( $0.7f_{ck}(t)$ ) in the Eurocode. Thus, referring to the previous experiences, the quality control measures established for the full manufacturing process of this product and the severe requirements laid in the relevant certificate of acceptance, a compressive stress limit of  $0.9f_{ck}(t)$  for concrete at the time of stress release has been accepted and applied in the design calculations. Even the first elements have clearly shown that no unfavourable sign (e.g. local failures, longitudinal cracks, etc.) could be observed due to this stress limit increase.

Another consequence of applying high prestress for the beams is the distributed anchorage of tendons along the max. 10 m long parts of the beam ends. The possible total number of 80 strands in the bottom flange would not have been resisted simply by the concrete section with its strength so the tendons had to be divided into groups and anchored in groups in four different positions at the beam ends. In *Fig. 3* the axial stresses at the (bottom) extreme fibre of the beam due to the prestress and the self-weight of the beam can be seen along the full beam length. The first sketch simply shows the effect of prestress. The steps in the normal (compressive) stress diagram are situated at the different anchorage points. After lifting the beam out of the formwork and the full self-weight (second sketch) acts, the typical saw tooth-shaped concrete compressive stress diagram develops at the bottom flange of the beam (third sketch).

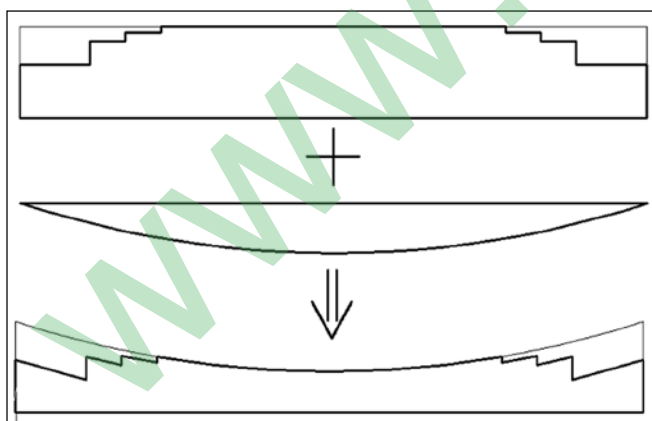

**Fig. 3.** The effect of partial unbonding on the concrete compressive stresses

This gradual release of prestress has been technologically solved by unbonding the required number of strands (or bundles of strands) along the required length by fixing plastic hoses around them before concreting (see *Fig. 4*). After stress release the unbonded parts of the relevant tendons can not be removed but they will be completely closed and isolated from environmental effects by monolithic cross-girders in the final stage of the bridge.

## 2.3. Geometrical design

The main geometrical dimensions of the new FI type beam family have been selected to fulfil the functional demands detailed in 1.2 as well as the geometrical and weight limits depending on the new manufacturing equipment and the existing transport possibilities (e.g. min. radius of curvature for both highway and railway transport, axle and wheel load limits for highway transport, limited clearance width for railway transport, etc.).

As a result of this, the length of the longest element in the family has been chosen to 44.80 m assuming  $2 \times 0.3$  m support width at the ends. Consequently, the longest beam is able to bridge max. 44.20 m simply supported or continuous spans as part of usual highway bridges. The minimum beam depth belonging to the above maximum length - considering highway bridge applications - resulted in 1.50 m according to the Eurocode-based design.

The cross sectional shape has been determined on the basis of considerations written in 1.3 and the maximum lifting capacity available at the factory, during transport and on-site. The shape is originated from the existing FCI beams because its shape proved to be the most favourable from the point of view of the workability and the compactibility of concrete. In order to achieve the intended high concrete strength even in the bottom flange, the compactness of concrete and consequently the minimum amount of air in the fresh concrete after compacting has a crucial importance. Therefore, the higher the angle of the lateral face parts of the cross section, which require counter formwork, to the horizontal plane the easier the way of air forced out of concrete by external formwork vibrators is. As a result of this consideration, the angle of the upper face of the bottom flange to the horizontal plane has been selected to not smaller than  $45^\circ$  as shown in *Fig. 1*. The inclusion of the considerable number of strands into the bottom flange and the required safety against lateral buckling during lifting and moving of the beam (see 2.5.1) made necessary relatively wide flanges that resulted in a typical I shaped cross section.

## 2.4. Optimization of the design variables

In designing the individual beams as part of a usual, partly prefabricated superstructure, the following design variables, which, theoretically, can be altered in each case, had to be fixed:

- the distance between axes of beams assuming parallel beam arrangement on the substructures,
- the number of strands in the individual beams that determines the total amount of prestress,
- the positions of cross sections at which the anchorage of groups of partially unbonded tendons begins (anchorage sections).

The distance between axes of beams had to be limited from below for maintenance reasons. The accessibility of side faces of beams, which is a maintaining demand established by the operating company, is physically possible if the distance between beam axes is not smaller then 1.0 m. In this case the clear distance between the adjacent bottom flanges results in 0.4 m.

In general cases the minimum amount of prestress is structurally governed by the decompression criterion at the midspan for simply supported spans (see 2.5.2). The structurally necessary, minimum but geometrically maximum

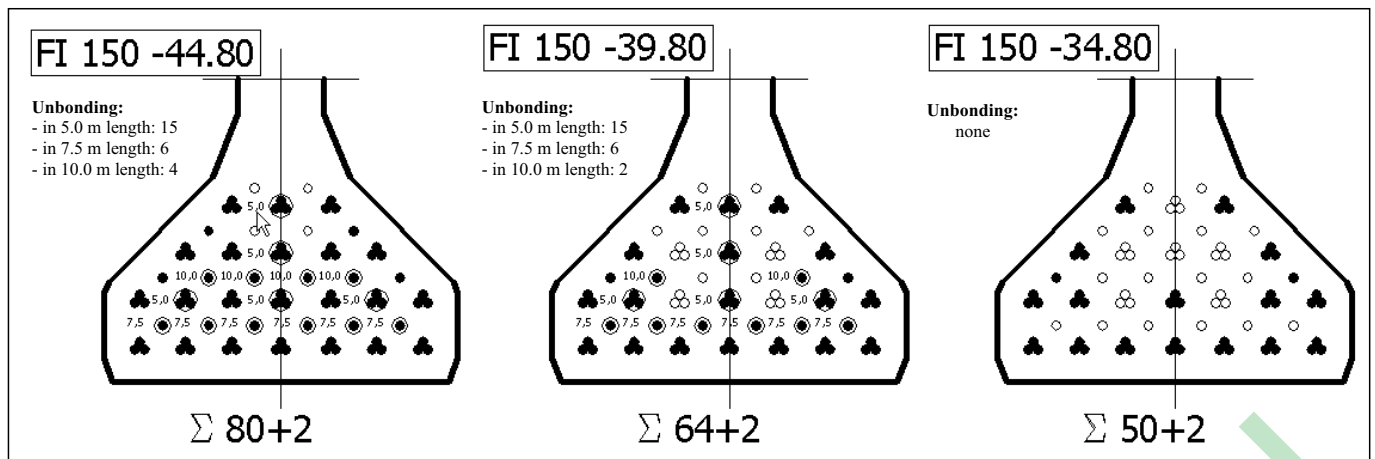

Fig. 4.: The applied three different strand arrangements and the maximum number of strands

number of strands in the bottom flange derived from this criterion applied to the longest beam. This number of strands (80) geometrically determined the area of the bottom flange taking also into account the applied strength class of concrete and the geometrical dimensions of the anchor blocks in the factory.

The number of the partially unbonded strands as well as the lengths of the unbonded parts of these strands has been generally governed by the compressive strength of concrete at time of stress release. Based on these structural and other practical considerations three groups of strands have been selected as partially unbonded. The unbonded lengths measured from the beam ends are 5.0 m, 7.5 m and 10.0 m for the first, second and third groups respectively. These groups include 15, 6 and 4 strands respectively as shown in Fig. 4.

Different values of the above design variables may result in unacceptable number of different cases that would be unfavourable from the point of view of the design. At the same time these variables made possible an optimization in order to minimize the different beam types from manufacturing and design points of view, to provide a useful guide for designers for preliminary design and to find out an efficient and refined structural solution. Finally three different strand arrangements have been fixed which can be seen in Fig. 4. For beams with length up to 34.80 m 50+2 strands (50 in the bottom flange and 2 in the top flange) are applied without unbonding. For beams with length above 34.80 m 64+2 strands are applied up to 39.80 m and 80+2 strands are applied above 39.80 m with three groups of partially unbonded tendons. As an additional guide, recommended distances between beam axes have been elaborated starting from 1.10 m up to 1.70 m and included in the relevant building technical approval.

## 2.5. Design verifications

In framework of the structural design the following transient and persistent design situations, which can be critical during the manufacturing process, the transport, the on-site assembly and the final stages of beams, have been verified in the relevant limit states according to both the Eurocode and the Hungarian Road Technical Specification:

- transient design situations
  - the stage of stress release ( $t_0$ )
  - lifting the beam out of formwork ( $t_{01}$ )
  - transporting the beam out of factory
  - on-site assembly ( $t_1$ )
- persistent design situations
  - final stage of beams ( $t_\infty$ )

During the Eurocode-based design XD3 and XF2 exposure classes have been assumed for the beams operating in their final positions in persistent design situations.

In verifying the serviceability limit states according to the Eurocode, adequate quality control and careful manufacturing process has been considered, and consequently, the characteristic value of the prestressing force ( $P_k$ ) has been taken as the mean value of prestress ( $P_k = P_m$ ) in transient design situations. However, in persistent design situations a lower ( $P_{k,sup} = r_{k,inf} P_m$ ) and an upper ( $P_{k,inf} = r_{k,sup} P_m$ ) characteristic value have been calculated and applied where  $r_{k,inf}$  and  $r_{k,sup}$  has been taken as 0.9 and 1.1 respectively.

### 2.5.1. Transient design situations

The time of stress release ( $t_0$ ) has been assumed to be controlled by the concrete strength measured on standardized 150×150×150 mm sample cubes. The mean strength has to achieve 50 N/mm<sup>2</sup> up to 34.80 m beam length, 55 N/mm<sup>2</sup> between 34.80 m and 39.80 m lengths and 67 N/mm<sup>2</sup> above 39.80 m lengths. The time of lifting the beam out of formwork ( $t_{01} = t_0$ ) has been assumed to be the same as for that of stress release. The age of beams has been assumed to 7 days at the time of transporting them out of factory, and  $t_1 = 100$  days at the time of on-site assembly. Regarding the dynamic effects during moving and transport dynamic amplification factors equal to 1.5 as a maximum value and 1.0 as a minimum value have been taken into account for the self-weight of the beam.

In verifying the transient design situations, stress limitation regarding the compressive stress in the concrete and the tensile stress in the prestressing steel has been carried out along the anchorage zone in the bottom flange as well as at the midspan cross-section. Fig. 5 shows the maximum concrete compressive stress in the bottom extreme fibre of the last anchorage cross-section (the first cross section measured from the beam end where the full prestressing is active) according to the Eurocode for the 44.80 m long FI beam. The values relate to the time immediately after stress release ( $t_1$ ), the time of lifting the beam out of formwork ( $t_{01}$ ), the time of on-site assembly ( $t_1$ ; before (a) and after (b) placing the beam into its final position, immediately after casting the monolithic slab (c)) and the final stage ( $t_\infty$ ; after all losses of prestress and time-dependent effects) of the beam. Based on Fig. 5 it is clear, that the highest compressive stress in concrete occurs during the early phases of the manufacturing process, and then this stress gradually and significantly decreases by the time when the beam is placed into its on-site final position and its normal use begins.

Additional verifications in the relevant transient design situations have been carried out such as verification of the

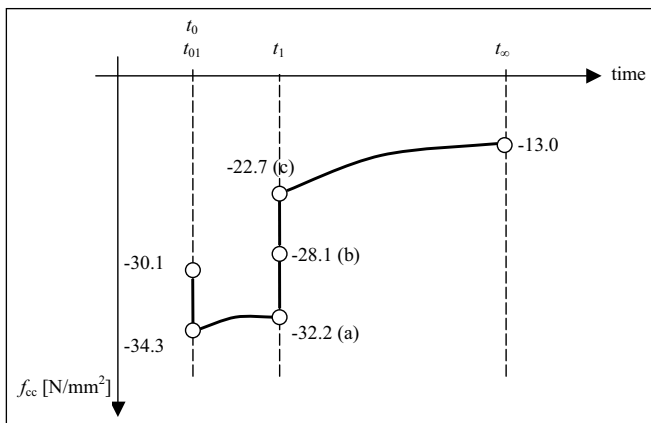

**Fig. 5:** Maximum concrete compressive stress at the bottom extreme fibre at different times

beam against lateral instability, verification of the beam ends against splitting due to prestressing force and verification of the lifting hooks and their connection zone in the beam for crack limitation.

The lateral stability of the longest beam has been verified on the basis of a lateral geometrical imperfection equal to  $L/300$  in the top flange, where  $L$  means the length of the beam.

The longest beam has a total mass of 56.5 t, which can be moved by crane trucks inside and outside the factory. Usually the hoisting of elements is carried out simultaneously on both ends by two independent cranes using vertical lifting cables but the beams have been designed to resist against lifting from one point using lifting cables with minimum inclination of  $60^\circ$  to the horizontal plane. The hoisting load is applied to the beam ends through two lifting hooks (four hooks per beam) for beams longer than 34.80 m. In these cases a spreader beam distributes the lifting force among the two hooks. For beams not longer than 34.80 m only one lifting hook is applied at the beams ends (two hooks per beam).

### 2.5.2. Persistent design situations

In persistent design situation the final stage of the beam as part of the completed superstructure has been verified in the relevant ultimate and serviceability limit states. The flexural and shear capacity of the beam, the shear capacity between the beam and the monolithic slab as well as the adequate safety against brittle failure have been verified as ultimate limit states. In verifying the relevant serviceability limit states, the following checks have been performed according to the Eurocode:

- compressive stress limitation in concrete ( $\sigma_c \leq 0.45f_{ck}$ ) under the quasi-permanent level of actions in order to justify the applicability of the linear creep law;
- normal stress limitation in concrete ( $\sigma_c \leq 0.6f_{ck}$ ) and prestressing steel ( $\sigma_p \leq 0.75f_{pk}$ ) under the characteristic level of actions in order to avoid excessive longitudinal cracking in the concrete and inelastic strain in the prestressing steel;
- crack limitation by assuring decompression under the frequent level of actions;
- deflection control in order to avoid unacceptable appearance of the structure and travel discomfort for users.

The shear design according to the Eurocode has been carried out on the basis of the variable strut inclination method. The angle of the inclined compressive struts to the longitudinal axis of the beam has been chosen to  $35.5^\circ$  ( $\cot\theta=1.4$ ) in order to equalize the  $V_{Ed}/V_{Rd}$  and the  $V_{Ed,max}/V_{Rd,max}$  ratios, that formally results in the same design reserves in the design shear reinforcement and against crushing of the compressive struts.

The total amount of prestress has been generally determined on the basis of the decompression condition for each beam.

In carrying out the deflection control, maximum deflection under the quasi-permanent level of actions regarding the appearance of the structure as well as maximum deflection under the traffic loads itself has been limited to  $L/500$  and  $L/400$  respectively where  $L$  means the span. For simply supported spans built from 44.80 m long beams, the first deflection control proved to be critical.

The adequacy of the longest beam in each group, in which the same prestress at the bottom flange has been applied to all beams (see 2.4), has been verified for both simple and continuous spans. The continuous structures have been assumed to have two spans with the same length. For the continuous structures the necessary amount of reinforcement above the intermediate support has been determined in the monolithic slab and the beam ends connecting to the intermediate support have been checked for the additional compressive stress coming from the continuity. In order to simplify the design and the organization of the manufacturing, for beams as part of a simple span superstructure and the same beams as part of a continuous superstructure the same amount of prestress have been assumed in spite of the possibility for reducing the prestress due to the governing decompression criteria in the beams built in continuous structures compared to that in simple span structures. This reserve may be utilized in case of individual design of beams for continuous superstructures.

## 3. MANUFACTURING

From 1994 the Ferrobeton Co. has been the biggest subcontractor delivering bridge girders for the bridge constructions on the Hungarian motorways (M1, M15, M0/II/A, M5, M3, M7, M6, M60). Thanks to the effective cooperation between the company and its design partners many bridge girder family (with span range between 2.0 and 34.0 m) have been developed and approved by the relevant authority during this period. These different types of beams (FP, FCI, FPT, ITG), which have been manufactured basically at the Dunaújváros unit of the Ferrobeton Co., have been built in more than 600 bridge superstructures in Hungary, most of them have been motorway bridges.

### 3.1. Data on the factory and its manufacturing capacity

The Dunaújváros unit has excellent conditions to realize significant number of bridge projects and, due to this favourable situation, the factory is able to completely carry out the manufacturing and the belonging transport and organization working processes.

The factory is situated on a 25 ha. land area. Large parts of this area can be managed by crane trucks. Manufacturing processes take place only in factory buildings.

The bending of reinforcement bars and meshes is made by special machines. The reinforcement cage (Fig. 6) placed in the beams and made partly of welded fabrics is fully produced inside the factory by its own capacity.

Up to 2004 8 prestressing beds (each having 100 m length) have been able for producing high performance bridge girders in maximum 34.8 m length. Regarding the new capacity demands from 2004 (see 1.1) and the decision of producing new FI beams in maximum 44.80 m length, the company



**Fig. 6:** A part of the reinforcement cage with two lifting hooks at the FI-150 beam end

extended its capacity with a new, 3000 m<sup>2</sup> area factory building in 2004. This new building, which has a direct connection with the concrete plant, includes 6 prestressing beds with a length of 100 m and 2 similar beds with a length of 110 m. The belonging anchor blocks are able to carry prestressing force up to 10000 kN. The building is also equipped by two, wireless controlled, 300 kN capacity bridge cranes, by which the factory is able to produce bridge girders in maximum 600 kN of self-weight from 2004 (Fig. 7).



**Fig. 7:** Moving the FI-150 beam out of the factory building

The possibility for heat-curing of young concrete is available in each factory building. During this process a tempering of the adjacent air in the close surrounding of beams under a plastic film cover is applied. The required steam supplying and transporting network is fully installed.

### 3.2. Concrete plant

The computer-controlled concrete plant consists of two independent parts installed next to each other. Each of them is equipped by a 2 m<sup>3</sup> capacity operating mixer as well as a 1 m<sup>3</sup> capacity reserve mixer. The operating conditions are fully winterized. The aggregate is stored in 18 concrete bunkers in which approximately 2000 t environmental-protected storage capacity is available.

From technological point of view the parallel handling of the special crushed basalt aggregate beside the usual sand and gravel aggregate was fully solved during the manufacturing process of the FI-150 beams.

## 4. APPLICATION

The first precast motorway bridge superstructure made of 42.80 m long FI-150 beams has been built in the Balatonkeresztúr-Nagykanizsa section of the M7 motorway in December 2007. The Ferrobeton Co. participated in this bridge project as the subcontractor of the Lavinamix Ltd.. The main contractor of the concerned motorway section was the Porr Building Ltd. The on-site lifting work was carried out by the Tamás és Zsolt Ltd. on behalf on the Ferrobeton Co..

This simple span motorway bridge consists of two independent superstructures supported by independent substructures for geometrical reasons (Fig. 8). Each superstructure includes 12 42.80 m long FI-150 beams.

For the 42.80 m long FI-150 beams produced for the Z15 bridge the specified 67 N/mm<sup>2</sup> concrete compressive strength at stress release (see 2.5.1) could be achieved approximately 36-40 hours after concreting.

All the technical requirements related to precast bridge girder products according to the relevant building technical approval regarding the concrete strength, the surface characteristics, the curvatures in the vertical (camber) as well as the horizontal plane after removing the formwork have been fulfilled. The quality certificate of these beam products has been based on the tests made by the own quality control unit of the factory, the Budapest University of Technology, Dept. of Construction Materials and Engineering Geology as an invited independent quality controller as well as The Győr Laboratory of the Hungarian Roads Management Co. as the quality control unit of the relevant authority issuing the building technical approvals for bridge projects in Hungary.

After the formwork had been removed, the beams were moved out of the factory building with high capacity trailers to the storage area inside the factory yard (Fig. 7). The lifting



**Fig. 8:** The superstructure of the Z15 bridge under construction



**Fig. 9:** The abutment and the beam ends

of beams during moving inside the factory as well as their charging on to the railway wagons using the private industrial track of the factory has been carried out by high performance crane trucks. For the railway transport of beams special bogie trucks have been used without any restriction to the normal railway traffic.

The discharging of the railway wagons at the target railway station near the building site, the highway transport of beams between the target railway station and the building site as well as the lifting of beams on-site have also been carried out by high capacity trailers. On the building site, temporary access roads with appropriate vertical and horizontal layouts have been arranged. The placing of beams into their final position has been carried out by the parallel use of a 140 t and a 400 t capacity crane truck.

In order to avoid unexpected difficulties during transport and moving of these long and heavy FI-150 beams the Ferrobeton Co. deems necessary to elaborate detailed organization plan regarding especially the local site transport, the geometrical parameters of the target railway station and the geometrical and weight capacity of the highway transport route between the target railway station and the construction site. Therefore, the company strongly recommends for its partners to perform a preliminary site inspection early in the design phase of bridges, for which the application of long (between 32.80 m and 44.80 m length) and heavy bridge girders arises. The company offers to undertake this task carefully investigating the transportability and the movability of beams to be used.

## 5. SUMMARY

In 2006 the Ferrobeton Co. collaborating with the Uvater Co. (designer) and the Budapest University of Technology and Economics (supervisor) put a completely new prestressed bridge girder family on the market that was able to fulfil the functional demands arisen in motorway bridge design in the

near past in Hungary. This FI beam family is made of C60/75 grade concrete and has a total depth of 1.50 m. The longest element is 44.80 m long, which has a total mass of 56.5 t and able to bridge max. 44.20 m simply supported or continuous span as part of a highway bridge. The transportability is possible by railway without restrictions and by high capacity trailers with temporary traffic disturbance. The design requirements have been verified based on both the Hungarian Standard and the Eurocode. The first precast motorway bridge superstructure made of 42.80 m long FI beams has been built in the M7 motorway (near Nagykanizsa) in December 2007.

## 6. ACKNOWLEDGEMENT

The experimental program mentioned in 1.5 was financially supported by the Hungarian Company of Road and Technical Information (ÁKMI Kht.), which significantly contributed to the success of this product development. The authors thanks for this support.

**Antal Bedics** (1959) civil engineer, between 1983 and 1998 employed as structural designer. From 1998 he has been working as the deputy manager at the bridge department as well as the member of the management at the Uvater Co.. From 1988 he has been working on the design of precast, prestressed bridge girders and superstructures made of these beams. Member of the management at the Bridge Department of the Chamber of Engineers (Hungary).

**Gábor Dubróvsky** (1958) civil engineer, between 1982 and 1986 employed as structural designer. From 1987 employed in leading positions at prefabrication companies. From 1994 he has been working at the Ferrobeton Co. as director, currently as deputy managing director. From 1994 he has led the bridge girder development and the enterprise department at the Ferrobeton Co.

**Tamás Kovács** (1974) civil engineer, assistant professor at the Department of Structural Engineering, Budapest University of Technology and Economics. Research fields: assessment of damage on concrete structures by dynamic characteristics, strengthening of concrete bridges, standardization. Secretary of the Hungarian Group of *fib*.

# VIADUCTS BUILT USING INCREMENTAL LAUNCHING METHOD ON THE M7 MOTORWAY IN HUNGARY



András Lontai - András Nagy - Tamás Mihalek

*At the 34.3 km long section of the M7 motorway between Zamárdi, Balatonszárszó and Ordacsehi, a number of bridges were built ranging from simple pipe culverts through overpasses and underpasses with monolithic and precast girders to box type prestressed concrete bridges stretching over small valleys. This article gives a brief information on the latter.*

**Keywords:** incremental launching method, launching nose, piers, central prestressing, free cables

## 1. INTRODUCTION

At the Balaton section of the M7 motorway, in addition to the 1870 m long Kőröshegy viaduct built using free cantilevering method, four small viaducts were also built using incremental launching method. At the section between Balatonszárszó and Ordacsehi handed over in 2005, two viaducts - S16 and S27 were built (Fig. 1). At the section between Zamárdi and Balatonszárszó completed in 2007, also two viaducts - S7 and S14 - were built.

## 2. A BRIEF DESCRIPTION OF INCREMENTAL LAUNCHING CONSTRUCTION TECHNOLOGY

For this construction method, a constructing deck is formed behind one of the abutments (Fig. 2). Here, a formwork conforming to

the superstructure geometry is built. Each concreting unit of the bridge is produced in that formwork and a jack is used to deliver it to final position. While the superstructure slides from the casting yard to final position, each cross section will have a position when it is over a support but also a position when it is in the middle of a field. So, prestressing is applied in the lower and upper reinforced concrete slabs so that it should be compliant for both negative and positive moment. The tendons are positioned in such a way that the resultant of prestressing force should appear in the centre of gravity of the cross section.

An important component of technology is represented by the launching nose. This is a steel structure which is attached to the first bridge unit. Steelwork has a smaller dead weight as compared to the reinforced concrete bridge, so the moments generated at the front of the bridge structure can be reduced during the incremental launching procedure. When the bridge has attained its final position, the nose needs to be removed.

The length of each construction unit is generally half of the

**Fig. 1:** S16 viaduct – completed





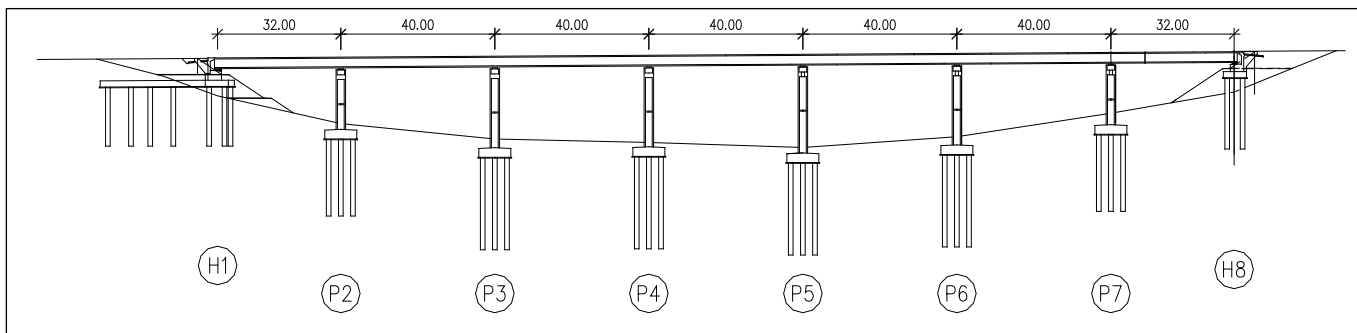

Fig. 3: S16 bridge – Side elevation



Fig. 2: Constructing deck and launching nose for viaduct S16

span length. The application of incremental launching method offers the advantage that the same procedure is repeated many times, so it can be easily organized. The time of construction of one unit may take 7 days.

The substructures must also be prepared for such technology. At the place of shoe blocks, bearings must be prepared. A teflon plate is found atop the bearings, allowing the bridge to slide over it in response to the pushing force while relying on the vertical loads.

### 3. S7, S14 AND S16 VIADUCTS

#### 3.1. General bridge specifications

All of the three bridges have the same constructional system. The right and left hand side carriageways of the motorway are led through the valley by an independently built single cell prestressed concrete superstructure (Fig. 3). Table 1 gives a summary of key data for the valley bridges.

#### 3.2. Foundation

For the bridges, the foundation for the abutments and the piers were made using bored reinforced concrete piles with a diameter of 1200 mm. The composite action of piles is provided by reinforced concrete tie-beams. The final length of piles were finalized after obtaining the results from test loads.

Table 1: Viaduct specifications

Name	Length [m]	Span [m]	Width [m]	Structural depth [m]	Route	Alignment
S7	166	17+3x36+19	14.38	2.5	straight	2.5%
S14	304	32+6x40+32	16.15	2.8	3000 m left curve	2.4 %
S16	264	32+5x40+32	16.15	2.8	straight	0.6%

### 3.3. Substructure

At both ends of the bridge, the abutment design is different due to the mounting technology. As concerns incremental launching technology, it is safer to push it upwards because in such case there is no risk of the bridge starting to move down the slope. So, the construction deck and the incremental launching support are built at the lower abutment. The fixed supports of bridges are also found at that abutment because in such case the piles of constructing deck could also be used to absorb horizontal forces in final state.

The bridge piers are also of single cell reinforced concrete structure. When designing the cap beam of piers the room demand due to the technology must also be reckoned with. The slides must be installed here during the incremental launching operation and room must be provided for the jacks operated when placing it on the shoe.

### 3.4. Superstructure

Superstructures are single cell prestressed concrete continuous box girders. The carriageways have a transversal slope of 2.5%. The superstructure is divided to production units longitudinally, according to the construction technology (Fig. 4).

For stresses occurring during the installation, in the lower and upper slabs, parallel 15 prestressing strands were used, whereas for the final state stresses, external prestressing was applied using four pieces of VTCMM 04-150 double-extruded wires.



Fig. 4: S16 viaduct – Cross section

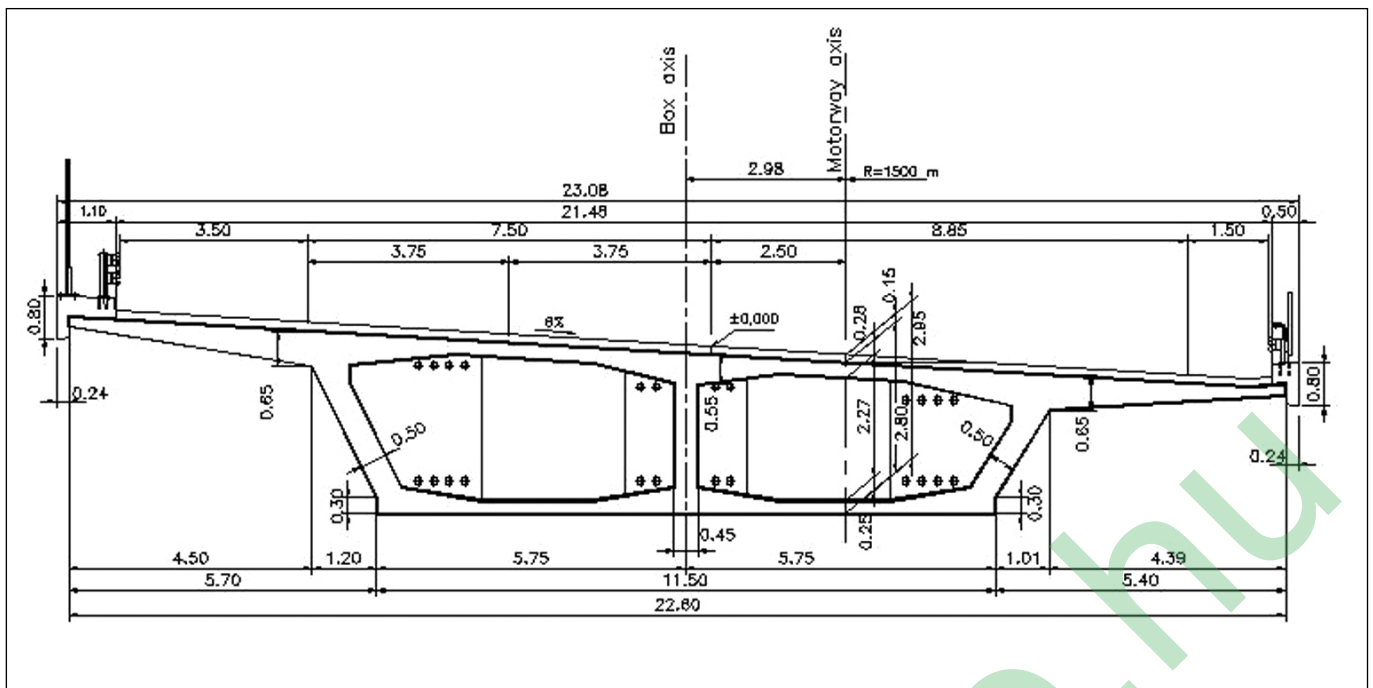

Fig. 5: S27 viaduct – Cross section

## 4. VIADUCT S27

### 4.1. General information

At the viaduct S27 two separated structures were built close beside each other for the opposite road traffics. The cross sections of the superstructures are different. The axis of the motorway is positioned in the horizontal radius of 1500 m and the vertical radius of 25000 m. The selected launching curve is a helix rotated in space around the straight line through the abutment axis.

According to the design speed of the motorway the transversal slope of the structure is 6%. Because of the applied horizontal radius and for driving security reasons and requirements widened superstructure had to be designed. The widths of the two bridges are 23.08 and 23.58 m.

The spans are 32.0+3x40.0+32.0 m, the total length is 184 m. The axes of the piers are positioned in radial direction. The superstructures are two-cell prestressed concrete box girder, the depth of the box is 2.80 m (Fig. 5).

### 4.2. Foundation

The viaduct has four piers and two abutments. They have deep foundation with large diameter bored piles made by Soil-Mec technology. At the abutments 2x10 and 2x14 piles with dia 1200 mm were constructed, with the length of 28.5 and 31.0 m.

Under the piers there are 4x10 piles with dia 1500 mm, with the length of 28.0 meters.

### 4.3. Substructure

#### 4.3.1. Abutments

At the abutments 20.5x4.5 m pile-caps were made with 2.0 m thickness. Over the pile-caps solid structural beams with wing-walls were designed to support the end of the superstructure. Maurer D160 type expansion joints were built in between the retaining walls and the superstructure.

#### 4.3.2. Piers

The 20.5x7.5 m pile-caps are 2.50 meter thick. The cross section of the piers are rectangular, two cell boxes of 11.75x2.75 m, with wall thickness of 30 and 40 cm. This ensures sufficient flexural stiffness even during construction and in final stages, too. The pier heights vary between 13.75 – 17.35 m.

At the top of the piers there are three massive concrete blocks for placing of bearings and location of guides for lateral movements of the superstructure during the launching. Three pot-bearings were placed on the pier-cap under the webs of the superstructure: one is transversally guided and two of them are movable in all direction.

### 4.4. Superstructure

For this extra wide superstructure a two-cell prestressed concrete box girder was applied. The cross section has cantilever slabs on both sides. The neighbouring box girders were made in order to have a simpler technology with the same horizontal radius, 1491 m. The length of the plate-cantilevers was of course different.

The construction of the superstructure was executed by incremental launching. The segment-length, mostly of half span of 20.0 m ensures the most element of the same type. Generally we had to construct two types of segments: the first above the supports and the other type between them. The segments were produced in construction deck behind the abutment.

When the concrete reached its required strength they were connected to the completed part of the bridge with prestressing tendons.

After completing and connecting a segment, the superstructure was moved forward parallel to the axis with the help of lifting-pushing jacks placed on the abutment.

### 4.5. Prestressing of the superstructure

Two types of prestressing system were applied at this bridge. Straight tendons were used for the incremental launching,



**Fig. 6:** S27 viaduct – Prestressing

placed into the bottom and top slabs of the box. Blocks were attached at the end of the segments for anchoring the tendons. Each of the tendons consist of 15 prestressing strands of 0.6" diameter and were anchored into Dywidag MA 6815 type anchoring heads and anchoring body with ribbed outside surface.

There were 2x4 tendons in the cantilever slabs, 2x10 tendons at the top slab and 2x6 tendons at the bottom slab (Fig. 6).

For the service state 3x2 external tendons were applied inside the box girder. These tendons were composed of four pieces of double protected VT-CMM 04-150-D tendons, product of the Vorspann Technik GmbH. The tendons were anchored in VT-CMM 16x150 type anchoring heads.

## 5. CONCLUSIONS

At the M7 motorway beside the Lake Balaton four prestressed concrete bridges were constructed by means of incremental launching. This method provides to build economically long bridges in a required short construction time. This technology is suitable for the bridges with approximately 50 m spans.

The length of the bridges varying between 166 and 304 m, and the width between 14.38-23.58 m. The superstructures of the bridges are with one or two cell hollow-box girder, two with straight and two with curved axis.

The box-girder was reinforced by internal and external prestressing tendons.

The foundations of the bridges consist of bored piles. The pier-walls are reinforce concrete hollow box structures with rectangular cross section.

The constructor of the four bridges above was:

**Hidépítő Co.**

The designer of the S7, S14 and S16 bridges was:

**Pont-TERV Co.**

The designer of the S27 bridge was: **Hidépítő Co.**

## 6. REFERENCES

- DSI-Dywidag System International (1998), "Dywidag bonded Post Tensioning Systems – Multiplane Anchorage (MA)"
- Göhler, B. (2000), "Incrementally launched bridges (Design and Construction)"
- Vorspann Technik GmbH (1993), „Externe Vorspannung” VTM-CMM System
- Wellner, P., Mihalek, T. (2000), „ Viaducts on the Hungarian-Slovenian railway line-3. Design of the viaducts” , *VASBETONÉPÍTÉS 2000/2*, pp. 53-61. (in Hungarian)

**András Lontai** (1954), MSc. structural engineer. He graduated in 1982 from the Technical University of Budapest (BME). Currently he works for Pont-TERV Co. as sectoral chief engineer. He was involved in designing a number of large bridges including bridges over rivers Danube and Tisza. His main field includes structural designing of prestressed concrete bridges built using different technologies, and designing technologies for large steel and prestressed concrete bridges. He is a member of Bridge Engineers Division of the Hungarian Chamber of Engineers, and of the Hungarian Group of *fib*.

**András Nagy** (1973), MSc. civil engineer. He graduated in 1998 from the Technical University of Budapest (BME). His thesis was made at the Technical University of Osaka, Bridge Structures Department. Since 1998, he has been working for Pont-TERV Co., as a leading designer. His main field includes designing reinforced concrete and prestressed concrete bridges. He participated in designing a number of bridges over rivers Danube and Tisza, and in designing the Kőröshegy viaduct.

**Tamás Mihalek** (1950), MSc. Structural Eng. He started his designing profession at Hidépítő Co. He took part even in technological design works beside designing bridges with monolithic superstructures and ones made with precast beams. In 1988 he took part in the design works of Hungary's first bridge built by the incremental launching technology in Berettyóújfalu. Since 1996 the Technical Department of Hidépítő Zrt has been designing the incremental launched bridges (constructed by the company) under his direction. The main fields of his interest are: design of prestressed concrete bridges, the influence of the structural materials and the applied building technology on the structure and considering these influences during statical calculations. He was the leader designer of the viaducts on the Hungarian-Slovenian railway line and of the Kőröshegy viaduct. At present he is the design manager of Hidépítő Co. He is a member of the Hungarian Group of *fib*.

# UNDER DANUBE RIVERCROSSINGS OF PRESSURE PIPES WITH LARGE DIAMETER



László Tóth

The function of civil engineering structures is generally water storage or exclusion considering the strength and stability aspects, which means the fulfilment of functional objectives. Regarding the strength analysis of the structures made of waterproof material the realisation of the crack-width control conditions must be justified. Reinforced concrete pressure pipes with large diameters can be applied only in special cases. The detailed analysis of construction technology, steps of implementation as well as temporary (in construction period) conditions is indispensable at the special structure designing procedure especially in case of the „unique” construction technologies due to large depth.

**Keywords:** pressure pipes, micro tunnelling technology, life cycle, waterproof, deep structure, environment protection

## 1. INTRODUCTION

In Hungary there are many sectors of environment protection calling for significant development. The accession to the European Union, the previous agreements as well as the accommodation to EU guidelines requires the scheduled elimination of the existing short-fail in the field of wastewater collection and treatment. In accordance to that a wastewater treatment plant with the capacity of 350.000 m<sup>3</sup>/d is under construction in Budapest on the Csepel Island. The technical solution of that is considerable regarding different professional aspects especially the covering of large reinforced concrete structures, building-up green roofs. The presentation of the establishment complex can be expected in the project finalisation period in the year of 2009. However, some of the structures built in the framework of preparation process are informative.

The wastewaters collected in the quarters located along the two sides of the river Danube can be discharged via pressure pipes to the wastewater treatment plant to be built on the island. The realisation of the developments linked to the wastewater treatment plant project is proceeding under separated contracts, which have been far-gone close to finalisation. The pumping stations and pressure pipes form a common hydraulic system included the receiving structure of the wastewater treatment plant, so closely related to each other regarding their functions. However, they can be sectioned in the aspect of contracting and topographic reasons and handled separately regarding the professional point of view.

The objective of this paper is to present the technical solution of the twin Kelenföld – Ferencváros deep laying pressure pipes with the dimension of 2xDN1400 under the river Danube. The pressure pipes of large diameters were made of reinforced concrete and constructed with micro tunnelling technology.

## 2. MAIN DATA OF TWIN PRESSURE PIPES

The wastewaters treated at the South-Pest and North-Pest Wastewater Treatment Plants built earlier in the capital make

the 40% of the total wastewater quantity of Budapest. With the inauguration of the new Central Wastewater Treatment Plant more than 90% of the wastewaters will be treated. At the time being the wastewaters derived in Buda side – excluded the northern area – flow untreated to the river Danube in a few locations. The main part of those will be discharged via the Buda Main Collector to the Kelenföld Pumping Station. The wastewaters of the bay are also directed to the Kelenföld Pumping Station from the Albertfalva Pumping Station towards northern direction. From that Pumping Station the total wastewater quantity of 4.4 m<sup>3</sup>/sec shall be led to the Central Wastewater Treatment Plant. About 1/3 proportion of that is dry-weather wastewater and the larger proportion is so called diluted wastewater.

The 6 m<sup>3</sup>/sec wastewater quantity originated in Pest side discharged to the Ferencváros Pumping Station shall be directed to the Central Wastewater Treatment Plant via the river-crossing of Soroksár Danube side-stream. The surplus waters of both pumping stations will be discharged partly to the drift-line of the Danube or in case of great storms to the river via outfalls.

The construction of the pressure pipes of 2xDN1200 and 2xDN1400 have become necessary for the transportation of the

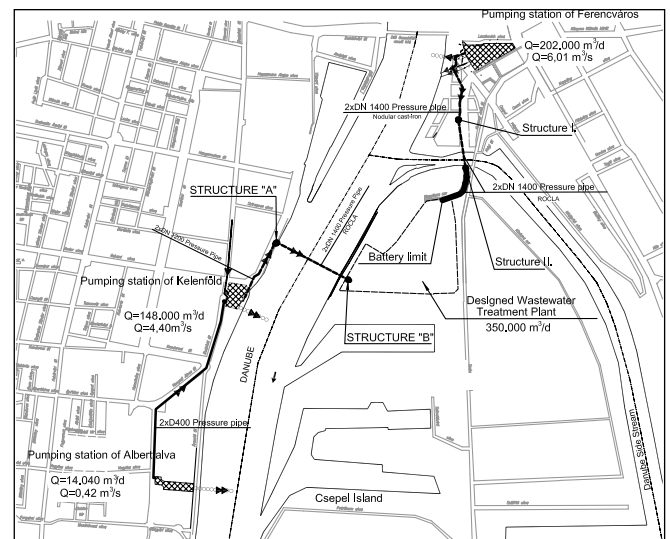

Fig. 1: General Layout

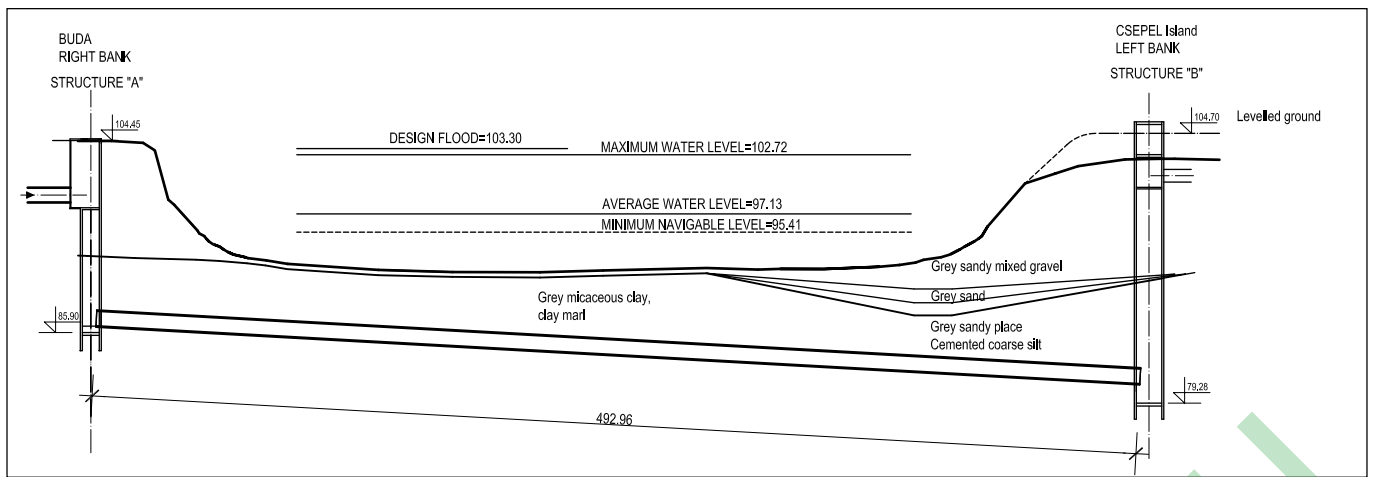

Fig. 2: Under Danube deep laying pressure pipeline

maximum water quantity described above based on hydraulic considerations and the aspects of safe operation. The paths of pressure pipes can be seen in Fig. 1. The alignment survey has been chosen upon a number of clarification meetings and many-sided technical considerations on the basis of the related Spatial Regulation Plan and ownership relations. Regarding this article the details of that is not on the table, but the highlighted analysis of the vertical paths of the twin pipes is of expedience for the Danube and Soroksár-Danube side stream river-crossings.

Due to the 500 m width of the Danube, the close Csepel Duty-free Port and the environment protection requirements related to the life of the river Danube the deep laying pressure pipeline has been accepted as the most reasonable technical solution. That has been backed with the geotechnical condition that the basic rock mentioned as Kiscell clay begins under the real bed of the Danube in the related paths. Referred to the data of bed drillings the location of the twin pressure pipes has been designed with about 5 m covering regarding their vertical paths.

The vertical paths characterized by the depths of 20-25 m have been applicable with well-known construction technologies. The so called micro tunnelling technology was applied in the developed Western-European countries first, but recently there have been realised Hungarian references as well. The most significant one has been created by the Alterra Ltd. with the developments of Szeged Wastewater Sewerage Network and Wastewater Treatment Plant finalised in the last years. With that building technology have been constructed main collectors with large diameters in under ground-water areas. The pressure pipes described above will be constructed also by the contractor Alterra Ltd. The practical experiences gained in the referred project of Szeged assisted the designed solution of the deep laying pressure pipeline under the river Danube. As an important difference the significantly larger depth and the pressure pipe capacity can be mentioned compared to that of the Szeged gravity main collector. The deep under Danube sections of Kelenföld twin pressure pipe are presented in Fig. 2 in vertical section. The description of the pressure pipe sections before and after the deep structures shown in the Figure (A and B) is not the subject of this paper.

The deep laying pressure pipeline section of the Ferencváros twin pressure pipe has the length of about 300 m. In the Figure of Layout can be seen that one of the deep structures (Structure II) is located on the Csepel Island bank of the Soroksár Danube close to the Kvassay gate. The location of the other structure (Structure I) has been chosen on the Pest side of the 100 m wide Danube side-stream in the distance of about 200 m from the

bank on the area owned by Vituki (Scientific Research Institute for Hydraulic Works). The main reason of the latter choice based on the requirement of the related Spatial Regulation Plan, the existing buildings as well as the aspects of environment protection. The deep laying pressure pipeline section of those twin pipes is presented in Fig. 3 in cross section.

In accordance with the above mentioned the construction of some 500 m long deep pressure pipe sections under the Danube and about 300 m long under the Soroksár Danube side stream was necessary. Due to the application of the same tunnel shield it was reasonable to design the under Danube sections with the same DN1400 dimension in spite of the different transported water quantities.

### 3. CONCEPTUAL BASIC ISSUES OF PUMP-SHAFTS ON THE RIVER BANKS

The deep laying pressure pipeline sections described above have been designed with the same configuration regarding the structural as well as construction technology aspects. From the point of view of vertical paths the requirement of monodirectional slope of pressure pipes was of main importance for the cleanability of the deep laying pressure pipeline. The required lengthwise slopes had to be chosen so that the characteristic coverage of 5 m would be available above the pipe top in the Kiscell clay during the construction period. Upon the geotechnical expertises the incidental sand veins were not excluded meaning the risk of inrush of water in micro-tunnelling period. Considering the 4.50 m axis distance of the two pipelines a safe vaulting can be set in. Due to the different length of the pipelines sections as well as the differences of soil layer structures the depths of the pump-shafts differs from each other. That has been backed also by the geodetic differences at the locations of the shafts.

The pump-shafts located at the ends of the pipelines are uniform regarding their foot-prints. In the construction period the structures with the characteristic internal diameter of 12.0 m (B and II) were functioning as starting shaft of micro tunnelling. The drill shields arrived to the shafts with the internal dimension of 8.0 m (A and I), so they can be handled as receiving shafts. The designing of the shafts with the characteristic depth of 19.0-27.0 m is not an ordinary task at the groundwater conditions depending on the actual water level. This statement is relevant for the status in construction period as well as after finalisation. The latter means that the structures being starting

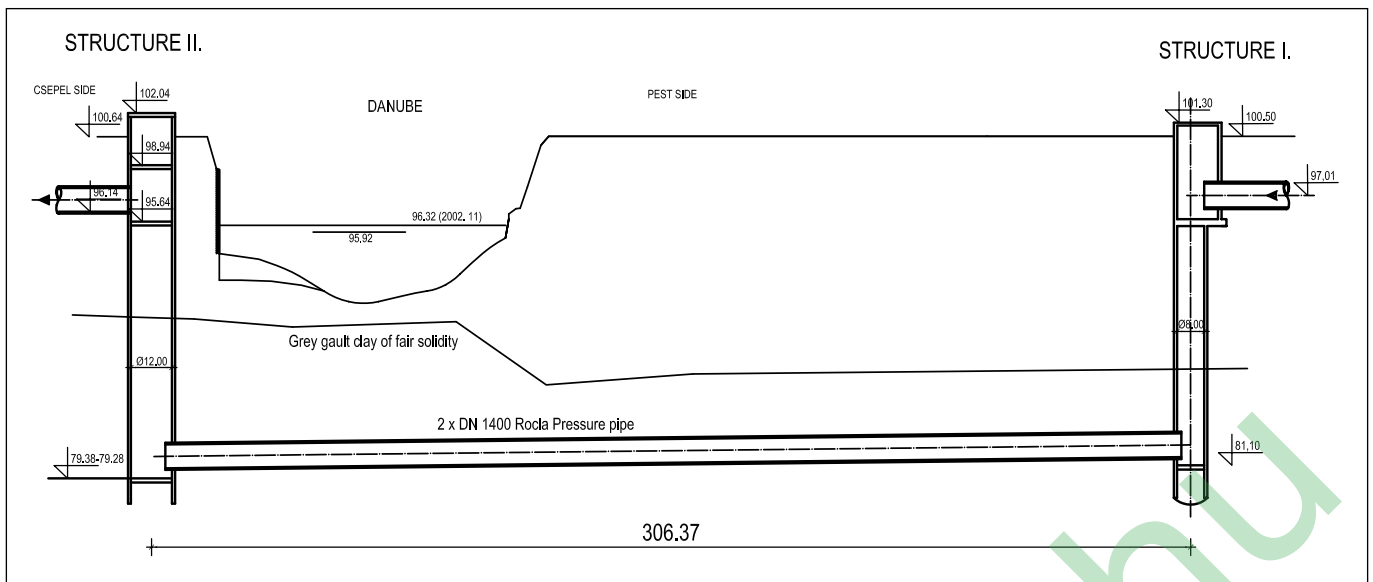

Fig. 3: Under Soroksár Danube deep laying pressure pipeline

and receiving shafts during constructing get final functions, too. The connections of the subsurface and deep pressure pipes, the vertical sections of those shall be formed in the shafts. During the operation of pressure pipes disconnecting and especially periodical cleaning requires professional allocation, handling and change of different lock devices. The fittings of the pipes of large diameter are engine driven, significantly heavy, and their supporting structures have to accept the axial forces derived at directional changes. A crane-truck is needed for the mounting and fitting changes and especially for cleaning of the shaft, which needs access road and surface covering adjacent to the structure. The vertical motion of fittings can be proceeded via the holes of the intermediate floors located overhead each other. That can justify the lightweight construction covering of the end floor. In the shafts there are electric switch devices and biofilter units applied for odorous air control.

The final function of pump-shafts can be understood upon the mechanical engineering and functional issues explained above. The structural solution of the two different structures detailed further has been designed in accordance with those issues, too. Only the shafts A and B will be described because the shafts I and II are of analogous configuration.

### 3.1. Condition of shafts in construction period

The starting and receiving shafts were constructed from a rank of pile consists of drilled piles of large diameter interlocking each other in micro tunnelling period (in Fig. 7 and 10). The piles are supported at the bottom with the foundation slab of the final reinforced concrete structure and at the top with a reinforced concrete annular beam (in Fig. 4). The structure open at the top has been designed by the Taupe Ltd. the subcontractor of BRK Special Civil Engineering Ltd. in the cooperation with our company. The curiosity of the designed solution is the fact that the interlocking drilled piles have two sorts of depth. Every second reinforced pile is led under the lower level of the reinforced concrete foundation slab until the depth of 3.0 m. The interim piles will be led also to the characteristic depth of 3.0 m in the Kiscell clay layer of large thickness. In the line the same piles the surfaces /bands/ between the deep reinforced concrete piles were closed with dry shotcreting in the excavation period. Consequently the

stability of the thick Kiscell clay layer could be utilized during micro tunnelling. The described solution ensured the trench stability as a quasi-pressed cylindrical shell for the pressure of the soil above Kiscell clay layer and ground-water. In the lower sections the Dörken plates placed behind the shotcrete bands discharged the escaping waters to the drainage blanket and sump formed under the foundation slab of the structure. In the constructing period the escapeage could be lifted out from the sump with pump. The water pumping from the sump is always necessary until the complete shaft structure is readymade, so the sump elimination can be carried out only at the final stage of constructing.

The detail of “cogged” configuration of the reinforced concrete foundation slab of the structure is considerable (in Fig. 5), namely the cantilever configuration led to the surrounding soil between the piles, laid straight on end. Applying that solution the clay ring surrounding the drilled piles was involved into load cycles considering the angle of friction. That improved significantly the stability against uplift.

During the micro tunnelling of the pipes with large diameter the equipment needed for compression were set to the temporary base concrete, guiding rails, drill shield, backing, etc. In the case of starting shaft a temporary reinforced concrete backing forwarded the compressing forces needed for the approx. 300-500 m long compression to the side wall structure described above. Considering the interim compressing stations the backing had to be designed for the compressing force of maximum 500 t within the starting shaft. After the finalisation of compression the temporary structures were demolished.

### 3.2. Final structural configuration of shafts

The functional demands presented in the previous chapter are calling for the configuration of the monolithic reinforced concrete shaft made of waterproof material. Consequently the stages of construction were followed by the construction of monolithic reinforced concrete lining wall with slip-form construction method, cylindrical surface inside, with the characteristic thickness of 45 cm (in Fig. 6 and 7). The external surface of the lining wall was adjusted geometrically to the inner surfaces of the trench supporting structures. Regarding its layout configuration a reinforced concrete division wall is

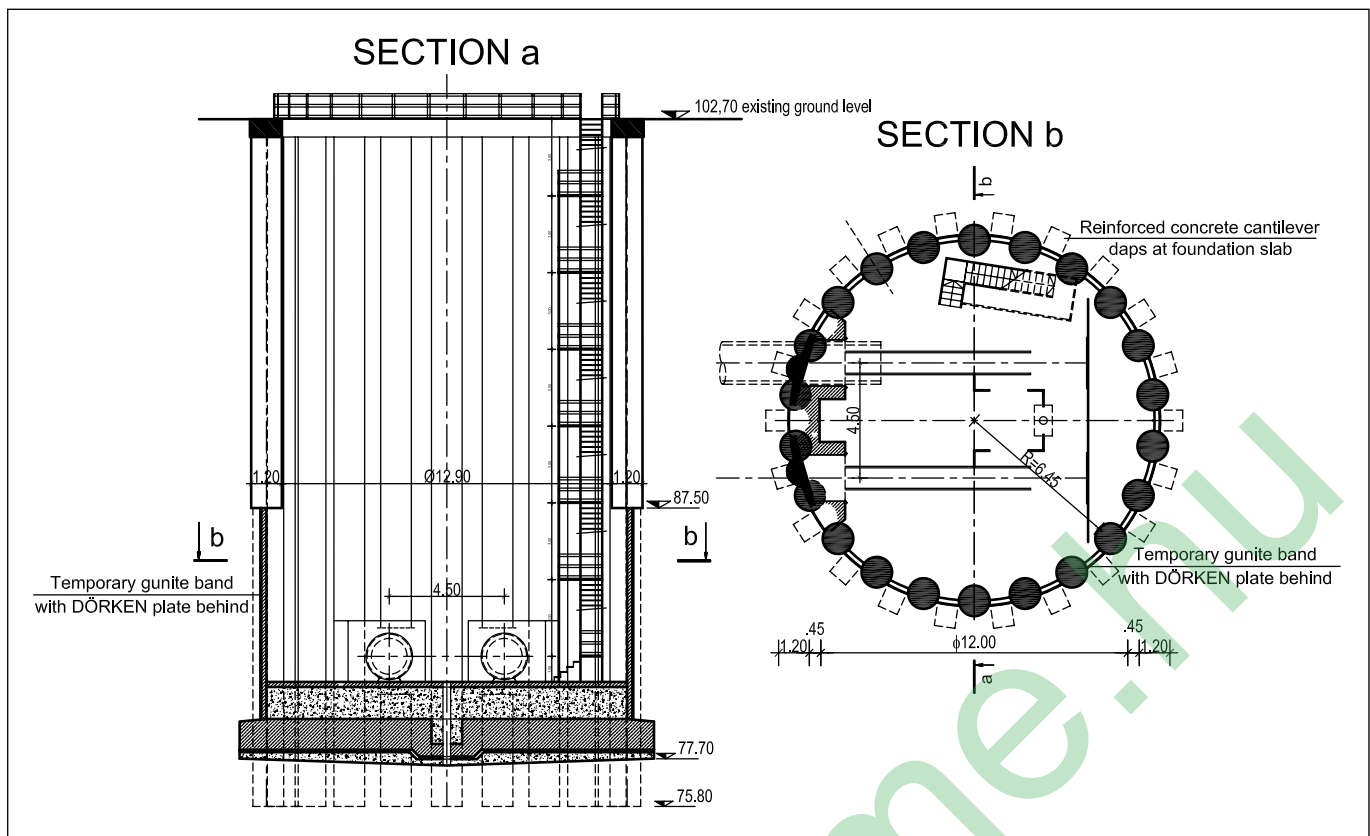

**Fig. 4:** Vertical section (a) of the structure "B" (status of compression)

**Fig. 5:** Horizontal section (b) of the structure "B" (status of compression)

to be built along the diameter of the circular structure with breakthroughs meeting the operational requirements. That reinforced concrete division wall supports obviously the foundation slab, the cylindrical side wall along two lines and last but not least the horizontal floors. Regarding its structure the spatial box-structure with circular foot-print is a final stage banded with the entering and out-coming pressure pipes, which has been calculated for soil and groundwater pressure. The joints meet the waterproof requirement and force forwarding demands at both the entering and out-coming points.

There is a significant difference regarding the structures (A and I) serving as receiving shafts in the compressing period. In the compression period the temporary function ceases after taking out the drill shield from the open trench bordered with the interlocking piles. The final configuration has been adjusted to the mechanical engineering requirements consequently the shaft built earlier with circular symmetry bells out asymmetrically at its upper part (Fig. 8-10). The foot-print of the mechanical appliances and holes set up in the horizontal branches of the pressure pipes claimed the floor-plan dimensions of the 5.0 m deep shaft. The rigid monolithic reinforced concrete box-structure made of waterproof material is supported with piles. In that case a designed bracing is also needed for the stages of constructing due to first of all the modification of the former circular symmetric loading.

## 4. CONFIGURATION OF PRESSURE PIPES

After giving a short description on the horizontal and vertical paths of the pipes with large diameter their materials and load cycles are reasonable to analyse. Taking into consideration building technologic and structural aspects the designers decided to apply the pipes made of reinforced concrete. In accordance with the experiences of practice the well-known

bell and bolt joint of the reinforced concrete compressed pipes prefabricated in factory conditions meets the demands. Regarding some highlighted aspects the choice of material can be justified in accordance with the following.

### 4.1. Hydraulics, pressure conditions

Upon the analysis of the complex hydraulic system involved the pumping station, the pressure pipe of total length and the receiving structure of the wastewater treatment plant it came to the light that the maximum pressure due to water transportation in the deep sections of the twin pipes varies between 3.5 - 4.0 bar. Regarding the dimensioning of pipe cross section for the actual operational pressure the external water pressure affecting to barrel-casing also could be taken into consideration. The design forces derive from different loaded-up conditions. Summarizing the above it can be stated that the pipes with large diameters produced in Hungary, which have been developed basically for gravity sewers, are adaptable even for pressure pipe realisation with special dimensioning and reinforcement.

### 4.2. Life cycle requirement

Twin pressure pipes can be qualified as communal basic establishments considering the importance and cost demands of the total establishment complex included the wastewater treatment plant. Consequently the minimum life cycle requirement of 50 years was of significant importance regarding the choice of material. From that point of view the application of reinforced concrete pipes of good quality produced in factory conditions is satisfying because significant damage caused by corrosion is not expected. However at the internal surface of pipes the abrasive effect of the solid content

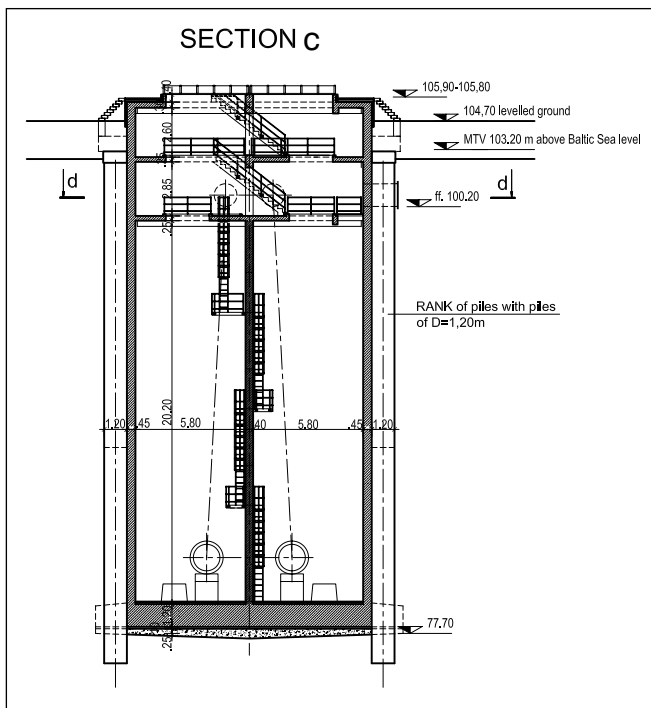

Fig. 6: Vertical section (c) of the structure "B" (final status)

of wastewater (first of all sand) shall be taken into consideration in spite of the fact that in accordance with experiences a greasy film like coating layer used to be formed on the internal surface of wastewater pressure pipes. Corresponding to that consideration, the designers enlarged the concrete cover and with that the wall thickness with 2 cm on the internal surface of reinforced concrete pipes. The production technology has been adequate for that. For the purpose of life cycle improving the designers prescribed epoxy covering layers to the internal surface of pipes produced in the factory. In factory situation the conditions of good adherence could be assured regarding the epoxy covering of two components. That internal surface is of advantage even from hydraulic aspect because the coefficient of friction decreases essentially during application.

### 4.3. Building technology aspects

Additionally to the professional arguments detailed in the previous two chapters the choice of reinforced concrete material was of advantage for the application of micro tunnelling technology. The wood adapters inserted between the rigid pipes are applicable for the forwarding of compression force without any damage of the butting end of pipes. The gaps shaped at the end of micro tunnelling were closed with rubber profile seal. The carbon steel bodies fitting to the external surface of reinforced concrete pipes with the well experienced rubber joints meet waterproof requirement even in the case of special rotating at the pipe adaptations.

### 4.4. Connection of reinforced concrete pipes and structures

In accordance with the detailed description above the reinforced concrete pressure pipe parts crossing the side walls of deep structures have fixed ends at the reinforced concrete side wall due to the subsequent construction of the lining wall. As far as static considerations are concerned the pipes clamped to wall are constructed with steel casing through their ends due to the forces derived at joints. The incidental movements and

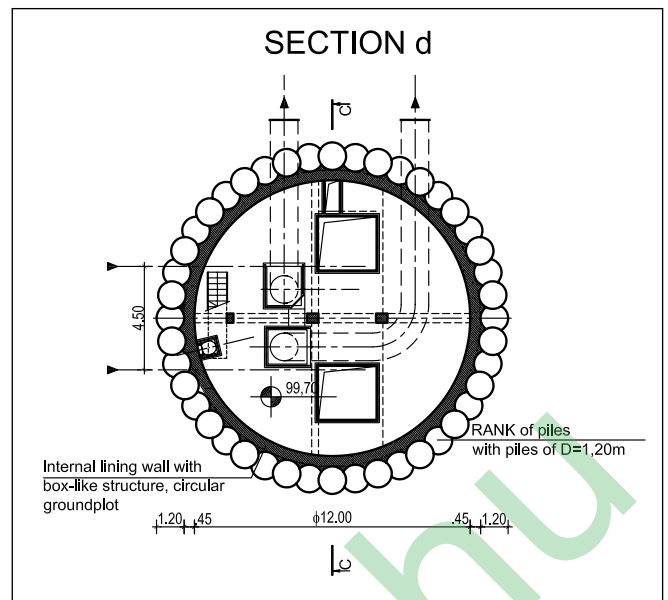

Fig. 7: Horizontal section (d) of the structure "B" (final status)

rotations are developed only at the spigot and socket joints with rubber ring located out of structure wall. In order to improve water-proof attribute expansive joint filler bands were placed before lining wall concreting.

## 5. CLEANABILITY OF DEEP LAYING PRESSURE PIPELINES

In the pressure pipes serving wastewater transportation the sedimentation of solid material shall be taken into consideration even in case of alternating operation of pressure pipes at lower water quantities. In accordance with experiences there is no considerable sedimentation in the wastewater flowing with at least 0.5 m/s velocity. In dry weather periods especially in case of night minimum wastewater quantity only one of the pipes shall be operated due to the above. The maximum water quantity appears only in the significantly rainy periods. In those cases the velocity can reach the value of 2.0 m/s, which delivers as well as the solid materials settled in steel pipe.

Additionally to the general principles described above the technical solution makes possible the cleaning of pipe sections

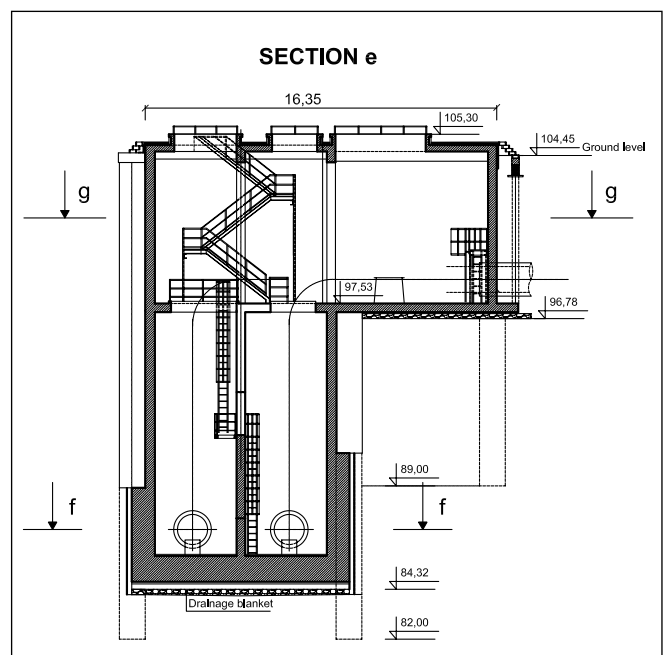

Fig. 8: Vertical section (e) of the structure "A" (final status)



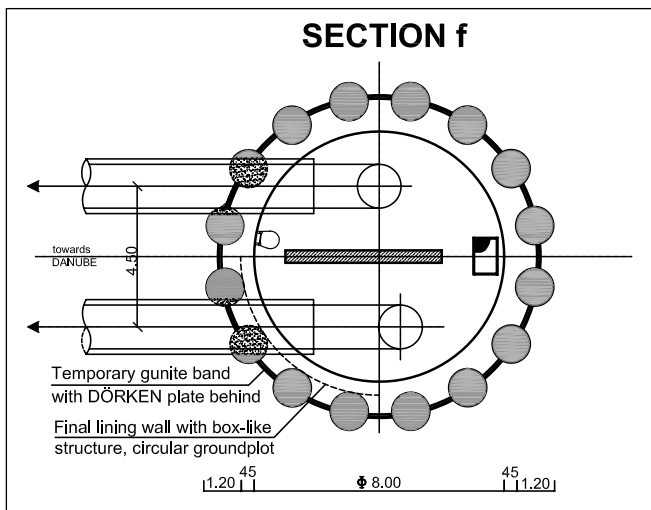

Fig. 9: Horizontal section (f) of the structure "A" (final status)

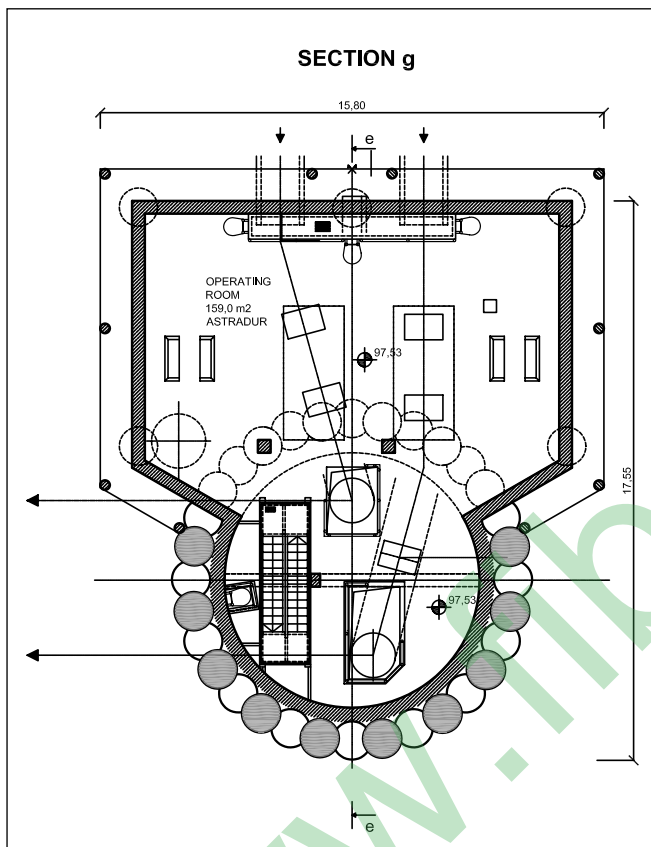

Fig. 10: Horizontal section (g) of the structure "A" (final status)

with the following technology: in a continuous dry period in the pipe out of operation such conditions can be generated with the assistance of fittings, pumps and a porous cleaning head set up in the shaft, that the cleaning head can be pressed with wastewater from one of the bank shaft to the other. In the cleaning period such water velocity develops that absolutely decomposes the sedimentation settled in the pipe bottom and

presses with rolling to the silt-control reservoir built into the bank shaft for that purpose. The essence of cleaning is the fact that the closed system shall be broken only in case of cleaning-head in and out placement and the loosened sedimentation can be discharged via the actually operating pressure pipe to the wastewater treatment plant. That solution is of outstanding advantage from the point of view of environment protection. In those periods the air treatment equipment with biofilter located in the upper part of shafts is also in operation.

## 6. CONCLUSIONS

The designing and construction of the pressure pipes with large diameter applicable for the transportation of significant water quantity is not an ordinary task especially in the cases presented in this paper. The Danube crossing can be regarded a special engineering structure complex consisting of two reinforced concrete bank shafts with large depth and long reinforced concrete pressure pipe sections. The designing and construction of any structural units of the establishment as a complex and difficult task requires special professional know-how. Regarding those rarely occurring deep structures special care shall be taken upon the load accepting derived in construction period as well as in final state. The implementation of those kinds of structures is possible with the application of special building technologies. In the presented case it can be stated that some new solutions needed to elaborate and apply additionally to construction experiences. The presented structure with its special structural configuration and building technology can be qualified as an important civil engineering establishment implemented in Hungary for the first time.

## 7. ACKNOWLEDGEMENT

The structural and construction technologic concept has been elaborated by the experts having great practice in structural designing and civil engineering with the control of the author of this paper and accomplished the final designing tasks sometimes approaching development engineering. During the realisation the experts of Alterra Ltd. contributed to the elaboration of the details of applied building technologic solutions in a very constructive way and assisted the work of designers with their experiences. The author would like to express his thanks to the designer and constructor experts herewith for the constructive cooperation.

**Dr. László Tóth** holds M.Sc. and Dr. Univ. degrees in civil engineering. He took his thesis in 1967 and began to work for Mélyépterv Enterprise as a structural designer. Designed a great number of potable water basin, clarification basins, reinforced concrete water tower, wastewater treatment structures, digester, special structure and building technology method. Developer of the prefabricated pasted reinforced concrete panel system used in the scope of civil engineering. Multi-inventor, publishing regularly, general director of Mélyépterv Komplex CC., member of the Hungarian Group of *fib*.

# DETERIORATION OF STEEL FIBRE REINFORCED CONCRETE BY FREEZE-THAW AND DE-ICING SALTS



Attila Erdélyi



Erika Csányi



Katalin Kopecskó



Adorján Borosnyói



Olivér Fenyvesi

Freeze-thaw testing methods with different grade of severity have been applied to investigate the durability of – intentionally non air entrained – fibre reinforced concretes (FRC) mixed with nominally zero, 25, 50 and 75 kg/m<sup>3</sup> cold drawn steel fibres (30/0.5 mm). Concrete specimens were made with sulphate resistant Portland cement and were stored 28 days in water and under laboratory conditions afterwards. The mineralogical changes of hardened cement paste, the chloride absorption, the changes of the specific electrical resistance and the watertightness were studied to complete the usual mechanical properties tests (strength, Young's modulus, etc.). It can be concluded that an increasing dosage of steel fibres diminishes the loss of mass (e.g. scaling off) of FRC, but fibres themselves can not hinder the severe damage of the exposed surfaces and can not provide freeze-thaw and de-icing agent resistant concrete if it is not air entrained. Salt solution saturation (wet) condition and/or steel fibres impair the specific electrical resistance.

**Keywords:** steel fibre reinforced concrete, durability, frost- and de-icing salt resistance, specific electrical resistance

## 1. INTRODUCTION

It is an overall, simplified view among civil engineers that de-icing with NaCl impairs only the steel reinforcement of reinforced concrete or even more of prestressed concrete members, because of the volumetric increase of around six times when „rust” i.e. iron-oxides and iron-hydroxides are formed from steel during corrosion. This expansion makes the concrete cover to spall, so the corrosion of reinforced and prestressed concrete can get ahead. It is also known (less broadly) that the surface of embedded steel is kept in a passive condition while  $\text{pH} > 9$  and even in presence of chlorides up to a maximum  $\text{Cl}^-/(\text{OH})^-$  ratio of 0.6.

### 1.1. Laboratory testing of the deterioration

Resistance to freeze-thaw cycles and de-icing agents are tested usually on not reinforced concrete specimens, thus

**Fig. 1:** Penetration of chloride into the concrete of a maritime concrete structure in the Netherlands (Polder, Rooij, 2005)

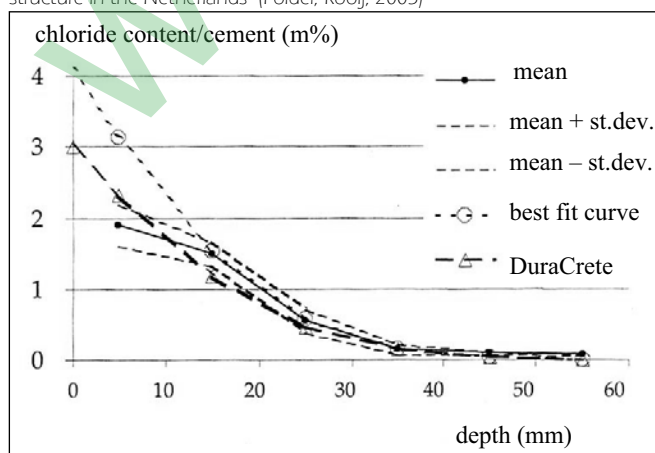

pressure due to forming of rust is excluded and deterioration is simply explained with the expansion of water of abt. 9 V% when crystallised i.e. frozen. Sometimes the *freezing through in layers* of a concrete pavement with different NaCl and moisture content in the different layers is argued with. A similar type of damage is modelled by the *scaling off* test according to the prEN 12390-9:2002, when slab specimens are continuously covered with a NaCl solution of 3 m% on one exposed surface.

According to (MSZ) EN 206-1:2000, reinforced concrete pavement slabs (often saturated with water-salt solution to critical saturation, Fagerlund, 1997) must be characterised with exposure classes XD3 and XD4, i.e.  $w/c \leq 0.45$ , strength class  $\geq C35/45$ , cement content  $c \geq 340 \text{ kg/m}^3$  and entrained air void content  $\geq 4 \text{ V}\%$ .

Damage is also explained by the transport phenomenon of undercooled water in pressure in the capillary pores (Powers idea). Porous materials are damaged due to the pressure of crystallized NaCl in the case of repeated drying and saturation, which was also demonstrated to be a reason of deterioration even without any frost action (see later COMPASS tests of the Netherlands). The capillary suction is the major mechanism of some methods. e.g. the CDF test (Capillary suction of Deicing solution and Freeze-thaw test) (Setzer, Fagerlund, Janssen, 1996). This method and the mentioned scaling off (slab) test are the most severe ones because continuous capillary supply is possible on the contrary to those methods where the specimens lay in the very same non-moving solution during the whole test procedure. As for us, the CDF method with suction of NaCl solution upwards and scaling off downwards can be considered to be the most severe process.

### 1.2. Literature review

In the EU research project called COMPASS led by the Delft Institute of Technology, the Netherlands, 2006 (COMpatibility

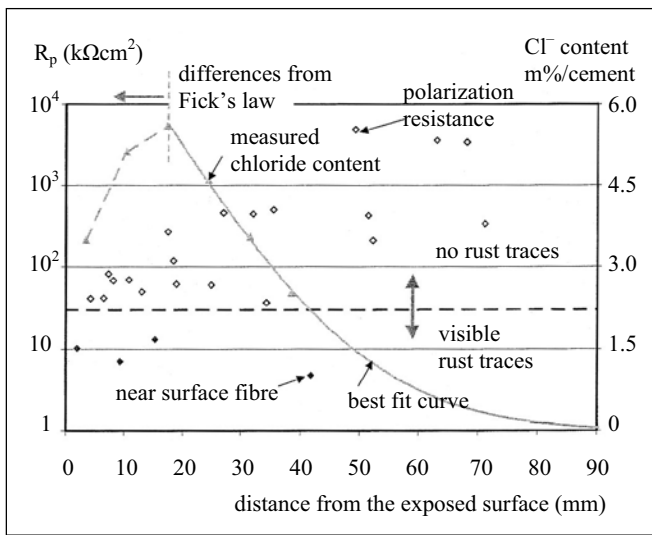

**Fig. 2:** Polarization resistance  $R_p$ , chloride content ( $\text{Cl}^-/\text{cement}$ , m%), distance from the exposed surface and visible rust traces on fibre surfaces (Dauberschmidt, Burns, 2004)

of Plasters And renders with Salt loaded Substrates in historic buildings) high-tech in-situ measurements (e.g. magnetic resonance method) were used to check the deterioration process of stone-like porous materials due to NaCl solution *without frost*, but with the possibility of repeated drying and saturation.

Main conclusions of the COMPASS research are as follows:

- Crystallization of NaCl is escorted with irreversible expansion. The solid salt shrinks when solved and oppositely expands when dried and crystallized. This irreversible expansion is manifested already after some cycles in damage, except when an inhibitor is added to the salt. In this latter case the NaCl crystals can not adhere to the internal wall of the pores and can not force the pores to elongate together with the crystals – so the pore surfaces are not loaded. Without inhibitors they measured (even after two cycles of saturation and drying) a  $0.5 \times 10^{-3}$  residual expansion in a cement-lime mortar (Lubelli, Hees, Huinink, 2006). As for us: in concrete a much smaller initial expansion is expected for two cycles, but the cumulative result of 56 cycles (or up to 300 cycles; USA, Japan) might be astonishing.
- Salt (NaCl) crystallizes before all in the region where the pore structure is changing, e.g. in the transition zone from fine structures into a coarse one. Deterioration can also happen when salt crystals do not completely fill the pores of diameter  $\geq 10 \mu\text{m}$ . Pore structure transition zones are the

result of multi layer rendering of mortar. As for us: a higher water and slurry content of the external concrete layer, i.e. cover is also a transition zone. Salt transport may be hindered by water repellent coatings (Rooij, Groot, 2006).

- The effect of salt solution is more emphasized if combined with wetting and drying rather than stored continuously in a salt solution bath. They also accomplished an accelerated crystallization test to check the so-called salt-resistant mortar rendering (Wijffels, Lubelli, 2006).

In an other research project (Polder, Rooij, 2005) it was demonstrated that the specific electrical resistance (SER,  $\Omega\text{m}$ ) is strongly dependent on the moisture content (SER drops with increasing moisture content). Specimens with ordinary Portland cement (stored under water for years) have a SER as low as 100 to 200  $\Omega\text{m}$ , while specimens with blast furnace slag cement have 400 to 1000  $\Omega\text{m}$ , demonstrating the advantage of blended cement in this respect too.

Chinese experts (Cao, Chung, 2002) working in USA have cleared up that freeze-thaw cycles increase irreversibly the SER due to the microcracks.

Experts in the Netherlands have demonstrated (Fig. 1, Polder, Rooij, 2005) that  $\text{Cl}^-$  content in the penetration profile will get less than the so-called critical 0.4 m%  $\text{Cl}^-/\text{cement}$  only in a depth of 25 to 30 mm; an important argument for thicker concrete cover. SER is increasing together with the rate and measure of drying and the diffusion velocity of  $\text{Cl}^-$  ions is decreasing.

Summarizing the above data it seems that repeated drying periods offers the possibility of an inevitable damage due to crystallization but – on the other hand – it breaks the  $\text{Cl}^-$  ion diffusion by increasing the SER.

The Austrian Guideline for FRC (*Faserbeton Richtlinie, 2002*) declares word by word: „only the fibres extruded from the concrete matrix may rust falling out from the passive environment of concrete (efficiency region). With usual fibres (cold drawn, milled, etc.) this will not cause either spalling or a contact corrosion” (ÖVBB, 2002). Rust on fibre surface does not impair either the load bearing capacity or the serviceability of FRC – though the aesthetics as for architectural *fair-faced* exposed concrete may be unacceptable, except if zinc coated fibres have been used.

The Aachen Technical University (IBAC) published reports especially about the eventual possibility of corrosion of embedded steel fibres in FRC containing different types of fibres (Dauberschmidt, Burns, 2004). The FRC beam specimens were treated one-sided with NaCl solution for 2 years and then tested for the rest electrode potential, polarization resistance,

**Fig. 3:** Distribution of hooked-end Dramix® fibres in our FRC specimens (X-ray images)

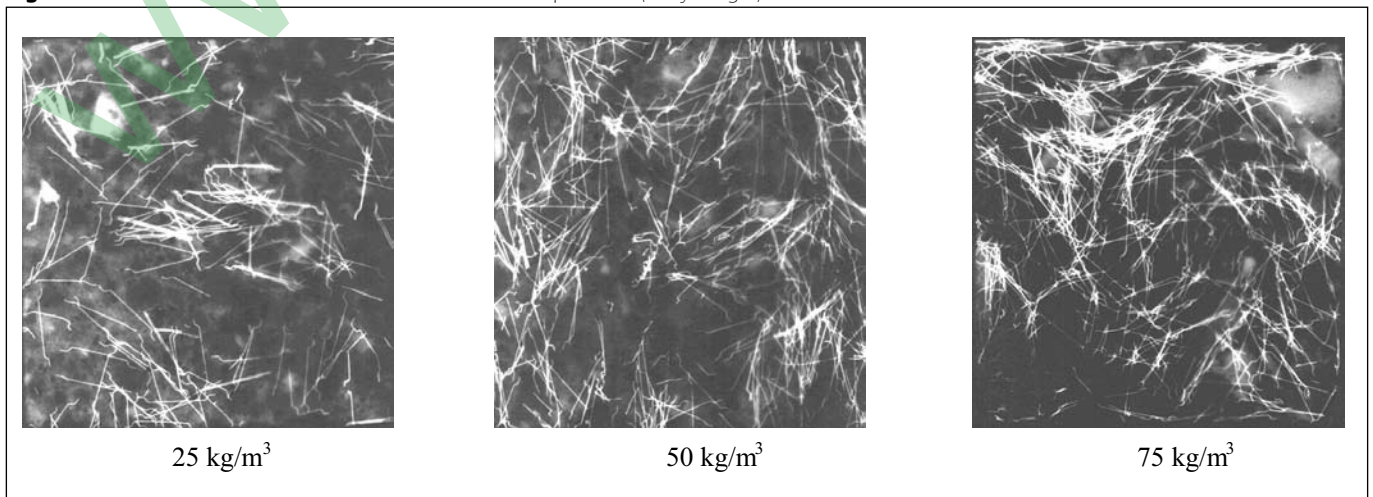

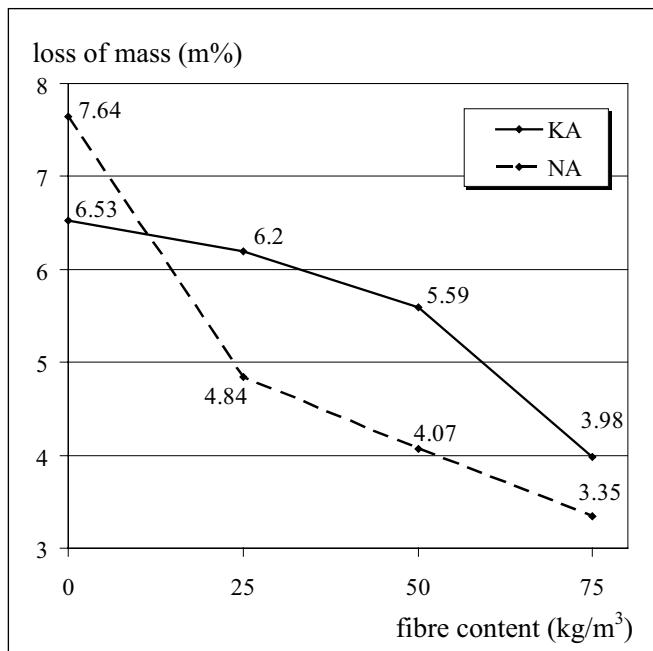

**Fig. 4:** Loss of mass after 32 cycles of half immersed, rotated specimens (method A) depending on fibre content both for series NA, w/c= 0.42 and series KA, w/c= 0.54. (Erdélyi, Borosnyói, 2005b)

electrochemical impedance and current density curves. Cl<sup>-</sup> ion content was also assessed in different depths measured from the surface and finally rust traces were detected on fibres by SEM (scanning electron microscope). The correlation between the above mentioned parameters (all measured by high-tech devices) i.e. R<sub>p</sub> polarization resistance (kΩcm<sup>2</sup>), rust traces, Cl<sup>-</sup>/cement (m%) and depth (mm) within the concrete are shown in Fig. 2. (Dauberschmidt, Burns, 2004). The levels of Cl<sup>-</sup> content that can cause a visible rust on fibre surfaces were different for different types of fibres: for undulated fibres 2.1 to 4.7 m%, for hooked-end fibres 3.1 to 3.9 m% and for smooth ones 3.4 to 4.7 m%. These values are remarkably higher than the often mentioned critical 0.4 m% (which was also criticized years ago by Austrian experts when referring to the corrosion liability of normal reinforcement).

Summarizing the Aachen results, the critical Cl<sup>-</sup>/cement value (m%) was found to be: a) for near surface fibres (pH<12) mean value of 3.6 m%, b) for deeper laying fibres (pH>12) mean value of 5.2 m%.

As it is known, the increasing amount of cold drawing work (expressed as reduction of cross sectional area) improves the corrosion resistance of steel fibres, together with the tensile strength. This parallelism is the background of the advantage offered by higher strength cold drawn wire fibres and not directly their strength. Cold drawing results in tensile stresses to be formed in the core of the wire and compressive stresses in outer layers thus the surface of the wire has higher density. Such thorough research like the Aachen tests has not been found on this specific field in the technical literature up to the year 2007.

Swedish research institutes studied the corrosion resistance of FRC and of reinforced FRC exposed to maritime environment for a couple of years (Bekaert, 1988). Their conclusions:

- Even after 12 years on the exposed (architectural *fair-faced*) concrete surface no traces of rust were perceived if zinc coated EX fibres were applied, while usual cold drawn wire fibres corroded, leaving reddish traces on the concrete surface. Our own tests also demonstrated that even Dramix<sup>®</sup> wire fibres – though they were glued into water soluble small panels and so facilitating the dispersion of single fibres –

**Table 1:** Cube strength of specimens, N/mm<sup>2</sup> (acc. to EN 206-1:2000; 28d)

Type	ref.	Dramix <sup>®</sup> fibre kg/m <sup>3</sup>			ref.	D&D <sup>®</sup> fibre kg/m <sup>3</sup>		
		25	50	75		25	50	75
KA	49	51	49	54	40	47	45	47
NA	51	56	54	54	53	56	55	57

KA: w/c=0.54, c= 300 kg/m<sup>3</sup>; NA: w/c=0.42, c = 400 kg/m<sup>3</sup>

**Table 2:** Tensile splitting strength of 1 year old specimens, N/mm<sup>2</sup>

Type	ref.	Dramix <sup>®</sup> fibre kg/m <sup>3</sup>			ref.	D&D <sup>®</sup> fibre kg/m <sup>3</sup>		
		25	50	75		25	50	75
KA	3.3	3.2	3.9	4.3	3.2	2.7	4.3	4.9
NA	3.1	3.0	4.1	4.8	4.1	3.2	3.9	5.2

KA: w/c=0.54, c= 300 kg/m<sup>3</sup>; NA: w/c=0.42, c = 400 kg/m<sup>3</sup>

may adhere and so with higher fibre content or lower paste content poor workability and inadequate embedding may occur (see our X-ray images in Fig. 3.).

- Steel fibres do not corrode if we have cracks less than 0.25 mm width. The background of the phenomenon is that during compaction of the concrete an interfacial layer of about 50 μm thickness is formed around the fibres that is very rich in Ca(OH)<sub>2</sub> providing a passive environment against corrosion.
- The rust on cold drawn wire fibres is not expected to cause spalling cracking due rust expansion pressure, because of the slight total volumetric increase on fibre surfaces.

## 2. PRESENT STUDIES

In present experimental research we tested and evaluated the durability of SFRC specimens, which – intentionally – were cast with sulphate resistant Portland cement and without air-entraining agent. The beneficial effect on durability of the entrained air-void system was therefore excluded, as well as excellent sulphate resistance was achieved (this latter is not reported in present paper). Steel fibres only (zero and nominally 25, 50, 75 kg/m<sup>3</sup> i.e. zero, 0.3, 0.6, 1.0 V% in present test) could have influences on durability which we restricted here to the overall resistance against freeze-thaw and de-icing agents.

The following test methods have been applied and developed, respectively:

*Method A:* 75×75×150 mm prisms sawn from older bigger (75×150×700 mm) beams were immersed up to the half of their thickness (75 mm) into 3 m% NaCl solution, and rotated by 90° after each 8 cycles. We ran 4×8=32 cycles because the spalling seemed to be high enough to reach 5 m%. This method is *more severe* than usual methods that are using totally immersed specimens. Here, all the four sides of specimens were exposed to capillary suction, became saturated, dried out and enabled to an eventual crystallization of NaCl. Results (Fig. 4.) support our supposition.

*Method B:* the same as above, but *without rotating* the prismatic specimens. The *method B* seems to be less severe than *method A*.

Both *methods A* and *B* (developed in our Institute) are faster than the conventional testing methods and the access of oxygen, carbon-dioxide, capillary salt absorption during cycles may accelerate the damage of concrete matrix and a possible corrosion of steel fibres, too.

Our most important test was the conventional *slab test* (prEN 12390-9:2002) carried out with heat insulated 150×150×50 mm slabs (sawn from bigger specimens). Exposed surfaces

were prepared just before the test began. As prescribed: 7, 14, 28, 42 and 56 cycles were applied, the 3% NaCl solution was changed to a new one in each step and *scaling off* was measured. Here we emphasize that the prEN 12390-9:2002 should be amended with a new regulation namely that NaCl solution must be *chemically analysed* to study what and how much substance has been diluted step by step from the originally intact matrix.

Beside losses of mass also the change of ultrasound pulse velocity (UPV) was measured to characterize the deterioration. The mechanical decomposition was described by the drop of the initial Young's modulus ( $E_0$ ) comparing the values in non-frost-attacked (NF) condition and after freeze-thaw cycles (F). Stress-strain diagrams, the changes in compressive strength (prism 1:2) and splitting tensile strength have been evaluated. The electrochemical accessibility (transmittance), i.e. the readiness for  $Cl^-$  and other ions to diffuse through FRC was described by measuring the SER ( $\Omega m$ ) of specimens without and with different dosages of steel fibres in several conditions.

Photographs were taken from the split specimens after the tensile tests to detect and record the surface condition of well and less embedded fibres and of those extruding to the worn surface after scaling off.

The heavy (unexpectedly high) losses turned our attention to a thorough chemical analysis with X-ray diffractometry (XRD) and differential thermo-analysis (TG/DG/DTA), together with  $Cl^-$ /cement (m%) content.  $Cl^-$  ion profiles were not recorded, because the literature review provided us more than enough information (see Fig. 1. and 2.) about these curves measured on realistically thick FRC specimens. Our own specimens with their thickness of 75 mm were anyhow not suitable to record  $Cl^-$  penetration curves.

A necessary but not sufficient precondition of durability is watertightness and small water penetration, which was also tested applying 5 and 6 bar water pressure for 72 hours (or longer), either stepwise (according to MSZ 4715/3 Hungarian Standard) or in one step (according to EN 12390-8:2000 European Standard). Watertightness tests were carried out both on specimens in non-frost-attacked (NF) condition and on specimens after freeze-thaw cycles (F).

### 3. STUDIES ON SCALING OFF

#### 3.1. Results on strength

During a previous research project (supported by the Hungarian Research Fund, OTKA, reg. No. T 016683) our main focus was on the toughness behaviour of FRC specimens of the same composition as used in present experimental studies, too.

The available former strength results (mean values) are

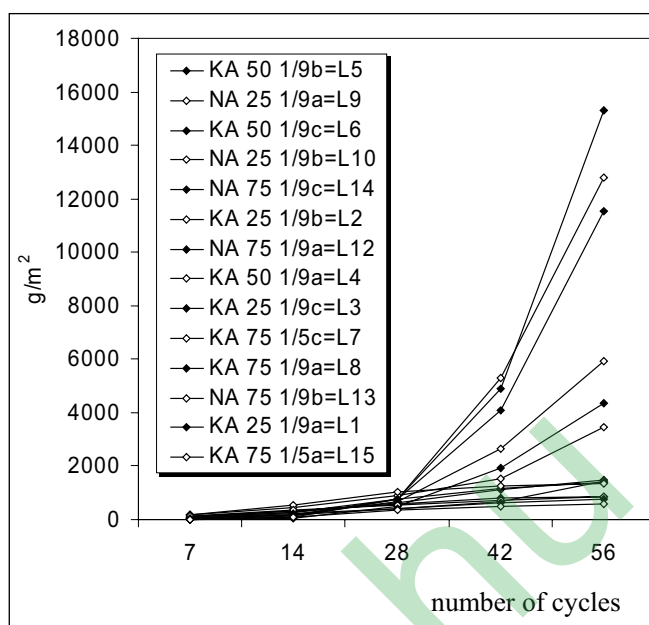

Fig. 5: Cumulative normalized scaling-off losses of slab specimens ( $g/m^2$ ) vs. number of cycles (prEN 12390-9:2002).

summarized in Table 1 and 2, where (and later on in present paper) the key for symbols is:

KA:  $w/c = 0.54$ ;  $c = 300 \text{ kg/m}^3$ ; CEM I 42.5;  $f_{cm} = 55$  to  $62 \text{ N/mm}^2$ ,

NA:  $w/c = 0.42$ ;  $c = 400 \text{ kg/m}^3$ ; CEM I 42.5;  $f_{cm} = 60$  to  $70 \text{ N/mm}^2$ ,

The all-over mean value of cube strength results with I. Dramix® (hooked-end, 30/0.5 mm) fibres  $62.3 \text{ N/mm}^2$  and with II. D&D® (undulated, 30/0.5 mm) fibres  $64.7 \text{ N/mm}^2$ . Values (Table 1) are almost the same and that is in accordance with the technical literature.

The splitting tensile strengths were measured on sawn halves of 1:2 cylinders ( $\varnothing 150 \times 300 \text{ mm}$ ) at age of 1 year. Values are indicated in Table 2. The toughness increment is demonstrated. In our tests the splitting tensile strengths were over 4 to 5  $\text{N/mm}^2$ . The increase is considerable, comparing with the 3  $\text{N/mm}^2$  splitting tensile strength of the control specimens, however, it is not multiplied as sometimes announced in marketing leaflets.

Strength results can be concluded as:

- 28 days cube compressive strength (water saturated condition) depends only slightly on the fibre content or type of fibres.
- 1 year old 1:1 cylinder compressive strengths (air dry condition) are also rather similar to each other, slightly increasing with increasing fibre content.
- It is possible to make a proper FRC already with a relatively small cement content of  $300 \text{ kg/m}^3$  (KA);  $f_{cm} = 55$  to  $62 \text{ N/mm}^2$ .

Fig. 6: Normalized scaling off values of arranged sample in increasing order after 56 cycles ( $g/m^2$ )

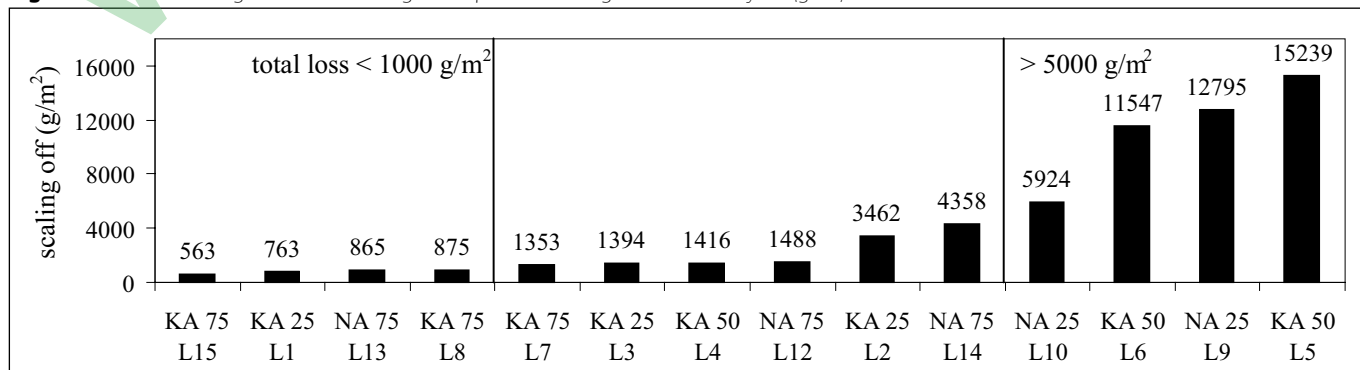

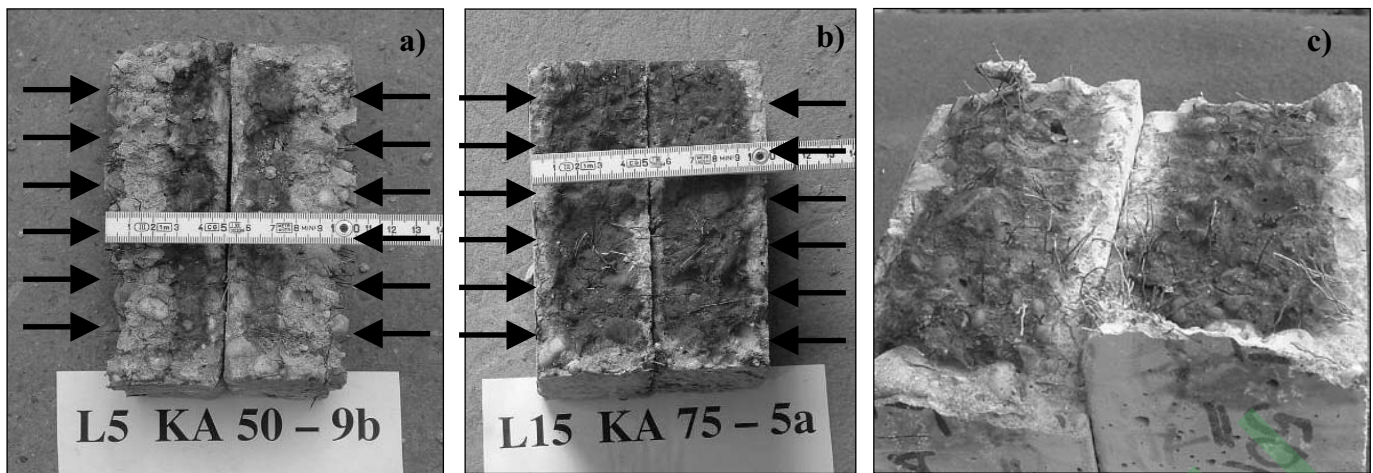

**Fig. 7:** Freeze-thaw exposed specimens after splitting tests indicating phenolphthalein negative outer regions (in pale tone) and phenolphthalein positive inner regions (in dark tone).

- a) The most damaged specimen after 56 cycles (scaling off 15239 g/m<sup>2</sup>)
- b) The least damaged specimen after 56 cycles (scaling off 563 g/m<sup>2</sup>) (arrows indicate the exposed surfaces)
- c) 10 years old specimen split after watertightness test (sound, dull grey steel fibres are visible with no rust stains)

- Steel fibres considerably improve the splitting tensile strength (more than 50% increase).

### 3.2. Results of present scaling off tests (prEN 12390-9:2002)

All the specimens (numbered from L1 to L15) were tested up to 56 (prescribed) cycles. High scaling off (g/m<sup>2</sup>) was measured. After 28 days = 28 cycles the scaling off was more than 1000 g/m<sup>2</sup> for most specimens. The best specimens could fulfil the Swedish requirement (<1000 g/m<sup>2</sup> 56d) but their loss expressed as m% was the double of that of immersed specimens (either rotated or not). Scaling off test is a severe test method.

The summarized (accumulated) scaling off losses (g/m<sup>2</sup>) have been calculated for all (concrete + steel) material, then only for steel fibres (separating them with a magnetic rod) and finally normalized (idealized) loss was calculated, adding a surplus concrete loss to the real loss (where concrete volume corresponded to a mass equal to the mass of loosened and scaled steel fibres). This total (normalized) loss is indicated in Fig. 5 and in a more descriptive way in Fig. 6.

The different FRCs (NA or KA with 25, 50, 75 kg/m<sup>3</sup> fibre content) showed similar losses between 400 to 1000 g/m<sup>2</sup> up to 28 days = 28 cycles. Consequently, all of them complies to the EN 1338:2002 European Standard which is valid for concrete pavement elements tested up to 28 days (28 cycles). This specification is, however, misleading because of the rapidly increasing scaling off losses after 28 cycles. Studying the column diagram of Fig. 6 the apparently randomly deviating scaling off results give a clear conclusion. In Fig. 6 scaling off results after 56 days (56 cycles) are represented in an increasing order. It can be realised, that the best four results (<1000 g/m<sup>2</sup> 56d) are provided by specimens of the highest fibre content (average 62.5 kg/m<sup>3</sup>) and the worst four results (>5000 g/m<sup>2</sup> 56d) are provided by specimens of the smallest fibre content (average 37.5 kg/m<sup>3</sup>). Therefore:

- increasing fibre content brakes the scaling off irrespectively of the given two strength classes (KA or NA),
- fibres themselves can not provide frost resistance to the given two strength classes (KA or NA), nevertheless, these strengths can not be considered low strength,
- air entraining agent is needed for a frost resistant FRC,
- the studied FRC specimens did not meet the requirements of any of the used testing methods or standards after 56 freeze-thaw cycles.

Testing with the developed *method A and B* (which are more severe than the standard methods), the loss of mass has reached and exceeded 5 m% for zero, 25 and 50 kg/m<sup>3</sup> fibre content. Only 75 kg/m<sup>3</sup> fibre content gave a loss of mass lower than 5 m%. Increasing fibre content results in a decreasing loss of mass, so adding fibres is not useless, nevertheless, an expectedly sufficient surface condition can not be provided.

### 3.3. Studies on the split surfaces of the Specimens

All slab specimens (L1 to L15) were split and treated with phenolphthalein solution to record the borders of areas with pH value lower and higher than 9. Two split specimens after 56 freeze-thaw cycles are shown in Fig. 7 (specimen of highest scaling off, Fig. 7a; specimen of lowest scaling off, Fig. 7b). Core of the specimens (sound) appears with dark tone (in colour pictures pink) and outer part of the specimens (damaged) appears with pale tone (no colour change by phenolphthalein).

Results indicate that specimens of lower scaling off have a thin external layer of pH <9, on the contrary to specimens of high scaling off, which have a thick layer of pH <9 and only a small sound core. Exposed surfaces of the specimens are indicated with arrows in Fig. 7. The not exposed sides of the specimens were protected by a waterproof heat insulation cover during the 56 cycles, therefore, were not able to become carbonated. Also, the exposed surfaces were covered with the NaCl solution during the 56 cycles and were not able to become carbonated. Reasons for the change in pH value are studied in Chapter 7.

In spite of the sufficient strength (residual splitting tensile strengths were found to be > 2 N/mm<sup>2</sup>, see Table 2) the surfaces themselves were unacceptable.

A complying limit for the split specimens of 2 N/mm<sup>2</sup> splitting tensile strength was arbitrarily chosen, as this limit is sometimes required to decide whether an abraded concrete pavement surface is yet suitable to be renewed with a coating layer. Our results indicated > 2 N/mm<sup>2</sup> strength belonging to all of the control (NF) specimens. After 56 cycles, the uncovered steel fibres got light rust, after NaCl solution was removed and so could contact with O<sub>2</sub>, CO<sub>2</sub> and Cl<sup>-</sup>. Residual splitting tensile strength results indicate that in spite of the worn surfaces of the specimens, the still embedded fibres remained effective inside the material.

## 4. WATERTIGHTNESS: A POSSIBLE INDEX TO DURABILITY

Being on the safe side, the KA specimens ( $w/c = 0.54$ ) were used to check watertightness of FRC with 25, 50, 75  $\text{kg/m}^3$  fibre content. After applying 6 bar water pressure for 72 hours on frost tested (F) specimens we measured penetrations of 6 to 28 mm which corresponds to exposure class  $\text{XV2(H)}$  in Hungary (acc. to MSZ 4798-1:2004; limiting water transmittance is  $0.2 \text{ l/m}^2/24\text{h}$ ).

As a check we also tested 4 years old (laboratory condition stored, control NF) specimens applying 6 bar water pressure for 72 hours. Results were found to be satisfactory. In the case of KA specimens (with a relatively low cement paste content of  $260 \text{ litre/m}^3$ ) the fibre content of  $75 \text{ kg/m}^3$  resulted in a badly compactable concrete, with a high air void content and inadequate watertightness, but no compacting problems were realized for NA specimens of higher cement paste content of  $300 \text{ litre/m}^3$ . Our experiences call the attention that the relatively expensive steel fibres are advised to be added only to higher grades concretes with sufficient cement paste content and therefore perfect workability. Otherwise the efforts remain useless.

A further control test was carried out on 10 years old (laboratory condition stored, control NF,  $50 \text{ kg/m}^3$  fibre content) specimens applying 6 bar water pressure for 6 days (rather than 72 hours = 3 days). Both water penetration depth ( $b_{\text{max}}$ ) and carbonation depth ( $c_{\text{max}}$ ) were measured. Results are:

- KA-I 50/a (Dramix,  $50 \text{ kg/m}^3$ )  
 $b_{\text{max}} = 9 \text{ mm}$ ;  $c_{\text{max}} = 10 \text{ mm}$
- KA-I 50/b (Dramix,  $50 \text{ kg/m}^3$ )  
 $b_{\text{max}} = 11 \text{ mm}$ ;  $c_{\text{max}} = 10 \text{ mm}$
- KA-II 50 (D&D,  $50 \text{ kg/m}^3$ )  
 $b_{\text{max}} = 8 \text{ mm}$ ;  $c_{\text{max}} = 14 \text{ mm}$

Nevertheless our main purpose was to check the condition of fibres after splitting, we could also realize that the water penetration depth values are somewhat lower than the carbonation depth values. We could find that the steel fibres (which have been embedded during the storage time of 10 years under a relatively dry laboratory condition) were *absolutely sound*, with dull grey unstained surface even if they lay in the carbonated region of the specimen (Fig. 7c).

Evaluating our results it was demonstrated that due to crack arrest the high fibre dosage may result in better watertightness (thus also better durability) if perfect embedding (paste content), workability and so perfect compaction is ensured.

## 5. MONITORING OF DETERIORATION DUE TO FREEZE-THAW AND DE-ICING AGENT

### 5.1. Young's modulus and stress-strain responses in compression

The  $E_0$  initial Young's moduli of our  $75 \times 75 \times 150 \text{ mm}$  (1:2) prisms (sawn from bigger beams) have been measured before freeze-thaw cycles (condition NF) and after (condition F) too. Partly strain gages, partly mechanical deformeters were used to record strains (Erdélyi, 2004; Erdélyi, Borosnyói, 2005a). Results are summarized in Table 3.

As an example, Fig. 8 shows a stress-strain ( $\sigma$ - $\epsilon$ ) response

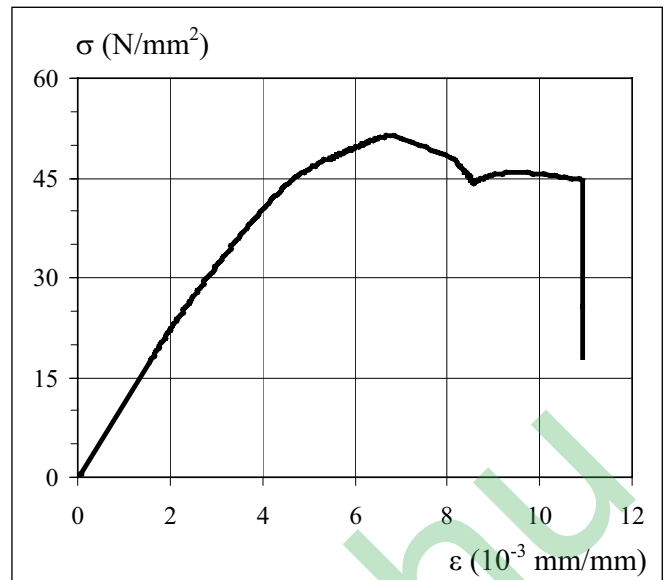

Fig. 8: Stress-strain response of KA specimen ( $25 \text{ kg/m}^3$  fibre content) after 32 freeze-thaw cycles (method A).

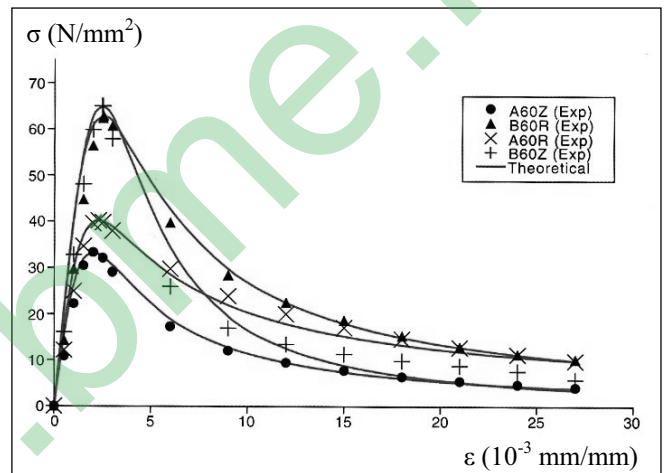

Fig. 9: Stress-strain responses of two different concrete grade FRCs with  $60 \text{ kg/m}^3$  fibre content. (Neves, Almeida, 2005)

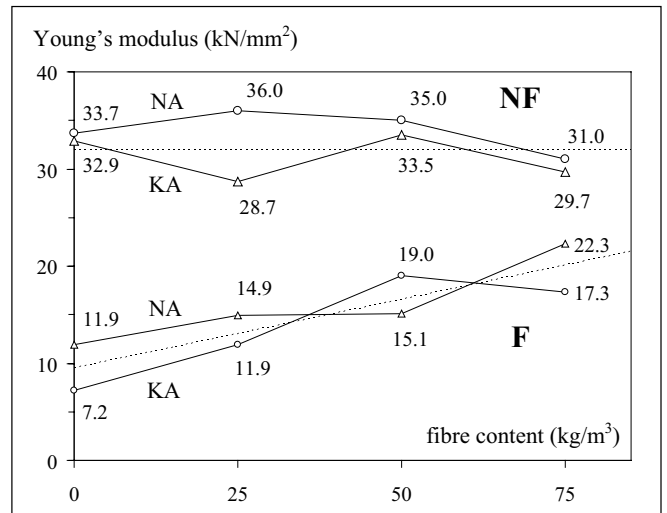

Fig. 10: Young's moduli of specimens before (condition NF) and after (condition F) 32 freeze-thaw cycles tested with the severe method A (selected both NA and KA specimens).

gained with deformeters in an Instron universal testing machine strain controlled. This selected example contained  $25 \text{ kg/m}^3$  fibres and was found to behave soft, more tough, due to the microcracking after 32 freeze-thaw cycles. Generally speaking, all of our ultimate compressive strains lag behind the more tough ones reported in technical literature (e.g. Fig. 9 Neves, Almeida, 2005).

**Table 3:** Young's modulus and compressive strength of specimens before and after 32 freeze-thaw cycles according to method A (average values)

Type	Fibre cont. kg/m <sup>3</sup>	Initial Young's modulus before freeze-thaw cycles E <sub>NF,0</sub> , kN/mm <sup>2</sup>	Initial Young's modulus after freeze-thaw cycles E <sub>F,0</sub> , kN/mm <sup>2</sup>	Compressive strength after freeze-thaw cycles f <sub>cm,F</sub> , N/mm <sup>2</sup>
KA	0	32.9	11.9	28.7
	25	32.3	10.9	54.0
	50	32.1	15.7	43.5
	75	29.7	19.1	45.8
NA	0	33.9	7.3	37.7
	25	30.4	10.7	43.2
	50	35.0	19.1	33.9
	75	28.6	20.3	48.0

Fig. 10 summarize our results on Young's moduli as follows:

- From both NF and F test results we may conclude that all NA (w/c = 0.42) specimens (zero, 25, 50, 75 kg/m<sup>3</sup> fibre content) may be considered as one single population with a mean Young's modulus of E<sub>0,NF</sub> = 34 kN/mm<sup>2</sup>. After freeze-thaw cycles of the severe method A the Young's moduli were found to be E<sub>0,F</sub> = 11.9, 14.9, 15.1 and 22.3 kN/mm<sup>2</sup>, respectively. The loss is 65 to 35% in initial Young's modulus according to the fibre content.
- If all KA (w/c = 0.54) specimens (zero, 25, 50, 75 kg/m<sup>3</sup> fibre content) are considered as one single population, the mean Young's modulus is E<sub>0,NF</sub> = 32 kN/mm<sup>2</sup>. After freeze-thaw cycles of the severe method A the Young's moduli dropped to E<sub>0,F</sub> = 7.2, 11.9, 19.0 and 17.3 kN/mm<sup>2</sup>, respectively. The loss is 80 to 40% in initial Young's modulus according to the fibre content (just for comparison, the KA (w/c = 0.54) specimens as one population yield a mean compressive strength of f<sub>cm,NF</sub> = 48.3 N/mm<sup>2</sup> and f<sub>cm,F</sub> = 47.6 N/mm<sup>2</sup> that are the same, however, the scatter of prism strength after freeze-thaw cycles range from 29 to 58 N/mm<sup>2</sup>).
- It can be concluded that E<sub>0</sub> drops significantly due to freeze-thaw cycles with method A. It means that micro-cracking and internal decomposition occurred. This opinion is supported also with the definitely higher scatter of strength results after freeze-thaw cycles.

The results with the less severe method B were somewhat different. Comparing the lot of the NF condition KA (w/c = 0.54) specimens' results with the F condition specimens' results we can get E<sub>0,NF</sub> = 32 kN/mm<sup>2</sup> and E<sub>0,F</sub> = 31 kN/mm<sup>2</sup>. However, here considering the results as one single population is again not a true approach: for specimens with 25 kg/m<sup>3</sup> fibre content the loss in E<sub>0</sub> is 25%, while those with 50 and 75 kg/m<sup>3</sup> fibre content is almost negligible (2%) or even a gain. Similar paradox was reported in the technical literature too (Feldrappe, Müller, 2004). Our opinion is that the supplementary water (NaCl solution) storage of freeze-thaw tested specimens may give a surplus curing effect during late hardening with a result of less micro-cracks testing specimens of higher fibre content with the less severe method B.

## 5.2. Ultrasound pulse velocity measurements

Ultrasound pulse velocities (UPV) were recorded and analysed in details in this research project. Our 75×75×150 mm prisms provided the results to be analysed to find coherence among:

- fibre content,
- NaCl solution saturation,
- wet or dry conditions,

**Table 4:** Chloride ion content of specimens after 32 freeze-thaw cycles according to method A (selected values)

Property	Fibre content kg/m <sup>3</sup>		
	25	50	75
SiO <sub>2</sub> content (hydrochloric acid soluble), m%	1.70	3.67	1.54
Cl <sup>-</sup> ion content, m%	0.20	0.41	0.24
Ratio Cl <sup>-</sup> /SiO <sub>2</sub>	0.12	0.11	0.16

- concrete grade (KA or NA specimens), and
- NF or F conditions.

As the most important consequence (see Fig. 11), we can call the attention to the influences that can hide the evident deterioration after freeze-thaw cycles (drop in UPV) during measurements. In present experimental tests UPV was found to be significantly decreased after freeze-thaw cycles in specimens oven dried before UPV measurements. On the contrary, for NaCl saturated condition such a decrease can not be realised. One should note that ultrasound pulse velocity measurements can be applicable only for dried condition. Further details can be found elsewhere (Erdélyi, 2004; Erdélyi, Borosnyói 2005a; Erdélyi, Borosnyói, 2005b).

## 5.3. Chloride-ion content of the specimens

Chloride-ion content of three specimens (NA; w/c = 0.42; 25, 50, 75 kg/m<sup>3</sup> fibre content) were analysed after 32 freeze-thaw cycles of the severe method A. As the considerably deteriorated condition of these specimens made impossible to take samples from different depths, we determined the average Cl<sup>-</sup> ion contents of the specimens. We used the Mohr-type argentometric analysis. The Cl<sup>-</sup> ions were dissolved by 2% nitric acid solution from the prepared specimens. Results

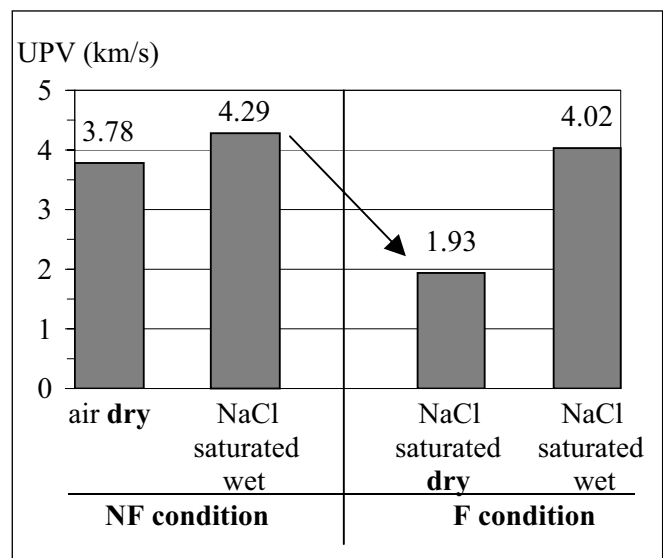

**Fig. 11:** Ultrasound pulse velocity results for a selected group of 50 kg/m<sup>3</sup> fibre content NA specimens, before (NF condition) and after (F condition) 32 freeze-thaw cycles by method A.

are summarized in Table 4. It can be seen that considerable differences were found between the measured values of hydrochloric acid soluble parts and also in silica-dioxide parts. Therefore, we also calculated the Cl<sup>-</sup> ion contents corresponding to the silica-dioxide content. In this way it can be realised, that the Cl<sup>-</sup> ion content is the highest for FRC specimen of 75 kg/m<sup>3</sup> fibre content due to highest air void



content by inadequate compaction for present relatively low cement paste content of 260 litre/m<sup>3</sup>.

## 6. SPECIFIC ELECTRICAL RESISTANCE

Based on literature review and also by Fig. 12 it can be concluded that the specific electrical resistance (SER, Ωm) of concrete and of FRC should be considered a very important measure in durability studies. SER of a concrete of C30/37 is around 10<sup>3</sup> Ωm at 1 m% water content, however, it drops to 100 Ωm if the water content is increased to 5 m% (Balázs, Tóth, 1997).

Our results indicated in Fig. 12 can be selected for different conditions: the apparent porosity (V%) vs. SER (Ωm) responses for dry specimens without any NaCl solution immersion are indicated in Fig. 13, and the apparent porosity (V%) vs. SER (Ωm) responses for wet specimens saturated with NaCl solution are indicated in Fig. 14.

SER of control concrete specimens in dry condition for KA is ~14000 Ωm (w/c = 0.54, porosity > 7 V%) and for NA is ~7000 Ωm (w/c = 0.42, porosity < 3.5 V%). Due to fibre content SER has dropped below 1000 Ωm independently of the nominally 25, 50 or 75 kg/m<sup>3</sup> fibre content.

If the specimens are saturated with NaCl solution the SER is 200 to 400 Ωm for FRCs and ~500 Ωm for control, plain concrete specimens. In the NaCl solution saturated condition differences in SER are negligible.

If a FRC is saturated with NaCl solution and then dried completely, the increase in the SER is negligible (~400 Ωm), however, in case of plain concrete the increment is more visible (for KA ~700 Ωm, for NA ~1200 Ωm). It is also remarkable that in this condition the higher porosity of the concrete results in a higher NaCl content and therefore lower SER (concrete KA), and the lower porosity of the concrete results in lower NaCl content and therefore higher SER (concrete NA).

For the corrosion resistance of concrete structures (reinforced concrete or FRC) a high specific electrical resistance (SER, Ωm) is needed, that can be provided with:

- a lower w/c and therefore lower porosity,
- a quasi-permanent dry condition (prevention against water saturation by means of insulation or water repellent coatings and drainage of water),
- application of steel fibres decreases the SER from plain concrete of 7000 to 14000 Ωm down to FRC of 200 to 400 Ωm independently of the 25, 50 or 75 kg/m<sup>3</sup> fibre content.

## 7. CHANGES IN THE MINERALOGICAL COMPOSITION OF CEMENT STONE

The results on strength and durability of FRC specimens are explained here with mineralogical phase analyses. The loss of strength was caused by modification of hydrated cement phases. The hydrate phases and the changes in mineralogical composition of cement stone were examined using X-ray

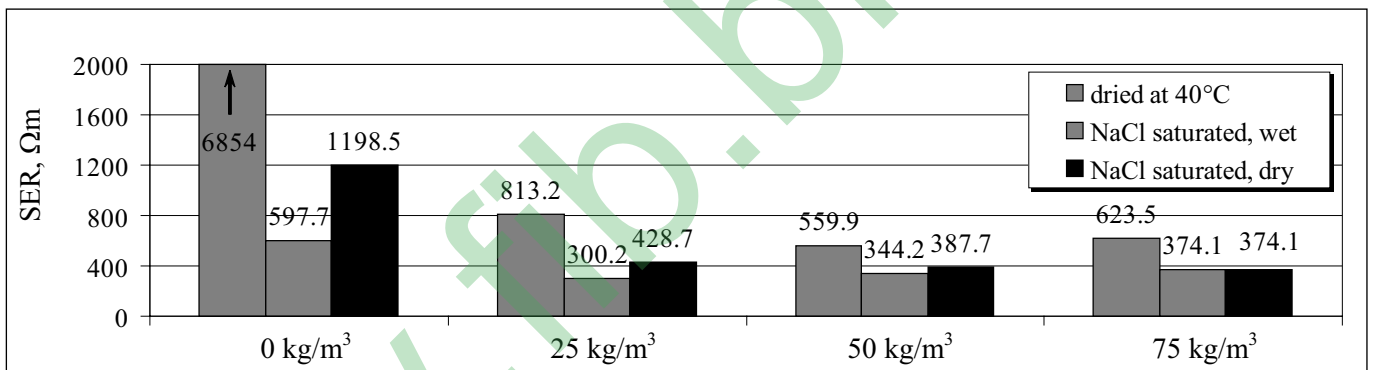

Fig. 12: Specific electrical resistance (SER, Ωm) of steel fibre reinforced concrete specimens (series NA; w/c = 0.42; c = 400 kg/m<sup>3</sup> CEM I 42.5; zero, 25, 50, 75 kg/m<sup>3</sup> fibre content) (Erdélyi, 2004)

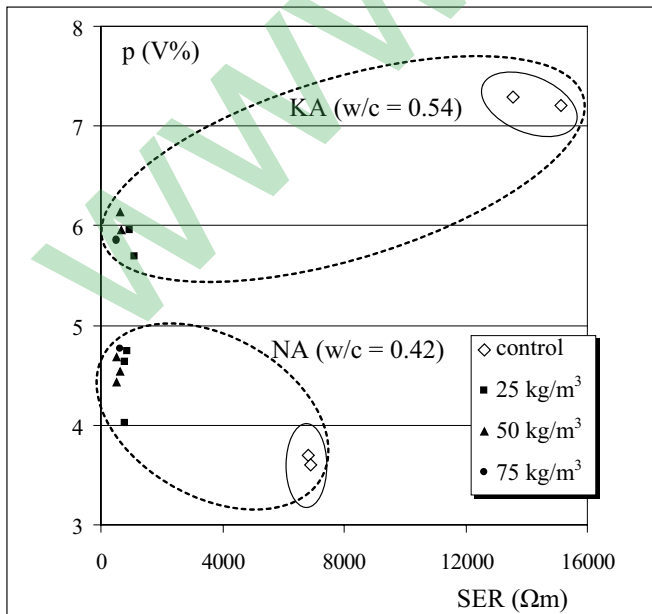

Fig. 13: Specific electrical resistance (SER), apparent porosity and fibre content (never NaCl treated, dry specimens)

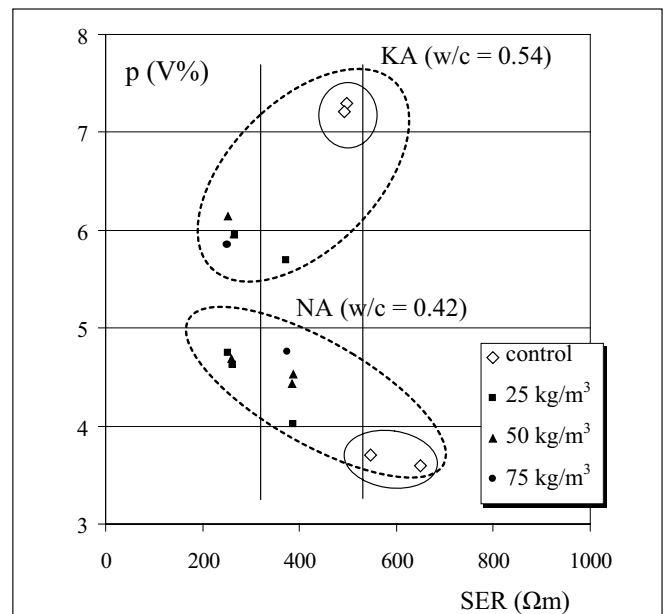

Fig. 14: Specific electrical resistance (SER), apparent porosity and fibre content (saturated with NaCl solution, wet specimens)

diffraction (XRD) with Philips PW 3710 diffractometer and differential thermo analyses (TG/DG/DTA) with Derivatograph Q-1500 D. Simultaneous application of these two analytical methods made possible to carry out detailed analysis of phase modifications.

### 7.1. Aims of mineralogical studies

Carbonation of cement stone is usually studied with phenolphthalein solution dropping or spraying. The phenolphthalein solution is colourless and contacting with alkaline compounds the colour changes to violet. The indicated pH value is around 9. With ordinary Portland cement the pH value of the cement stone is 12.3 and with blended cements the pH value is much lower. The high pH value in cement stone is provided by both the formation of portlandite ( $\text{Ca}(\text{OH})_2$ ) and the contents of alkali metal oxides.

The change in colour of phenolphthalein solution indicates the depth of concrete where the pH value is equal with, or lower than 9. Different terms were used to indicate the carbonated and the non-carbonated cement stone:

- *phenolphthalein positive regions*, where the colour of the indicator changed to violet (pH value above 9),
- *phenolphthalein negative regions*, where the colour of the indicator did not change (pH value equals with 9 or below 9).

In present studies CEM I 42.5 (Bélapátfalva Cement Factory) was used. It is a moderately sulphate resistant cement, which has much more  $\text{C}_4\text{AF}$  aluminate clinker mineral in cement composition than  $\text{C}_3\text{A}$ .

Generally, the chloride ion binding capacity is lower in case of using ordinary Portland cement comparing to blended cements. Smallest chloride ion binding capacity was found in case of sulphate resistant Portland cements due to their very low amount of tricalcium-aluminate ( $\text{C}_3\text{A}$ ). The main aluminate clinker mineral of sulphate resistant Portland cements is tetracalcium-aluminate-ferrite ( $\text{C}_4\text{AF}$ ) of which chloride ion binding capacity is much lower than that of tricalcium-aluminate ( $\text{C}_3\text{A}$ ) (Kopeckó, Balázs, 2005; Kopeckó, 2006).

The chemically bound chloride-containing phase (called Friedel-salt  $\text{C}_3\text{A}\cdot\text{CaCl}_2\cdot\text{H}_{10}$ , Friedel, 1897) decomposes if the cement stone is carbonated. Carbonation is resulted in a drop of pH value from 12.3 to 9.0 or below. The pH value of the pore solution affects the stability of calcium-silicate-hydrate (CSH) phases, which give the strength. The stability of CSH phases is risked by a decreasing pH value.

Aims of mineralogical studies were to answer the following questions:

- Have the phenolphthalein negative regions become carbonated after the freeze-thaw cycles and after the salt-treatment?
- Which mineralogical changes happened in the cement stone in phenolphthalein negative or in phenolphthalein positive regions?
- Is there any connection between the mineralogical changes in the cement stone and the durability of the concrete?
- Which other influences can be originated from freeze-thaw cycles and salt-treatment?

### 7.2. Preparation of samples for phase analyses

Three specimens were selected for phase analyses. The samples were prepared with pulverising the cement stone (or mortar)

cleaned from the aggregate particles and steel fibres. Both phenolphthalein negative and positive samples were taken from each specimen. The specifications of the selected specimens are as follows:

*Sample-1 (L9-NA)*: from the specimen L9-NA25-9a ( $w/c=0.42$ ;  $c=400\text{ kg/m}^3$ ),  $25\text{ kg/m}^3$  steel fibre content – *scaled-off specimen* according to prEN 12390-9:2002.

*Sample-2 (F6-NA)*: from the specimen F6-NA25 ( $w/c=0.42$ ;  $c=400\text{ kg/m}^3$ ),  $25\text{ kg/m}^3$  steel fibre content – *scaled-off specimen* according to the developed *method A* with 32 cycles applied.

*Sample-3 (control NA)*: from a control specimen NA25 ( $w/c=0.42$ ;  $c=400\text{ kg/m}^3$ ),  $25\text{ kg/m}^3$  steel fibre content – *no freeze-thaw cycles and no NaCl treatment was applied*.

### 7.3. Results and discussion

Generally, the amount of portlandite was *not measurable* in the *phenolphthalein negative regions* of NaCl solution treated specimens due to the diluting effect (see selected results for derivative thermo-gravimetric (DTG) curves in Fig. 15 and for X-ray diffraction (XRD) curves in Fig. 16).

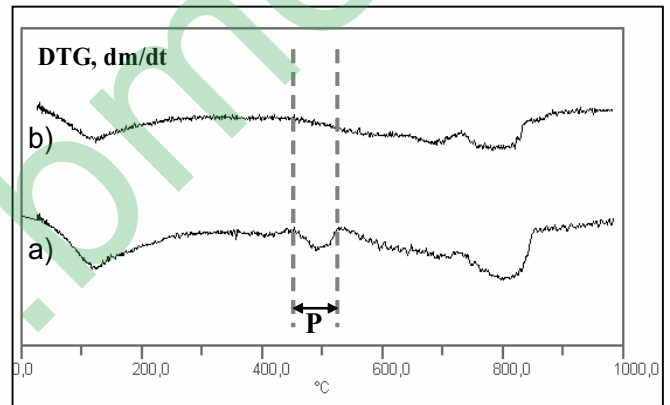

**Fig. 15:** Derivative thermo-gravimetric (DTG) curves of a selected  $25\text{ kg/m}^3$  fibre content NA specimen after 32 freeze-thaw cycles by method A. a) phenolphthalein positive region (pH > 9) b) phenolphthalein negative region (pH < 9)

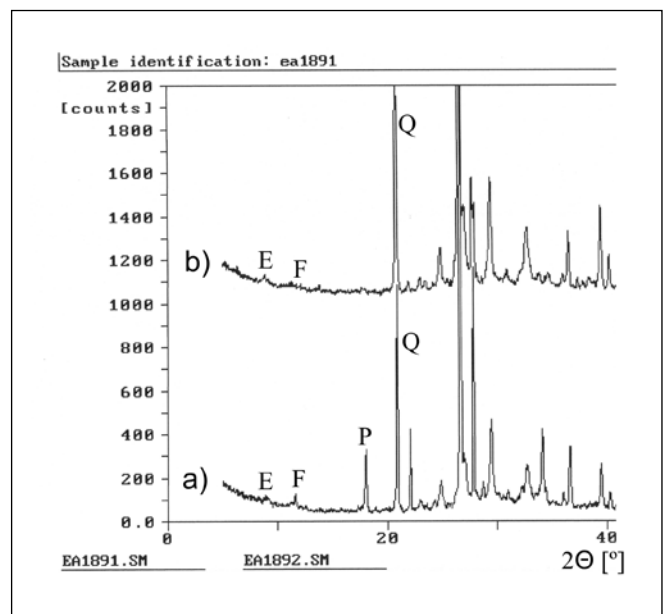

**Fig. 16:** X-ray diffraction (XRD) curves of a selected  $25\text{ kg/m}^3$  fibre content NA specimen after 32 freeze-thaw cycles by method A. (E – ettringite, F – Friedel-salt, P – portlandite, Q – quartz) a) phenolphthalein positive region (pH > 9) b) phenolphthalein negative region (pH < 9)

On the contrary, 1.4 m% portlandite content was found in the phenolphthalein negative region of control specimen (changes only by carbonation under laboratory conditions). Lower thermo gravimetric total loss of mass due to dehydration was found in the phenolphthalein negative regions of NaCl solution treated specimens. It means that the hydrate phases of cement stone are partly *decomposed* and are not stable anymore. The amount of both calcium-silicate-hydrate (CSH) and Friedel-salt decreased in the phenolphthalein negative regions.

The amount of portlandite was higher in the *phenolphthalein positive regions*. The stability and the strength of this region were provided by the higher amount of portlandite. More  $\text{CaCO}_3$  was found in the phenolphthalein positive region being stored long time under laboratory conditions (and originated from the higher amount of portlandite).

Both phenolphthalein positive and negative regions became *carbonated*.

The chloride containing hydrate phase (*Friedel-salt*) was found both in the phenolphthalein positive and negative regions. The intensity of X-ray pattern of Friedel-salt was higher in the phenolphthalein positive region, although this region was not in direct contact with the NaCl solution. Of course, formation of Friedel-salt was not possible in the control specimen (lack of chloride ions).

Generally, in present experimental studies the most important reason impairing the stability of CSH and CAH phases was identified as the *dilution of portlandite*, i.e.  $\text{Ca}(\text{OH})_2$ .

## 8. OVERALL CONCLUSIONS

### 8.1. Aims and methods

In present experimental research we tested and evaluated the durability of SFRC specimens, which – intentionally – were cast with moderately sulphate resistant cement (CEM I 42.5 N) and without air-entraining agent. The beneficial effect on durability of the entrained air-void system was therefore excluded, as well as the behaviour of a relatively frost sensitive cement have been studied. The aim of our experimental research work was to clear up how does steel fibre dosage (zero, 25, 50, 75  $\text{kg/m}^3$ ; type 30/0.5) influence the durability of FRC. Mainly freeze-thaw and de-icing agent resistance, and water-permeability were tested and it was recorded whether fibres remain sound and effective also after exposure.

We also assessed the specific electrical resistance (SER,  $\Omega\text{m}$ ) of differently treated FRC specimens in different conditions and with compositions (fibre and cement content, water-to-cement ratio; control dry stored, NaCl saturated or not, wet or dry, etc). These parameters are not frequently studied together, however, they essentially determine the general corrosion behaviour of FRC structures. Beside the most severe freezing-thawing method *scaling off* (prEN 12390-9:2002) we have evaluated the loss of mass, furthermore the changes in initial Young's modulus  $E_0$ , in ultrasound pulse velocity (UPV) and in  $\sigma$ - $\varepsilon$  diagrams due to freeze-thaw cycles. Modified methods for freeze-thaw tests have been developed applying specimens immersed into NaCl (3 m%) solution up to their half thickness: *method A* (rotated specimens) and *method B* (not rotated specimens).

In general, it can be concluded that our results are in agreement with the technical literature on scaling off: the reasons, mechanism and phenomena of deterioration is not the same as in the case of internal frost damage (e.g. Valenza, Scherer, 2007).

## 8.2. Conclusions for concrete technology

FRC with  $f_{cm} = 45$  to  $65 \text{ N/mm}^2$  is not frost and de-icing agent resistant if it is not air entrained. Steel fibre dosage itself cannot improve resistance considerably: therefore the relatively expensive FRC structures should be made with a suitable spherical air void system if exposure to frost and de-icing agent is expected.

The *scaling off method* according to prEN 12390-9:2002, and our developed *method A* and *method B* are more severe than the traditional freeze-thaw testing methods using completely immersed specimens and determining only loss of mass and loss of strength. The studied methods enable a continuous capillary supply of NaCl and parallelly the diffusion of oxygen and carbon-dioxide into FRC. The 28 cycles tests even with scaling off method are not sufficient to assess real frost resistance, therefore such standards (EN 1338:2002 for concrete paving stones) are misleading and are on the unsafe side.

Only FRC mixes of perfect workability and with the very same grade of realized compaction can perform expectedly and should be compared experimentally: *higher fibre dosage needs higher paste content and more superplasticizer*.

Fibre content usually do not reach the theoretical value of mix design if they are determined from smaller specimens cast in mould.

### 8.3. Mechanical parameters

Due to freeze-thaw cycles the initial Young's modulus (from  $E_{0,NF}$  to  $E_{0,F}$ ) drops with almost 80 percent for plain concrete and 30 to 40 percent for FRC. The scatter of values is very high.

The prism compressive strength is less impaired at the same time.

Splitting tensile strength also decreases due to freeze-thaw cycles but fibre dosage is effective from this respect (opposing with that no-effect in compression), and load bearing capacity in tension still remains high (though the surface condition is unacceptable).

Fibres embedded do not rust and those separated from the matrix during scaling off anyhow do not exert pressure and do not cause cracks. The amount of steel wires loosened and scaled off during the tests is much less than it would be derived from mix ratio. *Increased fibre dosage decreases the scaling off values*.

Watertightness is a primer precondition for durability and water penetration values even after frost cycles were complying with requirements ( $\leq 20 \text{ mm}$  or  $\leq 40 \text{ mm}$ ). Fibres are hindering microcracking and internal strains and thus in spite of internal damage (see the drop of  $E_{0,F}$ ) the mass (volume) of FRC remains watertight as a whole. This does not result simultaneously in an acceptable surface.

The ultrasound pulse velocity (UPV,  $\text{km/s}$ ) is directly influenced by the type of coupling material: the best of them is machine grease and Vaseline, a bentonite suspension is acceptable, others (e.g. water) should be avoided (Nehme, 2007). UPV will drop due to freeze-thaw cycles and to stay on the safe side it is advisable to measure UPV only after the specimens have *dried* out. Physical conditions do influence the UPV values but fibre content (up to our  $75 \text{ kg/m}^3$ ) apparently does not.

## 8.4. Specific electrical resistance

The overall susceptibility to corrosion of FRC or reinforced FRC is expectedly *increased* because the overall specific electrical resistance (SER,  $\Omega\text{m}$ ) is decreasing due to steel fibres. The wetter and the more NaCl saturated the FRC, the bigger the drop.

It should be advised therefore to keep the inner part of our RC (FRC) structures dry as far as possible: using e.g. hydrophobized cements, water repellent coatings, small water-to-cement ratio and drainage of rainwater etc; these all will serve the durability of structures

## 8.5. Mineralogical and chemical parameters

Chloride ion content  $\text{Cl}^-$  is negligible in 10 years old FRC samples if never touched with salt. Specimens lying in NaCl solution and tested by freeze-thaw cycles contain 1.5 to 2.0 m%, which is less than measured in maritime RC structures (in the Netherlands) in the splash zone.

With detailed chemical analyses we assessed that the really important ratio of  $\text{Cl}^-/\text{SiO}_2$  of hardened cement paste will *increase* with increasing volume of air voids left in the concrete due to poorer compaction and due to difficulties of higher fibre dosages.

The external regions of specimens that were exposed directly to freeze-thaw and to the step by step renewed NaCl solution (scaling off method) have completely lost their  $\text{Ca}(\text{OH})_2$  (portlandite) content, nevertheless, carbonation was excluded. This means also chemical instability and mechanical decomposition: it seems that renewed NaCl solution can dilute the most important part of concrete, the portlandite. It might be important to check, whether such renewed NaCl solution also without frost effect could cause similar deterioration (see COMPASS project, the Netherlands).

## 9. ACKNOWLEDGEMENTS

The project leader of this research work OTKA T032883 (Attila Erdélyi) announces his sincere thanks and gratitude to the Hungarian Research Fund and to its director Mrs. Elemérné Gilyén and her project officer Mrs. T. Mária Nagy for the financial support and continuous readiness in cooperation.

Similarly the project leader's thanks rightly turns to *the co-authors* for their independent work in research, testing, evaluation, structuring the conclusions, etc.

The authors are altogether expressing their thanks to the professional team of the Department of Construction Materials and Engineering Geology, Budapest University of Technology and Economics, namely to: assoc. prof. dr. Zsuzsanna Józsa, senior lecturers dr. Salem Nehme and dr. István Zsigovics, lab. engineer Gyula Emszt, technicians József Péter, István Mikes, Viktória Rónaky, Endre Árpás, László Bene, Erzsébet Saskői, furthermore, senior student Gábor Földvári and research fellow Sándor Fehérvári. All they took full share in their special tasks entrusted with, for several years or shorter periods.

Other experts of the Budapest University of Technology and Economics who took part either in measurements or in advising should receive our thanks: senior research fellow dr. Miklós Kálló, DSc János Ujhelyi, prof. Miklós Gálos, hon. prof. Tibor Kausay and last but not least the Head of our Department prof. György L. Balázs.

The cooperating other institutes helping us with special

measurements (electrical resistance, sulphate resistance, etc.) were: ÉMI Ltd. (dr. Károly Kovács, Mrs. Katalin Pásztor, Mrs. Eszter Pétery, Sándor Takács, Sándor Boros), Cemkut Ltd. (Mrs. Éva Szegő, Tibor Gulyás, Antal Király) and Maépteszt Ltd. (research fellow Csaba Gyömbér). Thank you all!

Finally, the project leader's most difficult task is to say sorrowfully the deepest thanks and gratitude to his wife for 41 years Éva Tóth, and bid her good-bye as she passed away during this research project run. The time spent with her in the last years may have been too short as compared with the time which was taken by this research project considered to be important once upon a time, but not any more today, *sub specie aeternitatis*.

## 10. REFERENCES

- Balázs, Gy. (1991) „Corrosion protection of RC bridges“ *BME Dept. of Building Materials*, 1991, p.223. (in Hungarian)
- Balázs, Gy. (2001) „Walks in concrete research“, *Akadémiai Kiadó*, Budapest, pp. 83-102, 120-133. (in Hungarian)
- Balázs, Gy., Tóth E. (Eds.) (1997) „Diagnostics of concrete and reinforced concrete structures“, *Műegyetemi Kiadó*, Budapest, pp. 45-54. (in Hungarian)
- Bekaert S. A. (1988) „Die Dauerfestigkeit von Dramix Stahldrahtfaserbeton“ *Technische Daten*, 1988, pp. 1-8.
- Cao, J., Chung, D. L. (2002) „Damage evolution during freeze-thaw cycling of cement mortar by electrical resistivity measurement“ *Cement and Concrete Research*, 32, 2002, pp. 1657-1661.
- Dauberschmidt, C., Bruns, M. (2004) „Korrosionsmechanismen von Stahlfasern in chloridhaltigem Beton“ *IBAC Mitteilungen*, RWTH Aachen, Inst. für Bauforschung, 2004, pp. 62-64.
- Erdélyi, A. (1993) „The toughness of steel fibre reinforced concrete“ *Periodica Polytechnica*, 1993, Vol. 37., No. 4., pp. 229-244.
- Erdélyi, A. (1994) „Fibre reinforced concretes (OTKA T 016683)“ *Beton*, 1994/3, pp. 4-13. (in Hungarian)
- Erdélyi, A. (1995) „Fibre reinforced concretes (OTKA T 016683)“ *Beton*, 1995/4, pp. 1-6. (in Hungarian)
- Erdélyi, A. (1996) „Durability of concrete and entrained air void system“ *Beton szerkezetek tartóssága*, Konferenciakiadvány, Műegyetemi Kiadó, 1996, pp. 129-138. (in Hungarian)
- Erdélyi, A. (1997) „Toughness of fibre reinforced concrete (OTKA T 016683)“ *BME Építőmérnöki Kar Tudományos Közleményei*, Műegyetemi Kiadó, 1997, 37. szám, pp. 99-106. (in Hungarian)
- Erdélyi, A. (2004) „Durability of fibre reinforced concrete“ *Vasbetonépítés*, 2004/1, pp. 12-20. (in Hungarian)
- Erdélyi, A. (2006) „Fibre reinforced concrete“ *Beton Zsebkönyv*, Duna-Dráva-Cement, 2006, pp. 154-162. (in Hungarian)
- Erdélyi, A., Borosnyói, A. (2005a) „Toughness and durability of steel fibre reinforced concretes“ *Tudományos ülésszak* Palotás László születésének 100. évfordulójára (OTKA T 016683, OTKA T 032883), 2005. január 26-27. (in Hungarian)
- Erdélyi, A., Borosnyói, A. (2005b) „Durability studies on SFRC“, *Proceedings of 1<sup>st</sup> CECCC Fibre Reinforced Concrete in Practice*, 8-9 September 2005, Graz, Austrian Society for Concrete and Construction Technology, 2005, pp. 67-70.
- Fagerlund, G. (1997) „Internal frost attack – State of the Art“, *Frost resistance of concrete*, Eds.: Setzer, M. J., Auberg, R., *E&FN Spon*, London, 1997, pp. 321-338.
- Feldrappe, V., Müller, C. R. (2004) „Auswirkungen einer Frostbeanspruchung auf dichte, hochfeste Betone“ *Beton*, 2004/10, pp. 573-575.
- Friedel, P. M. (1897) „Sur un Chloro-aluminate de Calcium Hydraté se Maclant par Compression“, *Bulletin Soc. Franc. Minéral*, Vol 19, pp. 122-136.
- Harnisch, J. (2004) „Untersuchungen zum Elektrolytwiderstand von KKS (Kath. Korrosionsschutz)“ *IBAC Mitteilungen*, RWTH Aachen, Inst. für Bauforschung, 2004, pp. 126-174.
- Hewlett, C. P. (2004) „Lea's Chemistry of Cement and Concrete“, *Elsevier Butterworth-Heinemann*, Glasgow, pp. 761-763, 962-970.
- Kausay, T. (2001) „ASR in concrete“, <http://www.betonopus.hu/notesz/alkali-reakcio/alkali-reakcio.pdf>.
- Kopecskó, K. (2006) „Chloride ion binding capacity and steam

- curing of clinker minerals and cements" *PhD Thesis*, pp. 82-88. (in Hungarian)
- Kopecskó, K., Balázs, Gy. (2005) „Chloride ion binding of cement clinkers and cements influenced by steam curing”, *Proceedings of fib Symposium “Structural Concrete and Time”*, La Plata 2005, Vol. 1, pp. 147-154.
- Lubelli, B., Hees, R. P. J., Huinik, H. P. (2006) „Effect of NaCl on the hygric and hydric dilation behaviour of lime-cement mortar” *HERON*, Vol. 51., No. 1., 2006, pp. 33-47.
- Maage, M., Smeplass, S. (2001) „Carbonation – A probabilistic approach” *DuraNet*, 3<sup>rd</sup> Workshop, Tromsø, Norway, 10-12 June 2001.
- Nehme, S. G. (2007) “UPV measurements and contact materials”, *personal communication*, Budapest, 2007.
- Neves, R. D., Almeida, J. C. O. (2005) „Compressive behaviour of steel fibre reinforced concrete” *Structural Concrete*, 2005, Vol. 6. No. 1., pp. 1-7.
- Nischer, P. (2000) „Forschungsbericht des Laboratoriums von ÖVZ“, *personal communication*, Wien, April 2000.
- Orgass, M., Dehn, M. (2002) „Industrie Fussboden aus Stahlfaserbeton“ *Faserbeton, Innovationen im Bauwesen*, Beinwerkverlag Berlin, 2002, pp. 213-220.
- ÖVBB (2002) „Faserbeton Richtlinie“ *Österreichische Vereinigung für Beton und Bautechnik*, März 2002, pp. 1-64.
- Polder, R., Rooij, M. R. (2005) „Durability of marine concrete structures – field investigation and modelling” *HERON*, Vol. 50., No. 3., 2005, pp. 133-151.
- Rooij, de M. R., Groot, C. J. (2006) „A closer look on salt loaded microstructure” *HERON*, Vol. 51., No. 1., 2006, pp. 49-62.
- Setzer, M. J., Fagerlund, G., Janssen, D. J. (1996) „CDF Test – Test method for the freeze-thaw resistance of concrete – tests with sodium-chloride solution” *Materials and Structures*, V.29., Nov 1996, pp. 523-528.
- Ujhelyi, J. (2005) „Theory of concrete” *Műegyvetemi Kiadó*, 2005, p. 157. (in Hungarian)
- Valenza, J. J., Scherer, G. W. (2007) “A review of salt scaling: I. Phenomenology, II. Mechanisms”, *Cement and Concrete Research*, Vol 37., 2007, pp. 1007-1021 and pp. 1022-1034.
- Vijffels, T., Lubelli, B. (2006) “Development of a new accelerated salt crystallization test” *HERON*, Vol. 51., No. 1., 2006, pp. 63-79.
- Attila Erdélyi** (1933) civil engineer (MSc, 1956), ret. associate professor, CSc (1984). Construction engineer at Máv Hídépitő Co. to 1961, design engineer at Viziterv to 1963. Assistant professor, and senior lecturer from 1965 (with the leadership of professor Palotás László) at the Department of Building Materials, Budapest University of Technology. Associate professor from 1985, Head of Department from 1991 to 1995. Member of the Hungarian Group of FIP, and then *fib*, leader member of ÉTE Precast Subgroup and SZTE Concrete Subgroup. He received the Palotás Award in 2003. *Main fields of interest*: relaxation of prestressing steel, prestress losses, admixtures, high strength concrete, mass concrete, steel fibre reinforced concrete, self compacting concrete. Hungarian and European standardisation. Lectures in postgraduate, PhD and special courses in Hungarian and in English.
- Erika Csányi** (1945) chemist (JATE, Szeged, Faculty of Natural Sciences), analytical chemist engineer (BME Faculty of Chemical Technology). Research fellow from 1974 to 1984 at ÉTI Department of Chemistry, then from 1984 at the Department of Building Materials, Budapest University of Technology. *Main fields of interest*: analytical chemistry, chemistry of building materials, corrosion and corrosion protection.
- Dr. Katalin Kopecskó** (1961) chemical engineer (MSc, 1990), engineer of concrete technology (2004), PhD (2006). Senior lecturer at the Department of Construction Materials and Engineering Geology, Budapest University of Technology and Economics. *Main fields of interest*: materials testing, phase change analyses and durability studies by thermo analytical (TG/DTG/DTA) and X-ray diffraction (XRD) methods. Member of the Hungarian Group of *fib* and of SZTE.
- Dr. Adorján Borosnyói** (1974) civil engineer (MSc), PhD, senior lecturer at the Department of Construction Materials and Engineering Geology, Budapest University of Technology and Economics. He received the MTA Bolyai János research fellowship in 2006. *Main fields of interest*: serviceability and durability of concrete structures, application of non-metallic (FRP) reinforcements for concrete structures, bond in concrete, strengthening with advanced composites, fibre reinforced concrete. Member of the Hungarian Group of *fib* and member of *fib* TG 4.1 „Serviceability Models”.
- Olivér Fenyvesi** (1981) civil engineer (MSc), research fellow, Department of Construction Materials and Engineering Geology, Budapest University of Technology and Economics. *Main fields of interest*: lightweight concrete, fibre reinforced concrete. He prepares his PhD Thesis in the topic of fibre reinforced lightweight concrete.

# TECHNICAL GUIDELINE FOR RECYCLED AGGREGATE CONCRETE IN HUNGARY



György L. Balázs – Tibor Kausay – Tamás K. Simon

*The Hungarian Group of fib developed a Technical Guideline for concretes by using crushed bricks or crushed concrete. Crushed concrete can originate from demolishing or from prefabrication. This paper presents the main parts of the Technical Guideline including classification of crushed recycling aggregates and the procedure of preparing the concrete with recycled aggregates.*

**Keywords:** recycling, concrete, light-weight concrete, concrete element, aggregate, waste, debris, concrete mix design

## 1. INTRODUCTION

In Hungary, out of construction, demolition and material production a considerable amount of usually not dangerous waste arises, the utilisation of which should be helped if we take into consideration the protection of the environment.

One of the areas of recycling waste arising from construction, demolition and material production is the mixing of concrete, reinforced concrete or possibly prestressed concrete. This is supported by the European concrete and aggregate standards, but they do not deal with the conditions of reusing the waste as aggregate for concrete production. The EN 206-1:2000 standard states that „the aggregates may be natural, artificial or recycled materials from earlier structures”. The range of EN 12620:2002 aggregates for concrete, EN 13139:2002 aggregates for mortar, EN 13043:2002 aggregates for asphalt, EN 13055-1:2002 light-weight aggregates standard is valid for *recycled demolition aggregates*. According to these product standards in case of using such aggregate of which there is not enough experience (like the recycled aggregates), careful testing is to be carried out, and even if having favourable test results may be necessary to prepare unique regulations regarding the range of usability. These aggregate product standards while discussing the harmonisation with the European construction directives, agree in appendix ZA.1 that all the requirement system for aggregates may be amended with further requirements, for example in the form of national requirements, which are valid together with the European standard.

For the effect of these circumstances did the committee of 20 participants (chairman: *Tibor Kausay*) of the Hungarian Group of *fib* (International Federation for Structural Concrete) (chairman: *György L. Balázs*) prepare the “Technical Guideline for concretes by using recycled crushed bricks or crushed concrete”, [BV-MI 01:2005 (H)] Concrete and Reinforced Concrete Technical Guideline, which was issued in the August of 2005 (*Fig. 1*).

The Technical Guideline was prepared by taking into consideration the six basic requirements given in the appendix of *The Construction Products Directive* (Council Directive 89/106/EEC) and the connected Interpretative Document issued on the 28th of February 1994 under the number 94/C 62/01.

The Technical Guideline deals with: the terms and definitions, the raw materials for concrete mixing, the recycled



**Fig. 1:** Cover page of the Technical Guideline (Translation in italics)

aggregate concrete, the concrete products out of recycled construction waste aggregate concrete, the concrete products out of recycled construction material production waste aggregate concrete, the reinforced and prestressed concrete products, the technical conditions of the production and utilisation of recycled aggregate premixed concrete – including the requirements and the tests.

In the appendices it discusses the legal and health regulations regarding handling and utilisation of construction waste, the



**Fig. 2:** Processing of demolition waste (Kiss és Társa Inc. Co., Budapest)

most important technological solutions for processing such waste, the environmental classification of concrete which contains recycled aggregate, gives calculated numerical examples for the evaluation of the compressive strength of concrete, deals with the product certification and the deformation of recycled concrete, gives the bibliographical data of the referred standards, technical guides, literature and laws.

The recycled aggregate concrete is either normal-weight concrete in the C8/10 – C45/55 compressive strength class range, or light-weight concrete in the LC8/9 – LC25/28 compressive strength class range.

## 2. RECYCLED AGGREGATE

The wastes arising from demolition, construction and material production must be adequately processed to make it possible for usage as aggregate for concrete (Fig. 2). To produce a good quality recycled aggregate the selective demolition is indispensable. The separated by type materials must be crushed in several steps to the appropriate size while cleaned from the undesirables like in case of reinforced and prestressed concrete from the steel and tendons, then fractionalised by size. The fractions are to be stored and transported separately. The fractionalized, recycled aggregate is to be fed into the mixer by fractions after batching. The recycling of the concrete material production waste as an aggregate is usually done in the factory where it is generated. The concrete production waste requires exactly the same crushing, fractionalisation and removal of the fine particles as the construction and demolition waste.

From the preparation process only the cleaning may be saved. It is easier to realize the wet fractionalization (washing) of the concrete waste arising from construction material production in the concrete factory then in a mobile processing plant.

The recycled aggregate is to satisfy the requirements of EN 12620:2002 standard regarding normal-weight concrete or EN 13055-1:2002 and the MSZ 4798-1:2004 European and Hungarian standards regarding light-weight concrete about aggregates. By the terms of recycled aggregate the Technical Guideline understands concrete, mixed concrete/brick or crushed brick. The grouping of so prepared aggregates by constituents may be made on the bases of the constituents of the construction materials in the bigger than 4 mm particle size fraction (Fig. 3).

The recycled aggregates and concretes made of them are classified by their dry densities according to Table 1. Based on experiences concrete waste may be considered as normal-weight aggregate, the mixed concrete/brick waste rarely as normal-weight, generally as light weight aggregate, while the brick/concrete and the brick waste as light-weight aggregate. This difference is important from the point of the design of recycled aggregate concretes.

For the recycling of the demolition and construction waste as an aggregate, the following properties are to be determined: the composition by material type and filth content by visual examination, body density (EN 1097-6:2000), bulk density (EN 1097-3:1998), water absorption (EN 1097-6:2000), apparent porosity, particle size and grading (EN 933-1:1997), fineness modulus (MSZ 4798-1:2004), the percentage by volume of the particles under 0.02 mm by sedimentation (MSZ 18288-

**Table 1:** The classification of recycled aggregates and concretes mixed of them based on their dry density properties

	Recycled aggregate		Density of concrete at the age of 28 days, kg/m <sup>3</sup>
	Body density, kg/m <sup>3</sup>	Bulk density, kg/m <sup>3</sup>	
Normal-weight aggregate	2000 < $\rho_b$ < 3000		
Light-weight aggregate	$\rho_b \leq 2000$	$\rho_n \leq 1200$	
Normal-weight concrete			2000 < $\rho_c \leq 2600$
Light-weight concrete			800 $\leq \rho_c \leq 2000$

Remark:  $\rho_b$  notation of body density,  $\rho_n$  notation of bulk density in Hungary

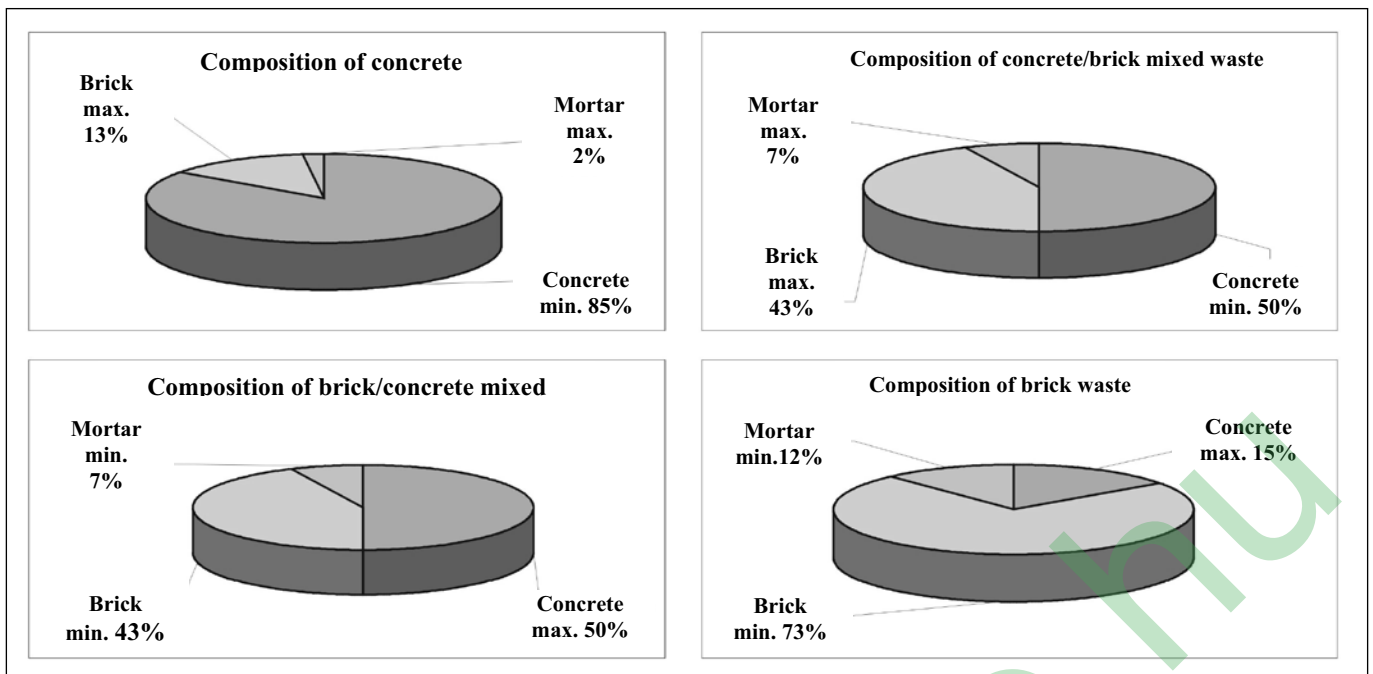

Fig. 3: System of demolition materials usable as concrete aggregate (Hungary, 2005)

Table 2: Physical classification of recycled concrete waste and mixed concrete/brick waste aggregates

Property and test method	Testable aggregate size range <sup>a</sup> , mm	Physical groups in case of <i>alternative-tests</i>						
		<i>Fr-0</i>	<i>Fr-A</i>	<i>Fr-B</i>	<i>Fr-C</i>		<i>Fr-D</i>	
					<i>Fr-C1</i>	<i>Fr-C2</i>	<i>Fr-D1</i>	<i>Fr-D2</i>
Los Angeles fragmentation, mass %	3-80	$a_{LA15} \leq 15$	$15 < a_{LA20} \leq 20$	$20 < a_{LA25} \leq 25$	$25 < a_{LA30} \leq 30$	$30 < a_{LA35} \leq 35$	$35 < a_{LA40} \leq 40$	$40 < a_{LA45} \leq 45$
Micro-Deval fragmentation, wet process, mass %	3-20	$a_{MD10} \leq 10$	$10 < a_{MD15} \leq 15$	$15 < a_{MD20} \leq 20$	$20 < a_{MD25} \leq 25$	$20 < a_{MD25} \leq 25$	$25 < a_{MD30} \leq 30$	$25 < a_{MD30} \leq 30$
Crystallisation fragmentation in MgSO <sub>4</sub> solution, mass %	2-80	$a_{Me5} \leq 5$	$5 < a_{Me10} \leq 10$	$10 < a_{Me15} \leq 15$	$15 < a_{Me18} \leq 18$	$18 < a_{Me21} \leq 21$	$21 < a_{Me25} \leq 25$	$25 < a_{Me30} \leq 30$
The highest compressive strength class of concrete <sup>b</sup>		C35/45	C30/37	C25/30	C20/25	C16/20	C12/15	C8/10
<sup>a</sup> The aggregate size range, which covers the size of the samples. <sup>b</sup> Based on the body density mainly the fractions above 4 mm of the normal-weight recycled aggregate. The fractions below 4 mm partly or totally are of natural sand (and possibly added fine additives). Remark: <i>Fr</i> indicates the physical class for aggregates according to the Hungarian notations								

2:1984), the water soluble sulphate and chloride content of the surface (MSZ 18288-4:1984), *particle shape* by a Vernier calliper (EN 933-4:1999) or a flow funnel (EN 933-6:2001), *frost resistance* (in case of normal-weight aggregate: EN 1367-1:2007, light-weight aggregate EN 13055-1:2002 standard appendix C), and if necessary in case of normal-weight aggregate *de-icing-salt resistance* (EN 1367-1:2007 standard, appendix B).

Since the origin of the *construction material production waste* is known, – if an aggregate contains only maximum 10% recycled aggregate – may be enough to determine only the filth content, the body density, the particle size, the modulus

of fineness and the particle shape. The other properties are defined by the properties of the source concrete, reinforced or prestressed concrete.

Before utilisation the short term water absorption capability of the recycled aggregate must be determined according to EN 1097-6:2000.

## 2.1. Physical properties

Chapter 5. of MSZ EN 12620:2002 transfers the regulation of usage conditions of aggregates — according to physical properties — to national competence.



**Table 3:** The allowed portion of demolition and construction concrete waste and possibly mixed concrete/brick waste in the total amount of aggregate

Grade of normal-weight concrete, wet curing, according to EN 206-1 $f_{ck,cyl}/f_{ck,cube}$	The allowed portion of demolition and construction concrete and mixed concrete/brick waste in mass percentage in the total amount of aggregate						
	The considerable physical group of the demolition and construction concrete and mixed concrete/brick waste aggregate						
	<i>Fr-0</i>	<i>Fr-A</i>	<i>Fr-B</i>	<i>Fr-C1</i>	<i>Fr-C2</i>	<i>Fr-D1</i>	<i>Fr-D2</i>
C8/10	100	100	100	100	100	100	100
C12/15	100	100	100	100	100	100	70
C16/20	100	100	100	100	100	70	30
C20/25	100	100	100	100	70	30	×
C25/30	100	100	100	70	30	×	×
C30/37	100	100	70	30	×	×	×
C35/45	100	70	30	×	×	×	×
C40/50	70	30	×	×	×	×	×
C45/55	30	×	×	×	×	×	×
C50/60	×	×	×	×	×	×	×

Notation: × Usage of demolition and construction material production waste is not suggested

The normal-weight recycled *concrete* or *mixed concrete/brick* aggregates, originating from *demolition* or *construction*, depending on the results of Los Angeles, micro-Deval and magnesium-sulphate tests should be classified by their *physical properties* as given in *Table 2* according to MSZ 4798-1:2004 into *physical groups*. The system of the physical groups is based on the system of EN 12620:2002 standard. The recycled aggregate may be classified into any of the physical groups if the tests were carried out on the same sized test portion, originating from the same laboratory sample and the material satisfies all the requirements of the physical group in the same time.

The European standards require to carry out these „reference-tests” which are necessary for the classification on samples of particle size 10-14 mm. According to MSZ 4798-1:2004 Hungarian standard the properties of recycled aggregate are to be determined on the so called „alternative-sample” which is a graded aggregate fraction, more precisely on the test sample from it.

If during the acceptance of the frost resistance of the recycled aggregate we are not satisfied with the results of the magnesium sulphate test according to EN 1367-2:1999, then during the direct frost resistance tests according to EN 12620:2002 the climatic conditions of Hungary are to be considered as

continental. That is, if the environmental class designation of the concrete out of recycled aggregate is XF1, then the frost resistance class of the aggregate should be at least  $F_2$  or  $MS_{25}$ , and if it is XF2, XF3 or XF4, then the frost resistance class of the aggregate should be at least  $F_1$  or  $MS_{18}$ .

The demolition and construction concrete waste and demolition and construction mixed concrete/brick waste proportion in the total aggregate in the function of the physical group and the compressive strength class of the concrete is according to *Table 3*.

In the aggregate mixture is only allowed to use recycled material in a bigger portion than the values given in *Table 3* if it is proved by laboratory tests that the compressive strength class of the concrete satisfies the prescribed one.

If the quality of the recycled waste from demolition – even if processed carefully – does not satisfy the Technical Guideline or the concerning European aggregate standard or according to MSZ 4798-1:2004 Hungarian standard is not appropriate for using of normal or light-weight concrete, then it may be improved by the addition of natural aggregates by taking into consideration the data given in *Table 3*. In this case the conformance of the improved aggregate is to be proved by the compliance of the concrete, reinforced concrete and prestressed concrete properties including satisfying the

**Table 4:** Required average compressive strength of cubes with 150 mm edges

Compressive strength class of concrete $f_{ck,cyl}/f_{ck,cube}$	Value of required <i>average</i> compressive strength of cubes with 150 mm edge length, N/mm <sup>2</sup>	
	100% relative humidity curing (wet curing) $f_{cm,cube}$	Mixed curing $f_{cm,cube,H}$
Normal-weight concrete		
C8/10	14	15
C12/15	19	21
C16/20	25	27
C20/25	31	34
C25/30	37	40
C30/37	45	49
C35/45	55	60
C40/50	62	67
C45/55	69	75
Light-weight concrete		
LC8/9	13	14
LC12/13	17	19
LC16/18	22	24
LC20/22	27	29
LC25/28	33	35

durability requirements. The origin of the material production waste is known. By careful processing its quality is reliable. In this case the physical, mechanical and chemical analysis and physical classification is only necessary if the recycled aggregate would be mixed to the natural aggregate in more than 10 mass percent, or the necessity of the tests would be generated by other aspects.

## 2.2. Geometrical properties

The *particle size* of all recycled aggregate or fraction is to satisfy the geometrical requirements of MSZ 4798-1:2004 and EN 12620:2002 standards. The mixtures of the fractions are to follow the boundary curves (Fig. 4.). If the recycled aggregate is a mixture of fractions having different body densities, then the values given in mass percentages are to be understood as volumetric ones.

The grading curve of the aggregate may also be *stepped*. According to MSZ 4798-1:2004 Hungarian standard the quantity of the smaller particles, then the missing particle fractions should be present in 30-40 mass percent. The starting point of the step in case of 8 mm max. size is to be at 0.5 mm sieve, in case of 12 or 16 mm max. size at the 1 mm sieve, in case of 20, 24 and 32 mm max. size at the 2 mm sieve, while in case of 48 and 63 mm max. size at the 4 mm sieve. The end point of the step is to be at the closest standard sieve size to 0.4 *D* mm.

The grading curves may shift towards the region of the step in case of bigger fine particle portion demand. An example can be seen in Fig. 4 (broken line).

The *particle shape index* of sizes bigger than 4 mm is to be in the C8/10 – C16/20 normal-weight and in the LC8/9 – LC16/18 light-weight concrete compressive strength class is at most  $SI_{40}$  class, in the C20/25 and LC20/22 or higher classes is at least  $SI_{20}$ .

## 3. DESIGN OF RECYCLED AGGREGATE CONCRETE

The requirement against concrete mixtures made by utilising recycled aggregates is that the concrete, reinforced concrete or prestressed concrete prefabricated product or in situ concrete produced on site is to be durable. The concrete, reinforced concrete and prestressed concrete product or structure is durable, if it is able to resist the loads, stresses and environmental effects under normal service conditions and maintenance for at least 50 years of service life time safely.

The empirical compressive strength average value (cubes) of the concrete samples ( $f_{cm,cube,test}$ ) is to be higher than the  $f_{cm,cube}$  requirement value.

$$f_{cm,cube,test} \geq f_{cm,cube}$$

In Hungary mixed curing is allowed (for the first seven days under 100 % relative humidity followed by laboratory ambient conditions). In this case the form of the requirement is:

$$f_{cm,cube,test,H} \geq f_{cm,cube,H}$$

Accordingly, in Table 4 we take into consideration the difference caused by the two different types of curing by assuming that the compressive strength of test cubes cured in 100% relative humidity for 28 days (under water), are of 0.92 % of that of mixed cured (MSZ 4798-1:2004).

The concrete mix design method can be freely chosen, but the result is to be tested by laboratory tests.

Since the crushed and graded aggregates originating from demolition of structures — mainly of concrete waste — due to the variance of self strength, particle geometry, surface roughness, water absorption capability, resembles much more

Fig. 4: An example for the grading of recycled aggregate mixture in Hungary

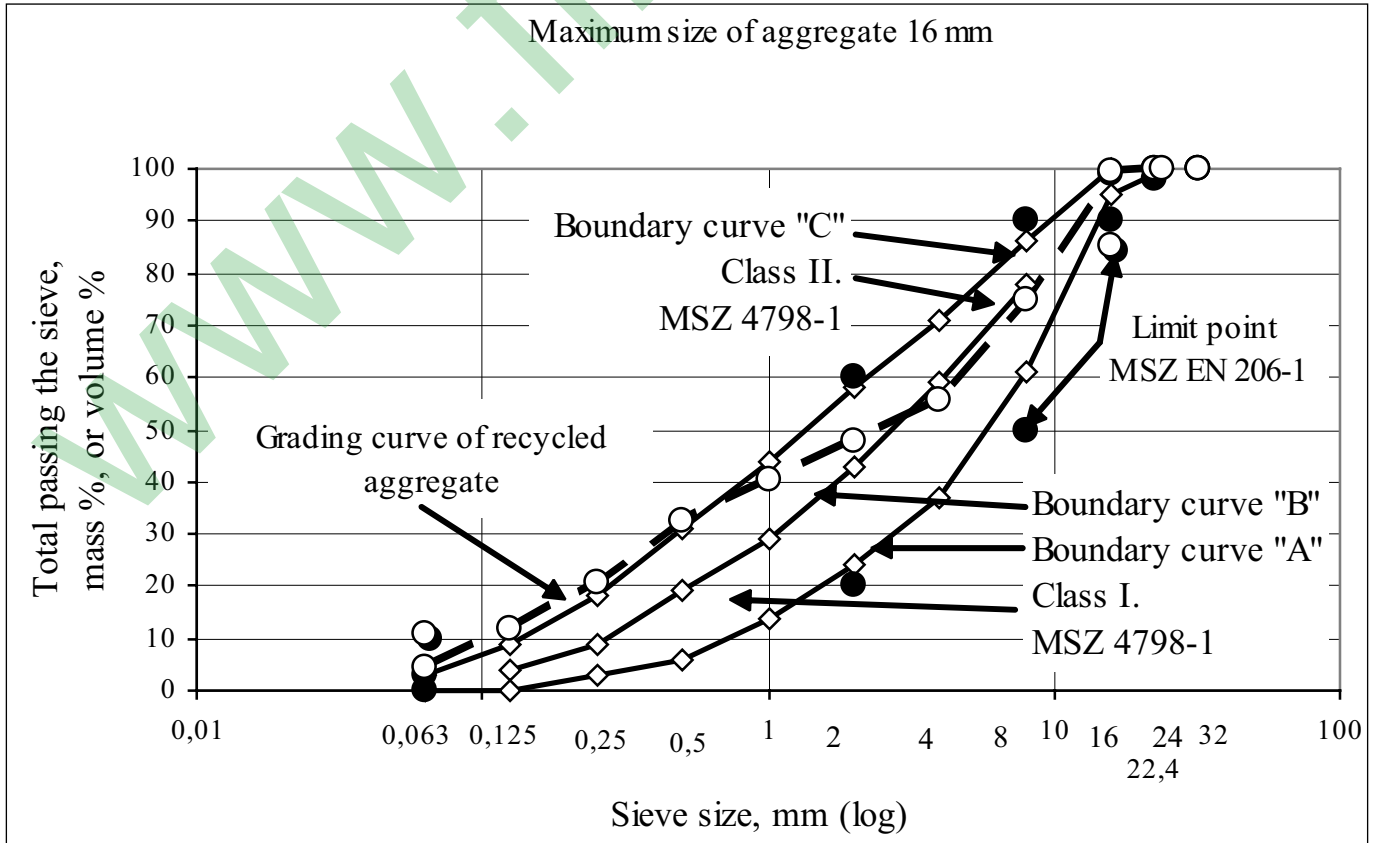

a crushed stone aggregate than a sandy gravel aggregate. Due to this reason the composition of concretes out of recycled aggregate is more appropriate to be determined by the design methods developed for crushed stone aggregates and the composition of mixed brick/concrete and brick waste aggregate concretes by the design method developed for light-weight aggregate concretes.

From technological point of view it is to be considered that the recycled mixed aggregate, especially due to the big porosity of brick waste has a high water absorption capacity. If we do not take care of this excess water demand, it will lead to the change in consistence of the designed concrete. Due to this reason the mixing water demand ( $m_v$ ) is to be calculated as the „basic water demand” ( $m_{v,0}$ ) plus the „excess water demand” ( $m_{v,d}$ ).

$$m_v = m_{v,0} + m_{v,d}$$

The „basic water demand” is a figure derived from the water/cement ratio multiplied by the cement content. The „excess water demand” may be derived from the short term water absorption capability of the aggregate (e.g. 10 minutes or if necessary by taking into consideration the workability by 1 hour).

Due to the excess mixing water dosage may increase the otherwise necessary mixing time, but it is possible to use wet premixing and pre-soaking of the light weight aggregate. Due to the strength requirements the total water dosage must be known to ensure compactability.

### 3.1. Design of normal-weight concrete using recycled aggregate made of concrete waste

If the aggregate is such a demolition or construction concrete waste, which does not fit in the physical group of *Fr-A*, then the concrete mixture is to be designed according to its physical group to a higher compressive strength class then would be the average compressive strength requirement.

The design compressive strength value of recycled aggregate concrete is obtained by multiplying the average compressive strength – belonging to the compressive strength class of concrete – (Table 4) by a multiplier  $\zeta$  which is a function of the considered physical group of the concrete waste and the compressive strength class (Table 5);

in case of wet curing:

$$f_{cm,cube,recycledconcrete} = \zeta \cdot f_{cm,cube}$$

in case of mixed curing:

$$f_{cm,cube,H,recycledconcrete} = \zeta \cdot f_{cm,cube,H}$$

We have derived the relationship to  $\zeta$  multiplier in the function of  $f_{ck,cube}$  characteristic value for the case of *Kf-D2* physical group:

$$\zeta_{D2} = 1.7343 - 0.1477 \cdot \ln(f_{ck,cube})$$

Since the regression function of the  $\zeta$  multiplier with an acceptable approximation follows the quotients of the

subsequent characteristic compressive strength class values (e.g.  $45/37=1.22$ ;  $37/30=1.23$ ;  $30/25=1.20$ ;  $25/20=1.25$ ;  $20/15=1.33$ ), so in case of the recycled aggregate in physical group *Fr-D2* we design for one higher compressive strength class than would be required.

The values of the  $\zeta$  multiplier belonging to the other physical groups may be obtained by linear interpolation between the  $\zeta$  values of the *Fr-A* and the *Fr-D2* groups (Table 5).

In Table 5 increment above 1.00 of the values of the  $\zeta$  multiplier was proportionated by the portion of the concrete waste in the aggregate according to Table 3. For example the concrete waste in *Fr-C2* physical group may only be of 70 mass percent of the aggregate used for concrete of C20/25 compressive strength class. Due to this reason the  $\zeta$  multiplier having originally the value 1.17 will take  $1+0.7 \cdot 0.17 = 1.12$  as a new value.

Another example is that, in case of a concrete of C16/20 compressive strength class the concrete waste portion in the aggregate is in *Fr-B* physical group. Then in order to achieve the  $azf_{cm,cube} = 25 \text{ N/mm}^2$  average compressive strength (Table 4) of the standard concrete cubes, which were wet cured (under water till the age of 28 days) must be designed to have a target mean strength (desired mean strength value) of  $f_{cm,cube}' = \zeta f_{cm,cube} = 1.10 \cdot 25 = 27.5 \text{ N/mm}^2$ .

It is allowed to alter from the data given in Table 5 if the experiments result in higher concrete compressive strength class then the desired one.

### 3.2. Design of light-weight concrete using recycled aggregate made of brick or mixed waste

In case of light-weight concrete, during the mix design process in addition to the strength requirements exist the demand for the body density. During the mix design procedure the initial data to be taken into consideration are the properties of the light-weight waste aggregate.

The bulk strength of light-weight aggregate is to be determined according to the 1<sup>st</sup> process in appendix A of EN 13055-1:2002 and is to be expressed by the stress belonging to 20 mm compression (Fig. 5).

Even if in the light weight aggregate concrete the mortar is the main load carrier, still it is not practical to choose its strength much higher than that of the aggregate for uniform quality and being able to utilise the strength of the aggregate.

**Fig. 5:** Example to determine the bulk compressive strength of a light-weight aggregates

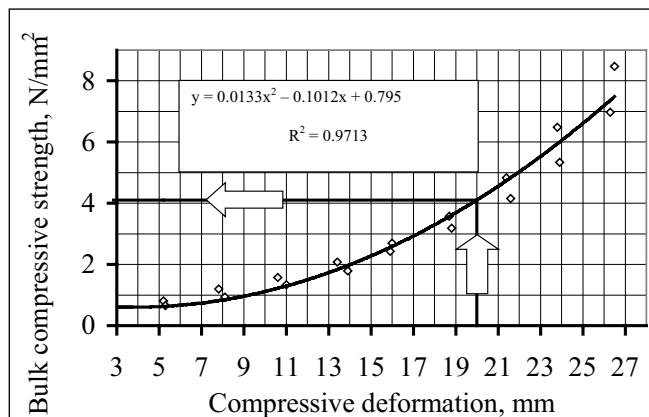

**Table 5:** Compressive strength multiplier ( $\zeta$ ) taking into consideration the physical group

Grade of concrete according to EN 206-1 standard $f_{ck,cyl}/f_{ck,cube}$	$\zeta_{0.5} = 1.7343 - 0.1477 \ln(f_{ck,cube})$	The $\zeta$ multiplier, used for the calculation of the target mean strength of concrete at the age of 28 days, which is proportionated by the concrete waste portion, in the function of the related physical group of the concrete waste, according to Table 3.						
		Fr-0	Fr-A	Fr-B	Fr-C1	Fr-C2	Fr-D1	Fr-D2
C8/10	1.39	1.00	1.00	1.13	1.19	1.26	1.32	1.39
C12/15	1.33	1.00	1.00	1.11	1.17	1.22	1.28	1+ 0.7·0.33 = 1.23
C16/20	1.29	1.00	1.00	1.10	1.15	1.19	1+ 0.7·0.24 = 1.17	1+ 0.3·0.29 = 1.09
C20/25	1.26	1.00	1.00	1.09	1.13	1+ 0.7·0.17 = 1.12	1+ 0.3·0.22 = 1.07	×
C25/30	1.23	1.00	1.00	1.08	1+ 0.7·0.12 = 1.08	1+ 0.3·0.15 = 1.05	×	×
C30/37	1.20	1.00	1.00	1+ 0.7·0.07 = 1.05	1+ 0.3·0.10 = 1.03	×	×	×
C35/45	1.17	1.00	1.00	1+ 0.3·0.06 = 1.02	×	×	×	×
C40/50	1.16	1.00	1.00	×	×	×	×	×
C45/55	1.14	1.00	×	×	×	×	×	×
C50/60	-	×	×	×	×	×	×	×

Legend: × Usage of waste from demolition, construction or material production is not recommended.

It is feasible to complement the light-weight aggregate with the fine component (generally below 1, 2, or 4 mm size) both from the point of durability and strength with natural sand. In this case the body densities of the applied aggregate types significantly differ due to what the grading curve may only be determined in volume percentages. In case of the light-weight aggregate concrete (when achieving the optimal strength) the aim is not to achieve the mortar saturated concrete state. In order to reach the load bearing capacity of light-weight aggregate concrete a minimum of 20 volume percent over-saturation of mortar is necessary. This is to be followed especially in case of an aggregate having a tabular particle shape which may easily occur in case of demolition, brick and mixed waste (Nemes, 2005).

Generally, concretes made of recycled brick or mixed waste are to be designed as light-weight concretes. During the design process the body density and self strength of the brick waste are to be taken into consideration.

The brick or mixed waste cannot be classified into any physical group. Due to this reason the target mean strength of the light-weight recycled aggregate concrete can be obtained by multiplying the calculated mean compressive strength of the appropriate strength class (Table 4) by the  $\eta_{light-weight}$  multiplier (Table 6).

In case of wet curing the samples:

$$f_{cm,cube,28,recycledconcrete} = \eta_{light-weight} f_{cm,cube}$$

In case of mixed curing the samples (first 7 days under water then at laboratory ambient conditions):

$$f_{cm,cube,H,28,recycledconcrete} = \eta_{light-weight} f_{cm,cube,H}$$

The  $\eta_{light-weight}$  multiplier is a function of the compressive strength class (Table 4) of light-weight concrete according to Table 6.

It is possible to diverge from the data given in Table 6 if the experiments result in higher light-weight concrete compressive strength class than the desired one.

## 4. DEFORMATION OF CONCRETE MADE OF RECYCLED AGGREGATES

### 4.1. Modulus of elasticity (E)

The modulus of elasticity (Young's modulus) of recycled aggregate concrete and light-weight concrete lags behind that of sandy gravel aggregate concrete.

According to the literature (Grübl – Rühl, 1998), if in the recycled concrete the quantity of the recycled particles which are bigger than 4 mm

- increases from zero (sandy gravel concrete) to 50 mass percent (recycled concrete), then the modulus of elasticity decreases by about 17.5 percent (from 34000 N/mm<sup>2</sup> to 28000 N/mm<sup>2</sup>),
- increases from zero (sandy gravel concrete) to 100 mass percent (recycled concrete), then the modulus of elasticity decreases by about 20.5 percent (from 34000 N/mm<sup>2</sup> to 27000 N/mm<sup>2</sup>),

The decrease of modulus of elasticity is also influenced by the compressive strength of the original concrete out of which the waste is originating. The waste having a lower self compressive strength reduces more the modulus of elasticity than the one having higher self compressive strength (Siebel – Kerkhoff, 1998).

**Table 6:** Strength multiplier for the calculation of target mean strength of light-weight concrete at the age of 28 days ( $\eta_{\text{light-weight}}$ )

Grade of light-weight concrete according to EN 206-1 standard $f_{ck,cyl}/f_{ck,cube}$	Values of $\eta_{\text{light-weight}}$ multiplier
LC8/9 $\rho_{LC}$ 2.0	1.50
LC12/13 $\rho_{LC}$ 2.0	1.45
LC16/18 $\rho_{LC}$ 2.0	1.40
LC20/22 $\rho_{LC}$ 2.0	1.35
LC25/28 $\rho_{LC}$ 2.0	1.30

According to *Meissner* (2000) the modulus of elasticity of recycled aggregate concrete is 10 – 40 percent lower and the deformation until failure is about 13 percent higher than that of concrete out of sandy gravel. It is reasonable to consider the modulus of elasticity of recycled concrete to a value of 20 percent lower than that of normal concrete.

According to the experiments of *Zilch* and *Roos* (2000) the modulus of elasticity of reference normal concrete, recycled aggregate of size more than 4 mm concrete and 100 percent recycled aggregate concrete is 33000 (100 percent), 26800 (81 percent) and 18200 (55 percent) N/mm<sup>2</sup>, respectively.

Recycled concrete made of *brick waste* has a significantly higher decrease of modulus of elasticity compared to normal concrete than the one out of concrete waste (*Grübl – Rühl*, 1998). If the quantity of brick waste having bigger than 4 mm particle size in the recycled concrete

- increases from zero (sandy gravel concrete) to 50 mass percent (recycled concrete), then the modulus of elasticity decreases by about 32 percent (from 34000 N/mm<sup>2</sup> to 23000 N/mm<sup>2</sup>),
- increases from zero (sandy gravel concrete) to 100 mass percent (recycled concrete), then the modulus of elasticity decreases by about 48.5 percent (from 34000 N/mm<sup>2</sup> to 17500 N/mm<sup>2</sup>).

## 4.2. Shrinkage

*Shrinkage* of recycled aggregate concrete and light-weight concrete is higher than that of sandy gravel aggregate concrete.

According to the literature (*Siebel – Kerkhoff*, 1998) the shrinkage of a concrete having 320 kg/m<sup>3</sup> cement content, 0.55 water-cement ratio, out of 100 percent recycled concrete aggregate at the age of 250 days nearly double (1.15 %) of that of the reference normal concrete (0.59 %). The modulus of elasticity of the aggregate significantly influences the shrinkage. The modulus of elasticity of concrete waste is proportional to its self compressive strength. Due to this reason it will decrease the shrinkage of recycled concrete aggregate concrete (0.90 %) if the self compressive strength of the recycled concrete aggregate increases.

According to the measurements of *Zilch* and *Roos* (2000) between the age of 7 – 50 days normal concrete dries faster than recycled concrete. Due to this reason the creep of recycled concrete in this time period is smaller than that of normal concrete, at the age of 50 days it is the same (about 0.3 %). Following this age the recycled concrete shrinks faster and at the age of 170 days the shrinkage of concrete made 100 percent from recycled aggregate is bigger by 58 percent (0.68 %) than that of normal concrete (0.43 %). If the particles smaller than 4 mm are out of sand, then the shrinkage of recycled concrete

at the age of 170 days is only by 33 percent bigger (0.57 %) than that of normal concrete.

## 4.3 Creep

*Creep* of recycled aggregate concrete and light-weight concrete is bigger than that of sandy gravel aggregate concrete.

Based on the measurements of *Siebel* and *Kerkhoff* (1998) the creep of concrete made of 100 percent recycled aggregate is 120 percent higher than that of normal concrete.

According to the experiments by *Grübl* and *Rühl* (1998) 38 days following the loading, the creep factor of concrete out of 100 percent recycled concrete aggregate is higher by 43 percent (0.97), concrete out of 100 percent recycled brick aggregate is bigger by 65 percent (1.12) than that of the reference normal concrete (0.68).

*Meissner* (2000), referring to the studies of *Grübl* and *Rühl* (1998) declares that the higher creep of recycled concrete can be deduced to the higher mortar content, the smaller modulus of elasticity and the higher water content of the demolition waste. To this is connected that, the long term strength of recycled concrete is only 80 percent of the normal concrete.

*Zilch* and *Roos* (2000) shows that while the creep factor at the age of 90 days of concrete out of recycled aggregate with particles bigger than 4 mm is 33 percent (3.6) bigger than that of the reference normal concrete (2.7), the creep factor of the 100 percent recycled aggregate concrete is already 210 percent higher (8.4). This shows that to the change of the creep factor, the character of the particles (natural or recycled) smaller than 4 mm have significant influence.

## 5. PROPERTIES OF CONCRETE BLOCKS MADE OF DEMOLITION AND MATERIAL PRODUCTION WASTE

The composition of concrete used for the production of different type concrete blocks is to be designed in such a way that the measured mean compressive strength  $f_{cm,cube,test}$  measured on standard cubes at the age of 28 days when they were wet cured and at the time of testing saturated with water should achieve  $f_{cm,cube}$  according to the corresponding strength class. In case of mixed curing, on the air dry samples the measured mean compressive strength  $f_{cm,cube,test,H}$  should achieve  $f_{cm,cube,H}$  according to the corresponding strength class at the time of testing (*Table 6*).

Out of recycled demolition and construction waste aggregate concrete usually such blocks are produced which are listed in *Table 7*. In *Table 7* the exposure class X0b(H) is for concrete with no risk of corrosion, XK1(H) stands for low level wearing risk, XK2(H) is for medium level wearing risk, XK3(H) stands for high level wearing risk, XV1(H) is for low level watertightness in Hungary.

## 6. CONCLUSIONS

During the production and the design of composition of recycled normal-weight and light weight concrete, unlike during the usual methods, also must be taken into consideration the fragmentation, bulk strength, frost resistance, water absorption and particle shape of the aggregate. The target design compressive strength of recycled concrete may be

**Table 7:** Examples for the properties of blocks made of recycled concrete

Sign of concrete according to MSZ 4798-1 Hungarian standard. Compressive strength class – exposure class – maximum size of aggregate in mm	Type of blocks made of recycled demolition or construction waste	Compressive strength class according to the statical calculation	Exposure class according to EN 206-1 and to MSZ 4798-1 Hungarian standard	Strength class according to the exposure class	Considered	
					Concrete grade	Mean strength, according to Table 4, $f_{cm,cube,H}$ N/mm <sup>2</sup>
Elements made of normal-weight concrete						
C16/20-X0b(H)-8	Hollow, slab filling element	C16/20	X0b(H)	C12/15	C16/20	27
C12/15-X0b(H)-8	Hollow, formwork element	C8/10	X0b(H)	C12/15	C12/15	21
C16/20-X0b(H)-8	Hollow, cellar walling element, max. 54 % cavity volume	C16/20	X0b(H)	C12/15	C16/20	27
C12/15-X0b(H)-16	Hollow, load bearing, internal walling element, max. 32 % cavity volume	C12/15	X0b(H)	C12/15	C12/15	21
C30/37-XF1-16	Hollow, load bearing, external walling element, max. 32 % cavity volume	C12/15	XF1	C30/37	C30/37	49
C16/20-X0b(H)-16	Core concrete of double layered footpath tile with washed surface	C16/20	X0b(H)	C12/15	C16/20	27
C35/45-XF4, XK2(H)-16	Wearing concrete of double layered footpath tile with washed surface	C25/30	XF4, XK2(H)	C35/45	C35/45	60
C35/45-XF4, XK2(H)-16	Single layered footpath tile with washed surface	C25/30	XF4, XK2(H)	C35/45	C35/45	60
C35/45-XF4, XK2(H)-16	Single layered normal footpath tile	C20/25	XF4, XK2(H)	C35/45	C35/45	60
C35/45-XF4, XK2(H)-16	Footpath tile with lawn gaps	C20/25	XF4, XK2(H)	C35/45	C35/45	60
C25/30-X0b(H)-24	Core concrete of double layered pavement tile	C25/30	X0b(H)	C12/15	C25/30	40
C40/50-XF4, XK3(H)-24	Wearing concrete of double layered pavement tile	C35/45	XF4, XK3(H)	C40/50	C40/50	67
C40/50-XF4, XK3(H)-24	Single layered pavement tile	C35/45	XF4, XK3(H)	C40/50	C40/50	67
C35/45-XF4, XK2(H)-24	Normal curb element	C16/20	XF4, XK2(H)	C35/45	C35/45	60
C40/50-XF4, XK3(H)-24	Wear resistant curb element	C30/37	XF4, XK3(H)	C40/50	C40/50	67
C30/37-XF1, XV1(H)-24	Watercourse tile	C25/30	XF1, XV1(H)	C30/37	C30/37	49
C30/37-XF1, XV1(H)-16	Watercourse covering element	C30/37	XF1, XV1(H)	C30/37	C30/37	49
C30/37-XF1, XV1(H)-16	Reinforced watercourse element, hopper element	C30/37	XF1, XV1(H)	C30/37	C30/37	49
Elements made of light-weight concrete						
LC12/13- $\rho_{LC}$ 1,8 -X0b(H)-8	Hollow, formwork element	LC12/13	X0b(H)	LC8/9	LC12/13	19
LC16/18- $\rho_{LC}$ 1,8 -X0b(H)-8	Hollow, cellar walling element, max. 54 % cavity volume	LC16/18	X0b(H)	LC8/9	LC16/18	24
LC16/18- $\rho_{LC}$ 1,8 -X0b(H)-8	Hollow, load bearing, internal walling element, max. 32 % cavity volume	LC16/18	X0b(H)	LC8/9	LC16/18	24
LC25/28- $\rho_{LC}$ 1,8 -XF1-8	Hollow, load bearing, external walling element, max. 32 % cavity volume	LC16/18	XF1	LC25/28	LC25/28	35
LC12/13- $\rho_{LC}$ 1,8 -X0b(H)-32	Dense, load bearing, internal walling element	LC12/13	X0b(H)	LC8/9	LC12/13	19
LC25/28- $\rho_{LC}$ 1,8 -XF1-32	Dense, load bearing, external walling element	LC12/13	XF1	LC25/28	LC25/28	35
LC25/28- $\rho_{LC}$ 1,8 -XF1-8	External, heat insulating walling element	LC8/9	XF1	LC25/28	LC25/28	29
LC12/13- $\rho_{LC}$ 1,8 -X0b(H)-8	Hollow, partition walling element, max. 45 % cavity volume	LC12/13	X0b(H)	LC8/9	LC12/13	19
LC25/28- $\rho_{LC}$ 1,8 -XK1(H)-16	Internal floor tile	LC20/22	XK1(H)	LC25/28	LC25/28	35

expressed in the function of the physical properties of the demolition waste aggregate.

Laboratory test results and industrial test production of concrete blocks proved that, out of concrete waste – originating from demolition – simple concrete blocks can be produced in good quality, which satisfy the density, the compressive strength and the durability requirements. Mixed waste is mainly suitable for producing light-weight concrete elements for indoor usage.

The Technical Guideline for concrete and reinforced concrete, prepared by the Hungarian group of *fib* contributes to that demolition, construction and material production waste can be recycled as concrete aggregate under controlled circumstances with good results in Hungary.

## 7. NOTATIONS

C.../...	Grades in case of normal-weight concrete
CEM...	Cement type according to the series EN 197
$d$	Minimum nominal size of aggregate, mm
$D$	Maximum nominal size of aggregate, mm
$f_{ck,cyl}$	Characteristic compressive strength of concrete determined by testing standard cylinders, after wet curing
$f_{ck,cube}$	Characteristic compressive strength of concrete determined by testing standard cubes, after wet curing
$f_{cm,test}$	Experienced mean compressive strength of concrete at the age of 28 days, measured on standard samples
$f_{cm,cube}$	Required mean compressive strength of concrete measured on standard cubes at the age of 28 days, which were wet cured, N/mm <sup>2</sup>
$f_{cm,cube,H}$	Required mean compressive strength of concrete measured on standard cubes at the age of 28 days, which were mixed (wet/dry) cured, in Hungary, N/mm <sup>2</sup>
$f_{cm,cube,recycledconcrete}$	Target design compressive strength of concrete out of recycled concrete (possibly mixed concrete/brick) waste, as the required mean compressive strength of concrete measured on standard cubes at the age of 28 days, which were wet cured, N/mm <sup>2</sup>
$f_{cm,cube,H, recycledconcrete}$	Target design compressive strength of concrete out of recycled concrete (possibly mixed concrete/brick) waste, as the required mean compressive strength of concrete measured on standard cubes at the age of 28 days, which were mixed (wet/dry) cured, in Hungary, N/mm <sup>2</sup>
$f_{cm,cube,test}$	Experienced mean compressive strength of concrete at the age of 28 days, wet cured and measured on standard cube samples, N/mm <sup>2</sup>
$f_{cm,cube,test,H}$	Experienced mean compressive strength of concrete at the age of 28 days, mixed (wet/dry) cured and measured on standard cube samples, in Hungary, N/mm <sup>2</sup>
$f_{cm,cyl}$	Required mean compressive strength of concrete measured on standard cylinders at the age of 28 days, which were wet cured, N/mm <sup>2</sup>
Fr-...	Physical group of recycled concrete and normal-weight mixed concrete/brick waste aggregates in Hungary
LC.../...	Compressive strength classes in case of light-weight concrete

$m_v$	Water dosage in 1 m <sup>3</sup> compacted fresh concrete, which is the sum of $m_{v,0}$ basic amount and the $m_{v,d}$ extra amount of mixing water, kg/m <sup>3</sup>
$m_{v,0}$	Quantity of basic mixing water dosage in 1 m <sup>3</sup> compacted fresh concrete, the value of which is the product of the designed water-cement ratio and cement dosage, kg/m <sup>3</sup>
$m_{v,d}$	Extra amount of mixing water dosage, which can be calculated from the short term water absorption capacity of the aggregate in 1 m <sup>3</sup> compacted fresh concrete, kg/m <sup>3</sup>
X0b(H)...	Exposure class for no risk of corrosion in Hungary
XF...	Exposure classes for freeze/thaw attack
XK...(H)	Exposure classes for wear resistance in Hungary
XV...(H)	Exposure classes for watertightness requirement in Hungary
$\rho_c$	Symbol of body density in Hungary
$\rho_h$	Symbol of bulk density in Hungary
$\zeta$	Multiplicator to calculate the design target mean compressive strength of recycled aggregate normal-weight concrete at the age of 28 days
$\eta_{light-weight}$	Multiplicator to calculate the design target mean compressive strength of recycled mixed and brick aggregate light-weight concrete at the age of 28 days

## 8. REFERRED STANDARDS AND TECHNICAL GUIDE

MSZ 4798-1:2004	„Concrete. Part 1: Specification, performance, production, conformity, and rules of application of MSZ EN 206-1 in Hungary”
MSZ 18288-2:1984	„Building rock materials. Test for granulometric composition and impurity. Part 2: Test of settling”
MSZ 18288-4:1984	„Building rock materials. Test for granulometric composition and impurity. Part 2: Test of chemical impurity”
EN 206-1:2000	„Concrete. Part 1: Specification, performance, production, conformity, and rules”
EN 933-1:1997	„Tests for geometrical properties of aggregates. Part 1: Determination of particle size distribution. Sieving method”
EN 933-4:1999	„Tests for geometrical properties of aggregates. Part 4: Determination of particle shape. Shape index”
EN 933-6:2001	„Tests for geometrical properties of aggregates. Part 6: Determination of particle shape. Flakiness index”
EN 1097-3:1998	„Tests for mechanical and physical properties of aggregates. Part 3: Determination of loose bulk density and voids”
EN 1097-6:2000	„Tests for mechanical and physical properties of aggregates. Part 6: Determination of particle density and water absorption”
EN 1367-1:2007	„Tests for thermal and weathering properties of aggregates. Part 1: Determination of resistance to freezing and thawing”
EN 1367-2:1999	„Tests for thermal and weathering properties of aggregates. Part 2: Magnesium sulphate test”
EN 12620:2002	„Aggregates for concrete”
EN 13043:2002	„Aggregates for bituminous mixtures and surface treatments for roads, airfields and other trafficked areas”
EN 13055-1:2002	„Lightweight aggregates. Part 1: Lightweight aggregates for concrete, mortar and grout”
EN 13139:2002	„Aggregates for mortar”
BV-MI 01:2005	„Production of concrete using demolition, construction and material production recycled waste” (in Hungarian), Hungarian Technical Guideline of concrete and reinforced concrete production, Hungarian group of <i>fib</i>

## 9. REFERENCES

- Grübl, P. – Rühl, M. (1998), „Der Einfluss von Recyclingzuschlägen aus Bauschutt auf die Frisch- und Festbetoneigenschaften und die Bewertung hinsichtlich der Eignung für Baustellen- und Transportbeton nach DIN 1045” *Technische Universität Darmstadt, Institut für Massivbau, Baustoffe, Bauphysik, Bauchemie*
- Meissner, M. (2000), „Biegetragverhalten von Stahlbetonbauteilen mit rezyklierten Zuschlägen” *Da/Stb* Heft 505. Vertrieb durch Beuth Verlag GmbH Berlin

Nemes R. (2005), „Light-weight concretes of foamed glass aggregates” (in Hungarian), PhD. thesis, *BME Department of Construction materials and engineering Geology*

Siebel, E. – Kerkhoff, B. (1998), „Eifluss von Recyclingzuschlägen aus Altbeton auf die Eigenschaften insbesondere die Dauerhaftigkeit des Betons” *Forschungsinstitut der Zementindustrie*, Düsseldorf

Zilch, K. – Roos, F. (2000), „Betonkennwerte für die Bemessung und das Verbundverhalten von Beton mit rezykliertem Zuschlag” *DafStb* Heft 507. Vertrieb durch Beuth Verlag GmbH Berlin

**Prof. György L. Balázs** (1958) PhD, Dr habil, professor in structural engineering, head of Department of Construction Materials and Engineering Geology at the Budapest University of Technology and Economics. His main fields of activities are: experimental and analytical investigations as well as modelling reinforced and prestressed concrete, fibre reinforced concrete (FRC), fibre reinforced polymers (FRP), high performance concrete (HPC), bond and cracking in concrete and durability. He is convenor of *fib* Task Groups on „Serviceability Models” and „*fib* seminar”. In addition to, he is a member of several *fib*, ACI, and RILEM Task Groups or Commissions. He is president of the Hungarian Group of *fib*. Member of *fib* Presidium.

**Prof. Tibor Kausay** (1934), M.Sc civil engineer (1961), specialization in reinforced concrete (1967), university doctor (1969), candidate of technical sciences (1978), Ph.D. (1997), associate professor of Department of Building Materials, Technical University of Budapest (1985), honorary professor at the department of Construction Materials and Engineering Geology, Budapest University of Technology and Economics (2003). Member of the Hungarian Group of *fib* (2000). Gróf Lónyay Menyhért priced Honorary member of the Szabolcs-Szatmár-Bereg county Scientific Organisation of the Hungarian Academy of Sciences (2003). Main research fields: concrete technology, stone industry. Author of about 140 publications.

**Dr. Tamás K. Simon** (1956), M.Sc civil engineer (1983), PhD (2005). Between 1983 and 1990 consultant of VIZITERV Consulting Engineering Company for Water Engineering. For two years, between 1990 and 92 developing and constructing engineer of „kas” Insulation-techniques Developing and Constructing Incorporated Company. Since 1992 senior lecturer of Budapest University of Technology and Economics, Department of Construction Materials and Engineering Geology. Between 2005 and 2006 lecturer at Ybl Miklós College of Technology, Department of Building Materials and Quality Control. His main fields of interest: concrete and reinforced concrete structures, rehabilitation of structures, concrete technology, quality control. Member of the Hungarian Chamber of Engineers and the Hungarian Group of *fib*.



# CHARACTERISTICS OF TUNNEL FIRES



Sándor Fehérvári

During the last decades, an increasing number of incidents in road and railway tunnels have attracted the attention of the public to the danger of tunnel fires. These incidents established that, besides the development of life threatening smoke, the development of heat is also of cardinal importance and its effect on the structure should also be further investigated. In Hungary the importance of researches of characteristics of tunnel fires are increased through the building of metro line 4 and the design of new tunnels of M6 and M0 highways. This paper focuses on the peculiarities of fires that ignite in closed spaces and the accumulation, as well as the distribution, of heat during the fire.

**Key words:** tunnel, fire, fire load, fire characteristic

## 1. INTRODUCTION

One of the bases of the existence of our modern industrial community is the provision of reliable, safe and fast traffic infrastructure, as well as safe and efficient public transport in cities.

The traffic load of international railway and road networks has increased tremendously during the last decades, especially with regards to the number of freight trains and heavy trucks. Transport efficiency has been improved by the construction of high-speed railway lines and the development of highway networks. As a consequence of standard designs of the longitudinal sections, it has been necessary to construct tunnels and tunnel networks in mountainous areas.

Observations make it clear, that the increasing traffic requirement in cities can be possibly best fulfilled by improving or constructing underground traffic networks.

## 2. TUNNEL FIRES

By forcing traffic – railway, road or public transport – into tunnels, i.e. into closed spaces, the requisite safety requirements increase considerably for both the requirements for the protection of human life and the protection of the structures. In the case of abnormal operating conditions, the most dangerous situation either to human life or the tunnel structure, is fire.

Despite growing and rigorous safety directives, the number of the accidents and the damage in tunnels all around the world shows a growing tendency. The reasons for this increment are:

- *increase in traffic load*, with an increasing percentage of trailer trucks
  - *increasing speed*, producing an increase in kinematic energy of the colliding masses in the case of an accident.
- This statement is an essential element of the safety design



of tunnels of new high-speed railway networks presently under construction.

- *increasing length of tunnels*, as a facility of advancing construction technologies as well as the demands of the public, the economy and the environment.
- *increasing possibility of terrorist attack*, especially in the case of tunnels in cities with underground networks which have become the target of terrorist attacks in the last decades.

Between 2000 and 2004 40 serious tunnel fire incidents were recorded, including the most serious cases as listed below:

(Fig. 1, Beard and Carvel, 2005). 6 of them with fatalities (Rotsethorn, Norway, 29. 07. 2000; Kitzsteinhorn, Austria, 11. 11. 2000; Gleinalm, Austria, 07. 08. 2001; St. Gotthard, Switzerland, 24. 10. 2001; Jungangno, South-Korea, 12. 02. 2003; Fløyfjell, Norway, 10. 11. 2003). Also about 30 people were killed in 1999 in the accident at the Mont Blanc tunnel.

However, statistical analysis demonstrates that traffic in tunnels is relatively safer than open road traffic (Beard and Carvel, 2005). The principle reasons for this are the due to the installation of early information systems, smoke and fire detectors, automatic warning and fire-systems, the construction of emergency escape-routes. Nevertheless there are essential differences between the consequences of accidents in closed or in open spaces. In closed spaces, fire is more threatening because of the close proximity of persons and the effects on materials of the load bearing structural elements (Fig. 2-5).

The investigation of the structural behaviour of materials under direct fire load plays an important role in international research. The behaviour of the material in the load bearing structural element, as well as the behaviour of the structural element itself, separately or together, has been the focus of numerous research programmes. However the behaviour of the material does not depend on the type of structure alone. The combined behaviour in a tunnel cannot be compared to that in a high building in the case of a fire. The first difference is the variation in flammable materials and secondly the barriers which block the ventilation and spread of fire as well as the consequent accumulation of heat. Accumulation of heat is very dangerous in closed tunnels. The thick cross-sections of the structures and the surrounding rock or soil are extremely slow in dissipating the evolved heat. Therefore, the possibility of high gas temperatures developing quickly in the area of the fire is high.

### 3. FIRE LOAD

It is necessary to define the character of the fire and the heat loading to the material when investigating the structural materials. Furthermore the distribution of the heat versus time and space should also be known.

The heat mass dissipated from a single vehicle can be determined with a reasonable degree of certainty. Fig. 6 shows the equivalent heat load (Putz, 2005) and average heat mass evolved due to the total burn out of different kinds of vehicles.

The exact mass of the evolved heat can be calculated for each kind of vehicle if the individual components are known. However, this calculation is only applicable for underground networks where the same kind of vehicle has been tested. For example: by a total burn out of a type NF 10 underground railway wagon (as applied in Dusseldorf, length 40 m, width 2.4 m) the evolved heat mass generates 91 592 854 kJ energy

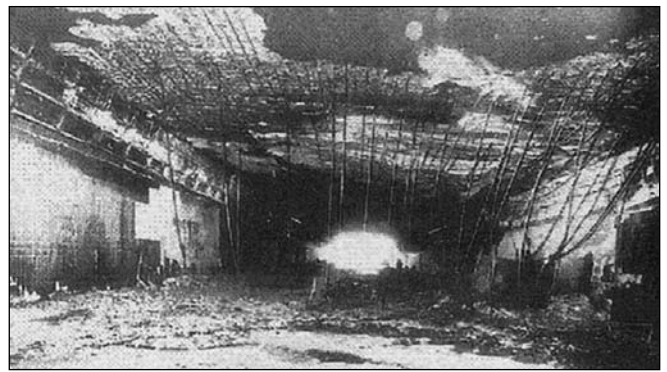

Fig. 2: Damage in the Highway Tunnel, Hamburg (1968) (Haack, 2002)



Fig. 3: Damage in the Channel Tunnel (18. 11. 1996) (Haack, 2002)



Fig. 4: Damage in the Mont Blanc Tunnel (24. 03. 1999) (Haack, 2002)



Fig. 5: Fire in the St. Gotthard Tunnel (24. 10. 2001) (Schlüter, 2004)

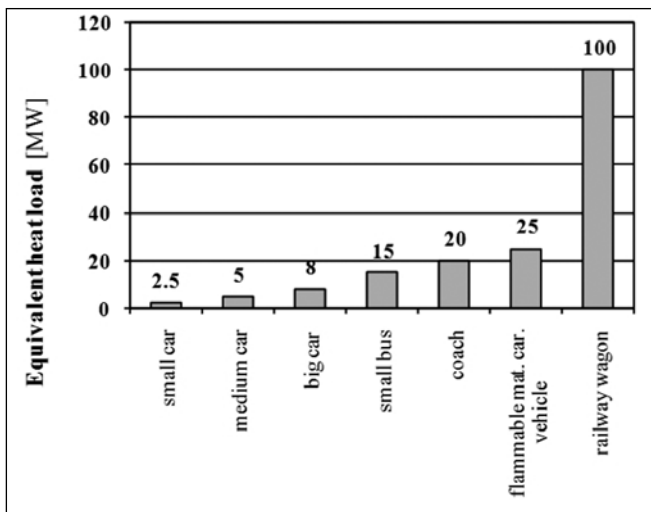

Fig. 6: Equivalent heat load for different kinds of vehicles (Putz, 2005)

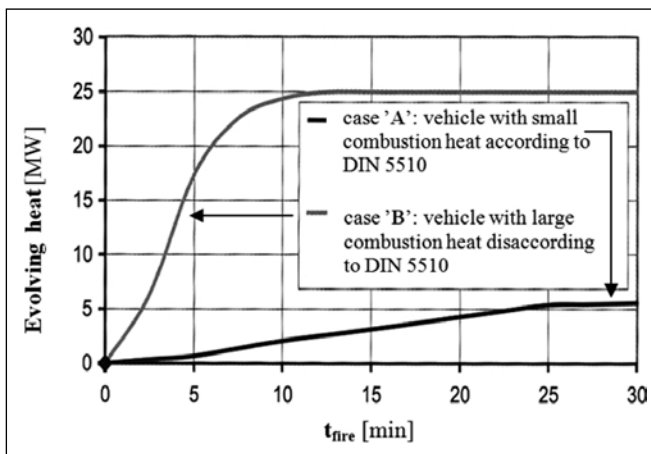

Fig. 7: Vehicles of small and large combustion heat (Blennemann and Girnau, 2005)

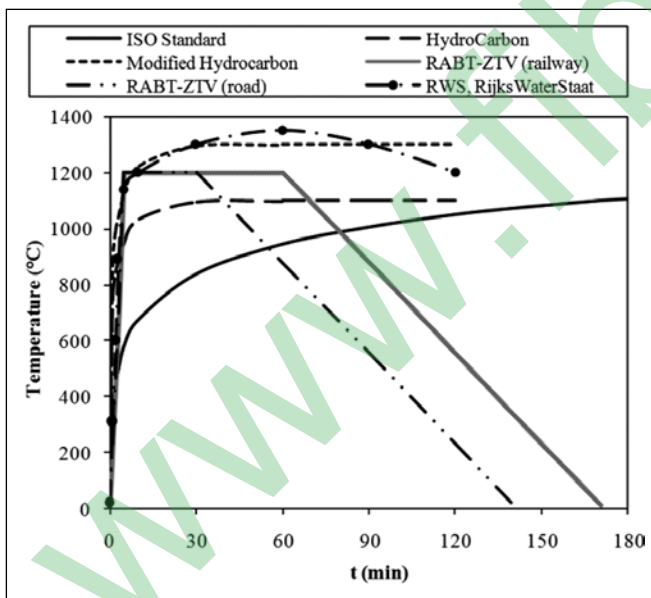

Fig. 8: Standardized fire-characteristic curves; air/gas temperatures around the fire (after Blennemann and Girnau, 2005)

(Blennemann and Girnau, 2005). However, this evolving energy is distributed in time and space. Thereby the total energy mass is definable for every kind of vehicle if the components can be summated.

It is important to note that real fire protection begins with the applied materials of the vehicles. The total mass of the flammable materials in a vehicle design conforming to modern standards and considerations is smaller, so the evolving of heat and (toxic) smoke puts less strain on the human organism and

the structure. Fig. 7 shows that the heat-time distribution is also more advantageous.

When designing tunnels, there is no opportunity (with some rare exceptions) to calculate and analyse the individual heat evolving. Instead of describing of fires in terms of a “correct” standard fire, characteristic curves were established to describe the characteristic of an average tunnel fire. The common used fire-characteristic curves are shown on the Fig. 8.

Each curve is based on one or more of the following: various research, suppositions, national standards, flammable material compositions and the results of small or large scale tests (Promat, 2006).

*ISO Standard:* The characteristic curve used mostly in the design of buildings, which is defined by many European National Standards (ISO 834, BS 476:part 20, DIN 4102, AS 1530). It is based on the continuous ignition and natural burning of flammable materials surrounding the fire. The equation of the curve is shown in (1).

$$T [^{\circ}\text{C}] = 20 + 345 \cdot \log(8 \cdot t [\text{min}] + 1) \quad (1)$$

The maximum temperature can be calculated on the basis of the fire load time defined by the National Standards. The maximum evolving heat mass is around 30 MW. It is not proposed that the ISO standard “ISO” curve be used in the design of tunnels. Fig. 8 shows that the standard “ISO” curve has a relatively long heat accumulation time which is not acceptable to describe the tunnel fire theory of fast heat accumulation.

*HydroCarbon:* Hydrocarbon fires demonstrate an alternate characteristic behaviour. Both the characteristic behaviour and the extreme of the curve differ from the commonly used standard “ISO” curve. The faster ignition of the hydrocarbons causes a faster increase and larger combustion fires produce higher maximum temperatures. The equation of the curve is shown in (2).

$$T [^{\circ}\text{C}] = 20 + 1080 \cdot (1 - 0,325 \cdot e^{-0,167 \cdot t [\text{min}]} - 0,675 \cdot e^{-2,5 \cdot t [\text{min}]}) \quad (2)$$

*HydroCarbon Modified:* Analogue to the “HydroCarbon” fire, the French Standard defines a fire characteristic curve with a maximum temperature of 1300 °C as opposed to the 1100 °C shown above. The equation of the curve is shown in (3).

$$T [^{\circ}\text{C}] = 20 + 1280 \cdot (1 - 0,325 \cdot e^{-0,167 \cdot t [\text{min}]} - 0,675 \cdot e^{-2,5 \cdot t [\text{min}]}) \quad (3)$$

Both the “HydroCarbon” and the “HydroCarbon Modified” fire characteristic curves came from the petrol chemical industry into civil engineering. Their use could be demonstrated because of the huge amounts of benzene and gasoline around the fire, especially in road tunnels.

*RABT-ZTV:* The “RABT-ZTV” fire characteristic curves have been determined and standardized in Germany as a result of large scale tests. In contrast with the foregoing theories, the curves are described with break points instead of equations. Different characteristic curves were determined for both railway and road tunnels. Both curves rapidly reach the maximum temperature (1200 °C) within 5 minutes. The maximum temperature is then held for 25 to 55 minutes depending on the type of curve. The cooling phase is 110 minutes for both curves (Table 1).

The German fire characteristic curves are used for design as well as for research because of the linear drive. Curves well define the rapid increase of the temperature in the first

**Table 1:** Significant break points of the "RABT-ZTV" curves (Promat, 2006)

RABT-ZTV (railway)	
t (min)	T (°C)
0	15
5	1200
60	1200
170	15
RABT-ZTV (road)	
t (min)	T (°C)
0	15
5	1200
30	1200
140	15

**Table 2:** Significant point of the RWS, Rijkswaterstaat fire characteristic curve (Promat, 2006)

t (min)	T (°C)
0	20
3	890
5	1140
10	1200
30	1300
60	1350
90	1300
120	1200

few minutes (Fig. 9). However, this is the only characteristic which determines the parameters of the cooling phases. The speed of the cooling is also important, not only for the model, but also for the residual properties of the material.

*RWS, Rijkswaterstaat:* Characteristic curves from the Netherlands determined at 1979. This curve shows the highest maximum temperature of all the curves above. It describes the worst case scenario on an accident in a road tunnel when a tanker with 50 m<sup>3</sup> gasoline explodes. As a consequence of the accident, 300 MJ of energy evolves in 180 minutes. The behaviour of the curve shows rapid increasing during the ignition period, deceleration in rate of temperature increase in the second period, a significant maximum point, slight recession and stagnation (Table 2)

Apart from the lack of the cooling phase (the flammable material is burn out after 180 minutes) the RWS fire characteristic curve has the greatest upper bound of almost 100% of the tunnel fires.

The curves above represent the distribution the maximum design value of air or gas temperature in a tunnel versus time.

The spatial changes of temperature were also examined. It was verified that the maximum temperature develops at the roof of the tunnel; lower temperatures are noticeable at the walls. Figs. 10-12 shows the distribution of developed air temperatures during the fire flaming out from different kind of vehicles.

The longitudinal distribution also shows the spatial changes extending away from the fire. However by the time of ignition, the secondary ignition of flammable materials around the fire is also possible. Thereafter the maximum points of the temperature curve are extended over the tunnel's longitudinal



**Fig. 9:** Large scale test in Germany (1998) (Haack, 2002)

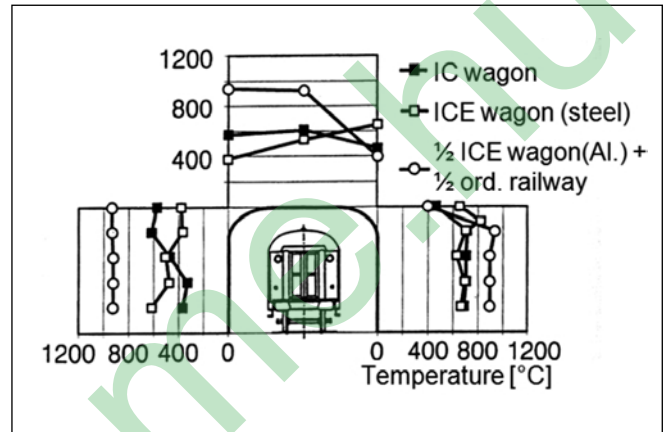

**Fig. 10:** Maximum air temperatures in the walls during a railway tunnel fire (Richter, 1993)

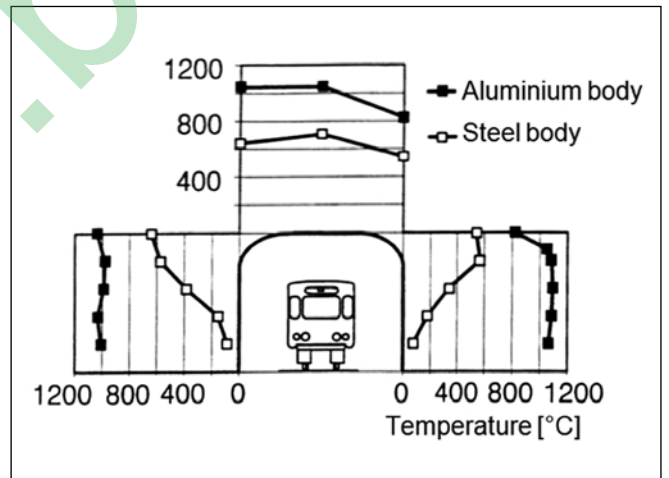

**Fig. 11:** Maximum air temperatures in the walls during an underground railway tunnel fire (Richter, 1993)

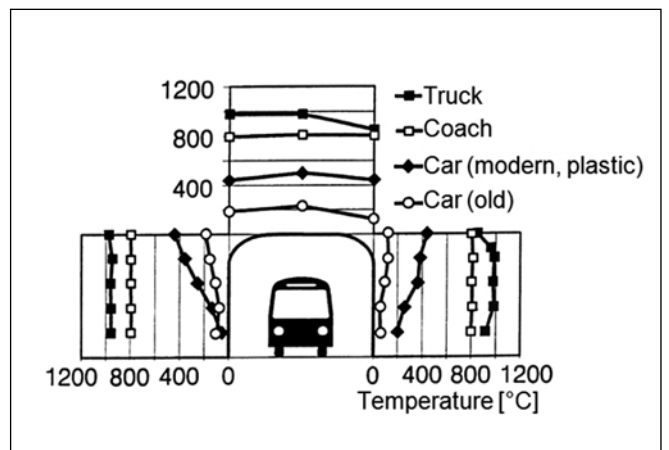

**Fig. 12:** Maximum air temperatures in the walls during a road tunnel fire (Richter, 1993)

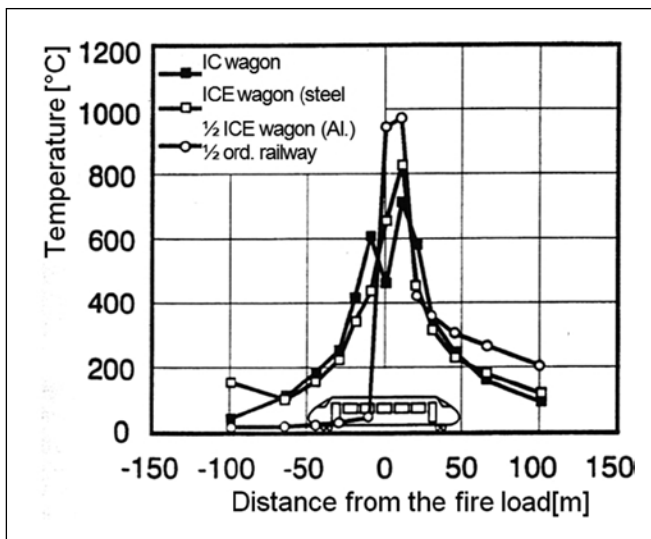

**Fig. 13:** Distribution of air temperature parallel to the longitudinal axis, away from the fire (Richter, 1993)

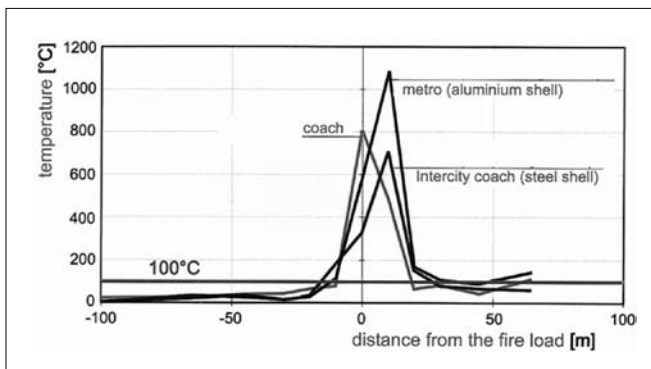

**Fig. 14:** Distribution of air temperature parallel to the longitudinal axis, away from the fire (Blennemann és Girmau, 2005)

section, and increasingly more tunnel linings will be subjected to the maximum thermal load as shown on *Figs. 13-14*.

## 4. CONCLUSIONS

During a tunnel fire, a huge amount of heat is evolved. Developing heat can only dissipate slowly due to the form of the structure and the surrounding soil and rock. Therefore significant values of air temperature can be formed at the place of fire in the structure.

International research provides valuable information about the evolving heat mass based on the theoretical assumptions in small or large scale tests. Special fire characteristic curves were drawn up by West European practices which calculate faster heat accumulation and higher maximum temperature value than the “conventional” characteristics that are valid in

the actual countries. Thereby the special curves are advisable for the numerical modelling of the effect of fire heat on the wall, as well as for research propose into the structural materials and the structure itself.

This paper demonstrates that the air temperature around the place of the fire shows a distribution in the cross section as well as in the longitudinal section of the tunnel. Thereby the temperature values for the load of the structure are definable.

It can be stated that by designing a new tunnel, from which a burning vehicle cannot escape, the consequences of the heat evolving should be examined. In older tunnels, where heat resistant of structure was not observed, the same considerations should be performed and the structure should be equipped with additional fire protection.

Thence in Hungary it is necessary to determine our standards for the characterization of tunnel fires. Thereunto researches (full scale test and small models, numerical analysis) are to be carried out beside the acceptance of European regulations and standards.

## 5. ACKNOWLEDGEMENTS

Author wish to express his gratitude to Mr. Martin Smith and Mr. György Posgay for their advices and proof reading of the present paper.

## 6. REFERENCES

- Beard, A. and Carvel, R. (eds.) (2005): „The Handbook of Tunnel Fire Safety”, *Thomas Telford Ltd.*, London
- Blennemann, F. and Girmau, G. (eds.) (2005): „Brandschutz in Fahrzeugen und Tunneln des ÖPNV”, *Alba Fachverlag*, Düsseldorf
- Haack, A. (2002): „Current Safety Issues in Traffic Tunnels”, *STUVA*, Köln
- Promat (2006): „Fire Curves”, [www.promat-tunnel.com](http://www.promat-tunnel.com)
- Putz, U. (2005): „Brandbeanspruchung von Tunnelbeton“, 45. Forschungskolloquium des DAFStb, 100. Jahrgang, *Beton- und Stahlbetonbau*, pp. 173-176.
- Richter, E. (1993): „Heißgasentwicklung bei Tunnelbränden mit Straßen- und Schienenfahrzeugen – Vergleich gemessener und in Vorschriften enthaltener Temperatur-Zeit-Verläufe“, *STUVA Tagung '93 in Hamburg*, *STUVA*, Köln, pp. 131-137.
- Schlüter, A. (2004): „Baulicher Brandschutz für Tunnelbauwerke: Richtlinien, Vorgaben, die Realität und geeignete Maßnahmen“, *Tunnel*, November 2004 (Sonderdruck: Promat GmbH.)
- DIN 5510-2 (2003. 09.): Vorbeugender Brandschutz in Schienenfahrzeugen - Teil 2: Brennverhalten und Brandnebenerscheinungen von Werkstoffen und Bauteilen; Klassifizierungen, Anforderungen und Prüfverfahren

**Sándor Fehérvári** (1981), MSc. in civil engineering (BME 2006). PhD student at BME, Dep. of Construction Materials and Engineering Geology. Main fields of interest are the effect of the tunnel fires on structures, structural and curtain grouting, building and repair techniques of underground and tunnel structures. Member of the Hung. Group of *fib*, the Hung. Chamber of Engineers, the Hung. Tunnelling Assoc., the Hung. Sci. Assoc. for Transport, the Sci. Society of Silicate Industry (Concrete Div.). Activities: ITA WG 6 (Maintenance and Repair).

# EXPERIMENTAL STRENGTH ANALYSIS OF CFRP STRIPS



György L. Balázs – Zsombor K. Szabó

Use of fibre reinforced polymer (FRP) materials for structural strengthening is an advanced technique. FRP materials are able to transfer considerably high tensile stresses. These materials can be designed having various mechanical properties and cross sections, therefore nowadays various types of FRP reinforcements are available.

A recently developed testing device for tensile loading of FRP strips will be presented herein. Two materials of the same producer were loaded up to failure using this device. Material properties such as tensile strength, modulus of elasticity and ultimate strain of the tested materials were experimentally determined.

**Keywords:** FRP strips, gripping device, tensile testing

## 1. INTRODUCTION

Use of fibre reinforced polymer (FRP) materials for structural strengthening is an advanced technique. The principal reasons for strengthening are deterioration of reinforced concrete structures (through electrolytic corrosion) and changed serviceability demands. High tensile strength to weight ratio and corrosion resistance of fibre reinforced polymers (FRPs) make them attractive for various strengthening applications. FRP can be easily applied and is able to carry tensile forces of reinforced concrete structural elements.

Fibre reinforced polymers can be used in form of pultruded strengthening elements or in form of woven fabrics. Pultrusion as defined in *fib* Bulletin 14 (2001) is an automated, continuous process for manufacturing composite rods and structural shapes having a constant cross section: roving and tows are saturated with resin and continuously pulled through a heated die, where the part is formed and cured.

Usually, the fibres are oriented in one main direction in pultruded elements and are bonded together by the resin matrix for proper force transfer. Based on the used fibres we can distinguish three basic types of FRP, carbon (CFRP), aramid (AFRP) and glass (GFRP).

High tensile strength of pultruded FRP elements is explained by strong orientation of the used high strength fibres. Measuring the tensile capacity of FRP materials is a difficult task. The FRP elements loaded in tension can fail due to the stress concentration at the gripping device. Therefore, the testing device can limit or cause large scatter of the test results (Malvar, Bish, 1995; Benmokrane, Zhang, Chennouf, 2000).

The gripping device presented herein was developed for tensile testing of pultruded FRP strips in order to enable load application up to the tensile capacity.

## 2. GRIPPING DEVICE

The appropriate application of tensile load on the FRP strip is very difficult. This difficulty comes from the high tensile strength of FRP parallel with the fibres, in comparison to the relatively low strength perpendicular to the fibres. Due to the sensitivity of fibres a special gripping device (*Fig. 1*) is

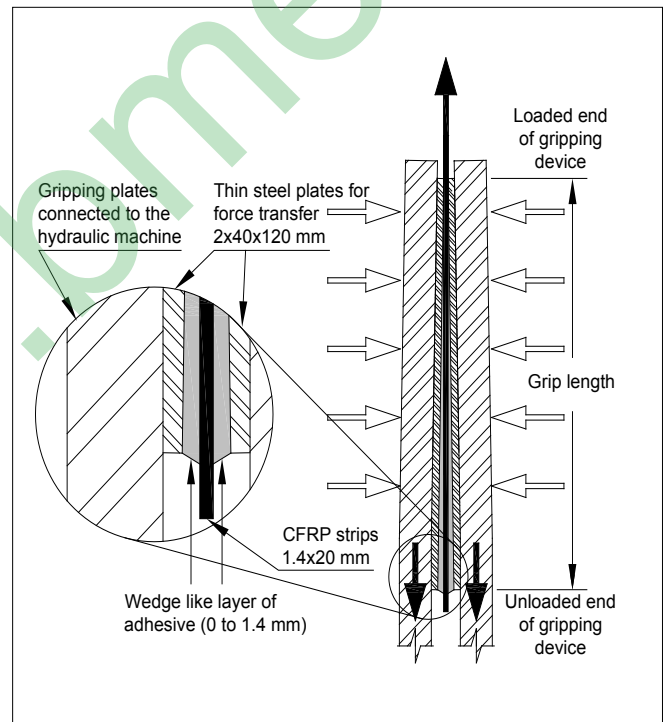

**Fig. 1:** Gripping device developed for tensile tests of pultruded FRP strips

needed to be developed to avoid local failure of FRP. Thin steel plates were glued for proper force transfer on the ends of the FRP. The adhesive thickness gradually increased (from 0 up to 1.4 mm) from the loaded to the unloaded end of the gripping device on the whole grip length. The resulted wedge like shape (glued end connection) enabled proper gripping of the FRP strip between gripping steel plates held together by steel screws. The gradually increasing adhesive thickness enabled proper stress distribution along the strips within the grip length. In this way it was possible to apply loads up to the tensile failure load of FRP strip. The gripping device was connected to the testing machine with a hinge enabling free rotation parallel with the plane of FRP strip.

The gripping device is in accordance with the principles of ASTM (2000). Due to its simplicity it can be used in various test machines.

## 3. EXPERIMENTAL INVESTIGATION

### 3.1. Test material

The experimental strength analysis was performed on two carbon FRP strips from MAPEI Hungary Ltd. with different moduli of elasticity. The strips of 1.4 mm nominal thickness had roughened surface. Material properties according to the supplier's data sheet are presented in *Table 1*.

**Table 1:** Material properties according to the supplier

Material properties	Carboplate E170	Carboplate E250
Tensile strength, N/mm <sup>2</sup>	≥3100	2500
Modulus of elasticity, GPa	170	250
Ultimate strain, %	2.0	0.9
Fibre content, Vol %	68	65

### 3.2. Preparation of specimens

Specimens were produced by splitting the 50 mm wide original strips into two, equal strips with 500 mm length. Special care was given to the longitudinal alignment of fibres. Specimen width was measured on three locations with an electronic digital calliper, and it was properly taken into consideration.

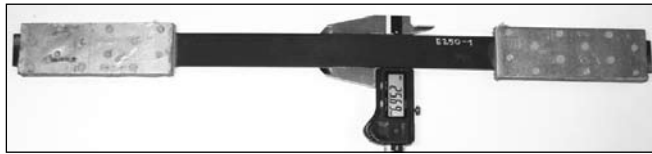

**Fig. 1:** Gripping device developed for tensile tests of pultruded FRP strips

The FRP strip ends were prepared as follows:

- the strips were cut to size, width was measured,
- strips surfaces were cleaned,
- two thin (thickness of 2 mm) steel plates for force transfer (40 mm wide and 120 mm long) were glued to the FRP strips (*Fig. 2*), so glued gripping end connections were prepared (see details in chapter 2),
- strain gauges were glued to the prepared FRP surface with central alignment,
- the thin plates for force transfer were mounted between two thick steel plates for gripping with central alignment,
- the thick gripping plates were held together with screws, as a result the end connection of the FRP worked as a wedge,
- the thick gripping plates were connected to the testing machine and the tensile load was applied.

### 3.3. Loading and test data acquisition

INSTRON (model 1197) hydraulic test machine was used for loading (*Fig. 3*). Test machine is equipped with a movable and a stationary head and a load cell. Tests were carried out in displacement control. The strain rate was selected to produce failure within 1 to 10 min. according to ASTM (2000). A displacement rate of the machine head of 2 mm/min. was chosen.

The ends of the tested strips were attached to the loading machine using the recently developed gripping device. The strength of the materials was determined from the maximum load recorded. The stress-strain response of the material was monitored with KMT-LIAS-06-1.5/350-6 strain gauges (resistance of 350 Ω; active gauge length 1.5 mm). Tensile modulus

of elasticity and ultimate strain was determined. Applied load and readings of the strain gauges were recorded by real time data acquisition with sampling rate of 5 Hz.



**Fig. 3:** Test arrangement

Centric loading of the strips was very important to reduce premature failure and scatter of test results. In order to reduce load eccentricities, the gripping devices at both ends of the strips were connected with hinges to the test machine. Specimen and gripping alignment were carefully checked.

## 4. EXPERIMENTAL RESULTS

### 4.1. Evaluation of experimental results

Material properties of fibre reinforced materials are mostly influenced by the fibres. Fibre content ( $V_f$ ) of the composite is often given by the material supplier and indicates in volume percentage the amount of fibre contained in the composite. For the tested materials the fibre content was 68 % for E 170 and 65 % for E 250, respectively.

Tensile strength and the modulus of elasticity for a composite can be given in various forms. Using Eq. (1) (rule of mixtures) the material properties of the composite, for example the modulus of elasticity ( $E_f$ ) can be calculated as sum of the fibre modulus of elasticity ( $E_{fib}$ ) and matrix modulus of elasticity ( $E_m$ ) each multiplied by their content percentage (CNR-DT 200, 2004).

$$E_f = V_{fib} \cdot E_{fib} + (1 - V_{fib}) \cdot E_m \quad (1)$$

Common inconsistency of data sheets is that usually they do not always specify the statistical level of material properties. It is also often missing from data sheets if the properties are related to the whole composite (strip) section or only to the fibres. In our tables material properties for the composites are given.

Modulus of elasticity was calculated by Eq. (2):

$$E_f = \frac{\Delta\sigma_f}{\Delta\varepsilon_f} \quad (2)$$

Values were taken by every 10 seconds within the 10 to 50% tensile strength range.

$\Delta\sigma_f$  and  $\Delta\varepsilon_f$  are representing differences in tensile stress and strain in 10 seconds. Their average values are given in *Table 2* for the E170 strips and *Table 3* for E 250 strips. The

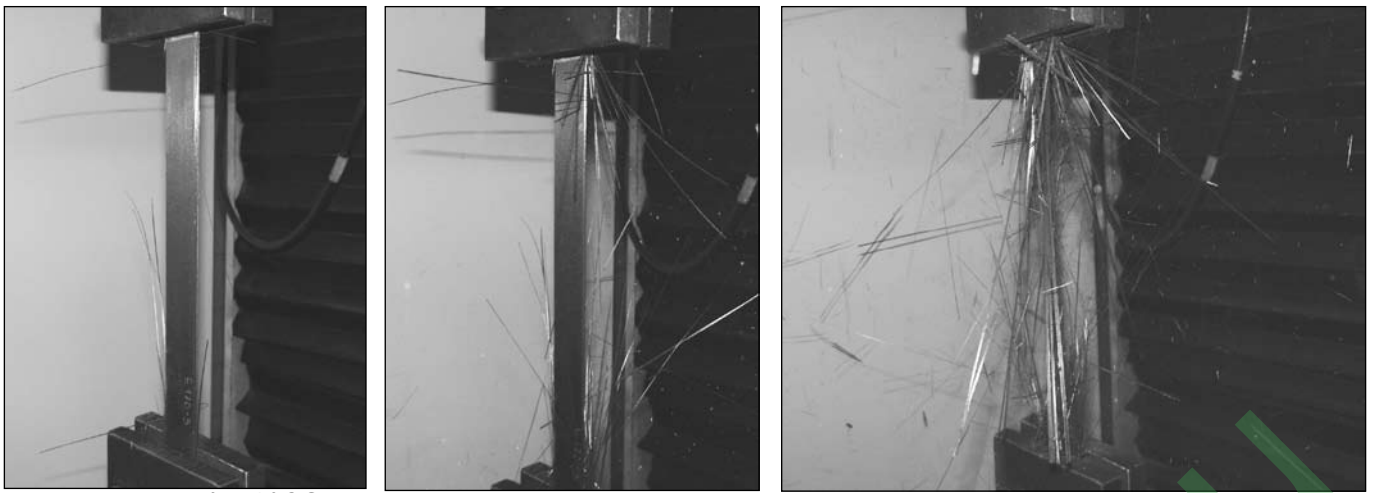

Fig. 4: Failure process for E170-3 CFRP strip

Table 2: Measured material properties for E170 strips

Specimen	Average strip cross-section mm <sup>2</sup>	Ultimate load kN	Tensile strength of strip N/mm <sup>2</sup>	Ultimate strain of strip %	Modulus of elasticity N/mm <sup>2</sup>
E170-1	35.52	111.2	3131	2.04	171 900
E170-2	36.26	104.4	2879	1.98	163 700
E170-3	37.24	125.6	3373	-	-
E170-4	33.64	108.3	3219	2.02	167 800
E170-5	34.47	107.1	3108	2.12	156 200
E170-6	33.32	107.4	3223	-	-
E170-7	36.12	113.9	3153	-	-
Average			3155	2.04	164 900
Stand. deviation			150	0.06	670

Table 3: Measured material properties for E250 strips

Specimen	Average strip cross-section mm <sup>2</sup>	Ultimate load kN	Tensile strength of strip N/mm <sup>2</sup>	Ultimate strain of strip %	Modulus of elasticity N/mm <sup>2</sup>
E250-1	35.52	111.1	3128	1.16	273 800
E250-2	36.26	112.5	3103	1.15	272 100
E250-3	35.73	103.0	2883	NA	257 100
E250-4	33.64	99.1	2946	1.12	252 100
E250-5	35.85	97.9	2731	1.06	265 700
Average			2958	1.12	264 200
Stand. deviation			164	0.045	940

representative strain ( $\epsilon_p$ ) was calculated in case of three strain gauges using Eq. (3) and in case of two strain gauges using Eq. (4).

$$\epsilon_f = \frac{(\epsilon_1 + \epsilon_3)}{2} + \epsilon_2 \quad (3)$$

$$\epsilon_f = \frac{(\epsilon_1 + \epsilon_2)}{2} \quad (4)$$

## 4.2. Discussion

Figs. 4 to 5 and Table 2 summarize the failure process and the measured material properties of E170 CFRP strips.

Failure of the lower elastic modulus specimens (E170) can be characterised according to ASTM (2000) as an XGM failure (Fig. 4 and cover page photo): failure type was explosive (X), gauge (G) area was the failure area with a middle (M) failure location. The explosive failure indicates a proper distribution

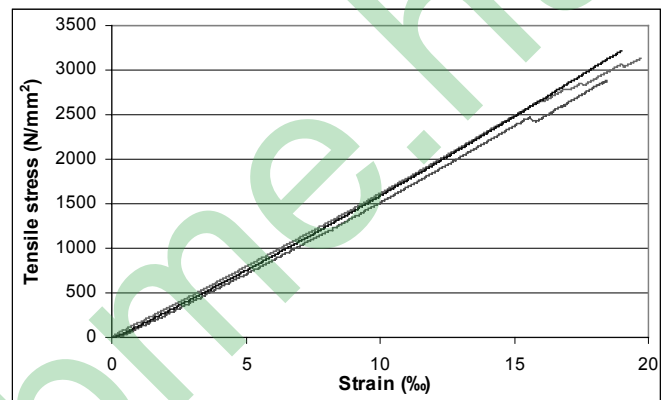

Fig 5: Measured tensile stress-strain diagram for E170 CFRP strips

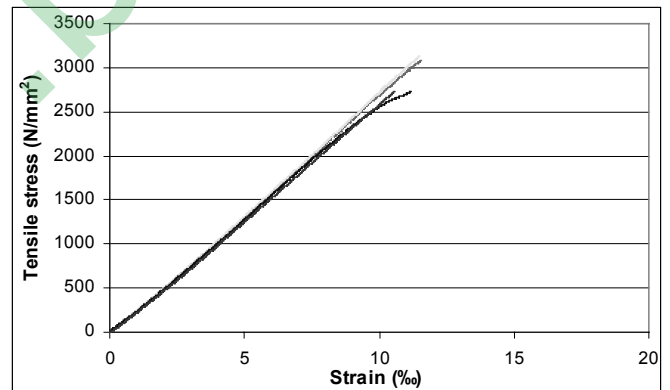

Fig 6: Measured tensile stress-strain diagram for E250 CFRP strips



Fig. 7: Post failure picture of 250-4 specimen

of stresses in the loaded strip. Failure at the grip was avoided at each of the tested specimens showing effectiveness of the developed gripping device.

Stress-strain relationship was linear elastic (Fig. 5). Fibres at the sides of the strip started to fail only close to the maximum load. Local failure of fibres produced slight strain increase compared to the linear increase. Local fibre failure close to the peak load gradually reduced the effective cross-section of the strip. Tensile strength of the material was calculated with the initial cross-section. Therefore, the calculated tensile strength can be considered as a lower limit value. Avoiding the



local failure would result in increased tensile strength values for the tested material. *Table 2* summarizes ultimate loads, tensile strengths, ultimate strains and moduli of elasticity of E170 strips:

According to our measurements (average of 4 to 5 values)

tensile strength:	3155 N/mm <sup>2</sup>
ultimate strain:	2.04 %
modulus of elasticity:	164 900 N/mm <sup>2</sup>

In case of E250 strips the stress-strain relationship was linear elastic up to failure (*Fig. 6*). Almost no decrease in the tensile load was observed prior to failure while in case of the E170 strips a decrease in the measured tensile load was observed from 5 to 15 sec. before failure.

For the higher modulus E250 material a different failure was recorded. Less intensive tendency to local fibre failure was observed for this material. Transverse rupture of fibres was observed close to the gripping. According to ASTM (2000) the failure could be hardly categorized. The observed failure type was explosive, with longitudinal splitting of the strips as shown in *Fig. 7*.

*Table 3* summarizes ultimate loads, tensile strengths, ultimate strains and moduli of elasticity of E170 strips:

According to our measurements (average of 4 to 7 values)

tensile strength:	2958 N/mm <sup>2</sup>
ultimate elongation:	1.12 %
modulus of elasticity:	264 200 N/mm <sup>2</sup>

## 5. CONCLUSIONS

At the Department of Construction Materials and Engineering Geology of Budapest University of Technology and Economics in framework of the En-Core (European Network of Composite Reinforcement) research on fibre reinforced polymers (FRP) is carried out. A gripping device for appropriate tensile loading of FRP strips was developed.

The developed gripping device could be effectively used for tensile tests. Premature failure of high strength carbon FRP strips was avoided. The compressive and shear stresses between the gripping plates were appropriately distributed due to the variable adhesive thickness. This distribution made possible also the gripping of strips without pull-out from the gripping plates.

Using the developed gripping device, tensile strength, modulus of elasticity, ultimate strain, as well as stress-strain behaviour of two high strength carbon FRP strips could be appropriately measured. The measured tensile capacity of the composite strips was higher than indicated by the manufacturer.

The two materials were characterised by slightly different failure modes both explosive in nature. The E170 material failure showed a proper stress distribution in the tested material. The recorded stress-strain diagrams showed linear behaviour of the strips up to failure.

## 6. ACKNOWLEDGEMENTS

The authors gratefully acknowledge the financial support of European Network for Composite Reinforcement EN-CORE Research Training Network FP6 project (Grant: MRTN-CT-2004-512397), as well as the by MAPEI Group's Hungarian Affiliate MAPEI Kft. research support (Budapest Univ. of Technology 34491-003 2007).

## 7. REFERENCES

- Szabó, K. Zs., Balázs, L. Gy. (2008): "Advanced pull-out test for near surface mounted CFRP strips", *Proceedings of Challenges for Civil Construction International Conference*, Porto, accepted for printing.
- Malvar, L. J., Bish, J. (1995): "Grip effects in tensile testing of FRP bars", *Proceedings of Non-metallic (FRP) reinforcement for concrete structures* (ed. Taerwe, L.), pp 108-115.
- ASTM (2000): "Standard test method for tensile properties of polymer matrix composite materials", D 3039/D 3039M.
- Benmokrane, B., Zhang, B., Chennouf, A. (2000): "Tensile properties and pullout behaviour of AFRP and CFRP rods for grouted anchor applications", *Construction and Building Materials*, Vol. 14, pp. 157-170.
- fib* (2001): "Externally bonded FRP reinforcement for RC structures", *fib bulletin* 14, Lausanne
- MAPEI (2003): "Pultruded carbon fibre palate pre-impregnated in epoxy based resin, protected by double plastic film", available at: [http://www.mapei.it/Referenze/Multimedia/1001\\_gb.pdf](http://www.mapei.it/Referenze/Multimedia/1001_gb.pdf)
- CNR (2006): "Guide for the design and construction of externally bonded FRP systems for strengthening existing structures", CNR-DT 200/2004, Rome.

**Prof. György L. Balázs** (1958) PhD, Dr. habil, professor in structural engineering, head of department of Construction Materials and Engineering Geology at the Budapest University of Technology and Economics. His main fields of activities are: experimental and analytical investigations as well as modelling reinforced and prestressed concrete, fiber reinforced concrete (FRC), fiber reinforced polymers (FRP), high performance concrete (HPC), bond and cracking in concrete and durability. He is convenor of *fib* Task Groups on "Serviceability Models" and "fib seminars". In addition to he is a member of several *fib*, ACI, and RILEM Task Groups or Commissions. He is president of the Hungarian Group of *fib*. Member of *fib* Presidium.

**Zsombor K. Szabó** (1981) PhD student at the Department of Construction Materials and Engineering Geology at the Budapest University of Technology and Economics. His main field of interest is bond characteristics of fibre reinforced materials used in the construction industry for structural strengthening. Member of the European Network for Composite Reinforcement as a young stage researcher. Member of the Hungarian Group of *fib*.